



Motor Control and Drive Design Solutions



Microchip's Motor Control and Drive Solutions

Electric motors are estimated to consume around 45% of all the electricity in the world today according to the International Energy Agency (IEA). Electric motors are everywhere—in your washer, dryer, refrigerator, car, fan, pumps, air conditioner, etc.—making our lives easier. Hence, it is important that they run as efficiently as possible, consuming less energy.

Microchip provides products and solutions (hardware and software) to control different motor types, including brushed DC, stepper, brushless DC, permanent magnet synchronous, AC induction and switched reluctance motors. You can shorten your development cycle by using our free motorBench® Development Suite for code generation and tuning of Field Oriented Control (FOC) software. Our scalable motor control development tools facilitate rapid prototyping of low-voltage and high-voltage systems including dual motor control designs.

Microchip's 8-bit PIC® Microcontrollers (MCUs), dsPIC® Digital Signal Controllers (DSCs) and 32-bit PIC32MK and SAM MCU (Arm® Cortex®-M) series devices contain innovative motor control Pulse Width Modulation (PWM) peripherals with complementary waveform generators and dedicated time bases. The high-performance PIC32MK MCUs, Cortex-M4, Cortex-M7 SAM MCUs and dsPIC33 DSCs feature a DSP engine to achieve real-time execution of math intensive algorithms like FOC and variable speed with constant torque. The PIC32MK and SAM MCUs (Cortex-M4F, Cortex-M7) feature a floating point unit (FPU) for floating point math operations. The dsPIC33CH DSCs offer dual cores for increased performance and enable one core to be dedicated for the time-critical motor control function and a second core for system functions and communication.

Microchip's MOSFET Gate Driver family supports different type of motors such as, brushed DC motors, three phase brushless motors and stepper motors. The gate drive products are designed to offer robust protection against short circuits, over current and temperature. Our portfolios of op amps, current sense amplifiers and LDOs, together with gate drive products, complement our MCUs and DSCs and enable you to easily design complete motor control systems, while reducing board space requirements, streamlining the design process and lowering design risk.

Designed for low power, Microchip's FPGA motor control solution suite targets high-performance motor control applications. Suitable applications include multi-axis servo drives, motion control of multiple motor types in robotic arms and motor control in high-reliability applications like avionics actuator control, electric vehicle traction control and medical devices. The FPGA motor control suite supports BLDC (sensorless, hall, encoder, resolver support), stepper (micro-stepping with 2048 steps) and induction motors.

Complete Motor Control Solution

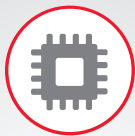

Motor Control Silicon

- Cost-competitive and superior architectures, with single- and dual-core options
- Large scalable family of 8-, 16- and 32-bit MCUs, dsPIC33 DSCs and FPGAs
- High-resolution PWMs down to 250 ps
- Integrated op amps and analog comparators for cost reduction
- Range of hardware features for functional safety compliance
- 3V and 5V options with up to 150°C operations and automotive qualification



Motor Control Algorithms

- ACIM/BLDC/PMSM/IPM
- Brushed DC/stepper
- Sensor/sensorless control
- Field Oriented Control (FOC)
- Power Factor Control (PFC)
- Field weakening
- Wind milling
- Initial Position Detection (IPD)
- Maximum Torque per Ampere (MTPA)
- Stall detection and recovery
- Voltage compensation and torque compensation



Motor Control Ecosystem

- Application notes
- Motor control library with source code
- Reference designs
- Low-cost development boards
- motorBench Development Suite
- Modeling and simulation support
- Motor control algorithm tuning guides
- Real-time debug of motor control parameters
- Worldwide expert support

Brushed DC Motors

Brushed DC (BDC) motors get their name from the “brushes” used for commutation. Brushed DC motors are easy to control because speed and torque are proportional to the applied voltage and current. The rotor is heavy due to windings on the armature; more inertia makes it more difficult to start/stop. The heat generated in the windings of the rotor is difficult to remove. However, due to the simplicity of controlling these motors, brushed DC motors are still used in a wide variety of applications.



Key Characteristics of Brushed DC Motors

- Good controllability: on/off, proportional control
- Linear torque and current curve
- Speed proportionate to voltage applied
- Brush Maintenance required
- Low overloading capability

Typical Applications

- Toys
- Window wipers
- Door locks
- Window lifts
- Antenna retractors
- Power seats
- Hand drills

Brushed DC Motor Application Notes

Algorithm	App Note
Low-Cost Bi-Directional Brushed DC Motor Control Using the PIC16F684	AN893
Brushed DC Motor Fundamentals	AN905
DC Motor Control with Touch Interface and IR Communication	AN2933

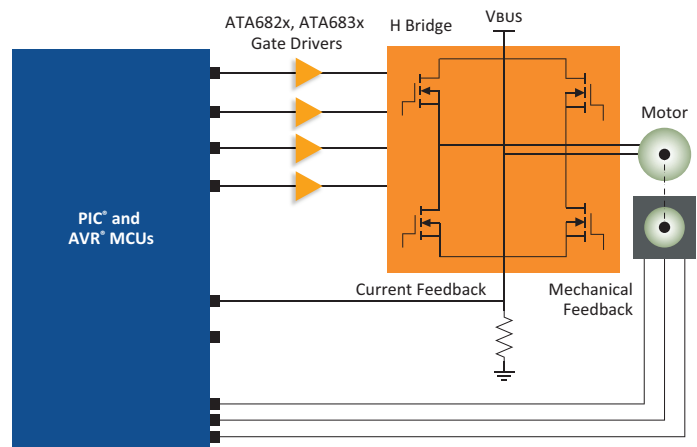

Brushed DC Motor Development Tools

MTS2916A Dual Full-Bridge Brushed DC/Stepper Motor Driver Evaluation Board (ADM00308)

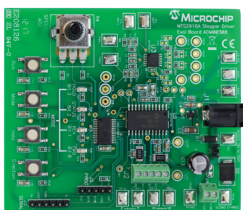

The MTS2916A Dual Full-Bridge Brushed DC/Stepper Motor Driver Evaluation Board demonstrates the capabilities of the MTS2916A to control two brushed DC motors. The board also demonstrates the capabilities of the MTS62C19A, which has the same functionality, but different pin assignments.

Stepper Motors

Do you need exact position control with great holding torque? If so, then a stepper motor is the best solution. While nearly every MCU or DSC from Microchip can drive a stepper motor, Microchip offers a complete line of dual full-bridge drivers designed to drive bipolar stepper motors. These can be easily interfaced to any microcontroller. Microchip's 8-bit PIC MCUs are an excellent solution for traditional stepper motor control. Microchip's dsPIC DSCs, PIC32MK, Arm Cortex-M4F and M7 class devices with DSP capability and advanced motor control peripherals are ideal for applications requiring closed-loop stepper motor control with sub micro-stepping, high-speed rotation and full torque output.

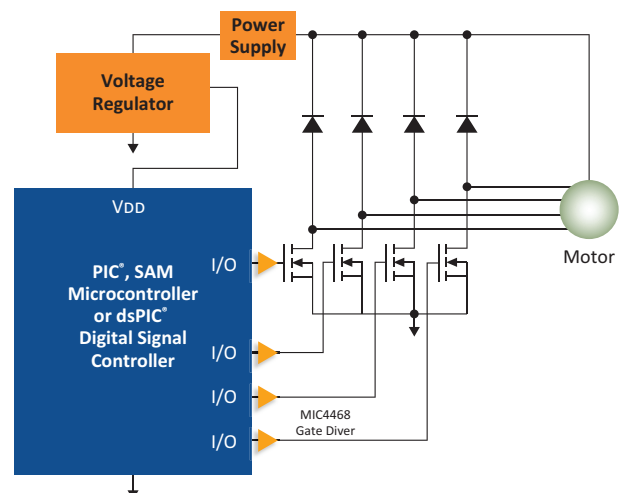
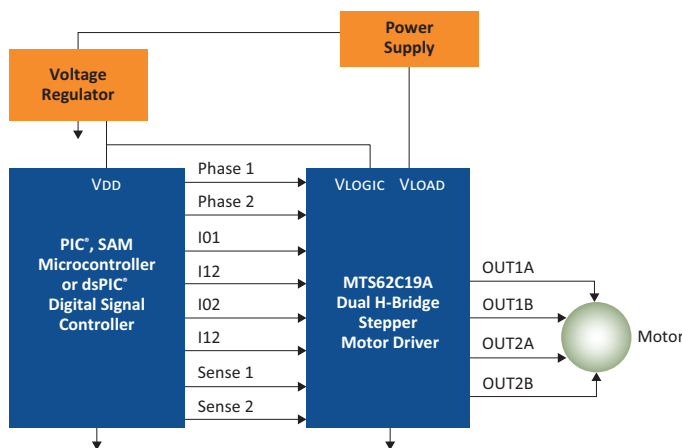

Typical Applications

- Idle speed adjust
- Exhaust gas recirculation
- Duct airflow vanes
- Mirror control
- Telescopes
- Antennas
- Toys

Stepper Motor Development Tools

dsPICDEM™ Motor Control Stepper Motor (MCSM) Development Board (DM330022-1)



This board can control both unipolar and bipolar stepper motors in open- or closed-loop (current control) mode. The hardware is designed to support 8-, 6- or 4-wire stepper motors (bipolar or unipolar). The

associated software can run motors in open- or closed-loop with full or variable micro-stepping. A GUI is provided for controlling step commands, motor parameter input and operation modes. This flexible and cost-effective board supports dsPIC33CK motor control DSCs.

Stepper Motor Application Notes

Algorithm	PIC16 Family	PIC18 Family	AVR® Family	dsPIC® DSC Family
Motor Control Theory	AN907			
Full- and Half-Stepping	AN906, AN2326	–	AN8017	AN1307
Micro-Stepping	AN2326	AN822		AN1307

Stepper Motor (AC300024)

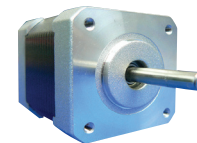

This Leadshine stepper motor can be used with the dsPICDEM MCSM Development Board (DM330022-1). Featuring 8 leads, it can be configured for unipolar or bipolar operation and has a step angle of 1.8°.

MTS2916A Stepper Motor Driver Evaluation Board (ADM00308)

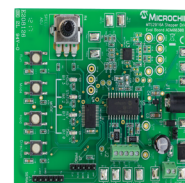

This evaluation board includes push-button switches and a variable-speed input potentiometer to demonstrate the MTS2916A controlling a stepper motor in full-step, half-step, modified half-step and micro-stepping modes.

Brushless DC Motor Control

BLDC Motors

Looking for a high reliability, high efficiency and high power-to-size ratio motor? The obvious solution is a Brushless DC (BLDC) motor. It shares many of the same torque and speed characteristics with the brushed DC motors, but eliminates the brushes. Technically, it is a Permanent Magnet Synchronous Motor (PMSM), but the motor is driven with a simple 6-step square wave form or trapezoidal commutation. In some cases, the stator windings are constructed to match the trapezoidal commutation.

The simpler commutation method allows a wide range of Microchip products to be used for control, from 8-bit PIC16 MCUs, MTD650X dedicated BLDC driver chips, advanced dsPIC DSCs, to PIC32 and SAM MCUs in sophisticated applications. The device best suited to your application depends on the performance, cost and efficiency you are trying to achieve in your design. Our comprehensive ecosystem around BLDC motor control will allow you to get started with your application quickly.

Typical Applications

- Anti-lock braking systems
- Throttle control
- Fuel pumps
- Oil pumps
- Cordless hand drills
- Electric lawn mowers
- Electric bicycles

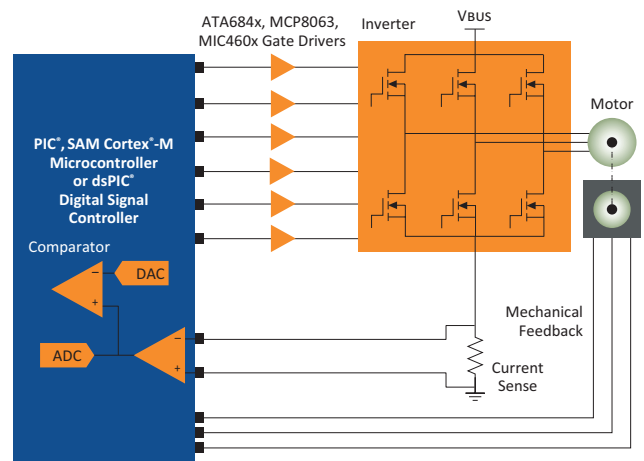

BLDC Application Notes and Tuning Guides

Algorithm	PIC16 Family	PIC18 Family	AVR® Family	dsPIC® DSC Family	PIC32 or SAM MCU Family
Motor Control Theory			AN885		
Sensored 6-Step Commutation with Hall Sensors	-	AN899	AN2522, AVR194, AN7672	AN957	42711A
Sensored Commutation with Hall Sensors for Single Phase BLDC	AN1779, AN2049				
Sensored Sinusoidal	AN2557	-	AN8010, AN8030	AN1017	
Sensorless BEMF	AN1175, AN1305, AN857	AN970	AN8012, AN7658, AN_8306	AN901, AN992	
Sensorless Filtered BEMF with Majority Detect	-	-		AN1160	
Tuning Guide: Sensorless BLDC Control with Back-EMF Filtering Using a Majority Function	-	-		AN1160	

Permanent Magnet Synchronous Motors

Permanent Magnet Synchronous Motors are brushless and have very high reliability and efficiency. Due to their permanent magnet rotor, they also have higher torque with a smaller frame size and no rotor current, all of which are advantageous over AC induction motors. With a high power-to-size ratio, PMSMs can help you make your design smaller without the loss of torque. PMSMs need to be commutated like BLDC motors, but due to the construction of the stator windings, the waveforms need to be sinusoidal for good performance. This requires more complicated control algorithms and therefore higher performance controllers like Microchip's dsPIC DSCs and PIC32MK or SAM MCUs offer ideal solutions. Microchip offers a comprehensive ecosystem to help you develop advanced PMSM control solutions like sensorless Field-Oriented Control (FOC). Microchip supports solutions for Surface Mounted Permanent Magnet Synchronous Motor (SPMSM) and Interior Permanent Magnet Synchronous Motor (IPMSM).

Typical Applications

- Air conditioner and refrigerator compressors
- Direct-drive washing machines
- Automotive electrical power steering
- Machining tools
- Traction control
- Industrial sewing machines

FOC Algorithm Support

Motor Control Library for dsPIC33

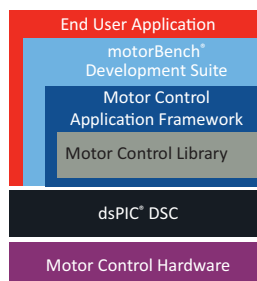

The Motor Control Library contains FOC function blocks that are optimized for the dsPIC33 DSC families. The library functions are designed to be used within any application framework for realizing an efficient and flexible way of implementing a motor control application. The Motor Control Library is available in standalone C code and assembly code versions. Visit www.microchip.com/motor-control-library to learn more and download the library.

The Motor Control Library is widely used in our application notes and is integrated into our Motor Control Application Framework (MCAF) and motorBench Development Suite.

Advanced FOC Features

Microchip provides source code and implementation examples for advanced FOC features to solve application related challenges and improve system reliability. Supported algorithms include:

- Field weakening
- Wind milling
- Initial Position Detection (IPD)
- Stall detection and recovery
- Maximum Torque Per Ampere (MTPA)
- Soft stop
- Voltage compensation and torque compensation
- DC bus compensation
- Over modulation
- Angle Tracking Phase Locked Loop (AT-PLL) estimator

Visit www.microchip.com/Advanced-FOC to learn more.

motorBench Development Suite

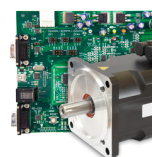

The motorBench Development Suite is a GUI-based software development tool for Field Oriented Control (FOC), performing accurate measurement of critical motor parameters, automatic tuning of feedback control gains and generating source code for an MPLAB® X IDE project. It utilizes the Motor Control Application Framework (MCAF) and seamlessly integrates with MPLAB X IDE as a plug-in to MPLAB Code Configurator (MCC).

Using the motorBench Development Suite, you can spin your motor easily and get your embedded design to market faster by reducing the time needed to tune the FOC algorithm for new motors.

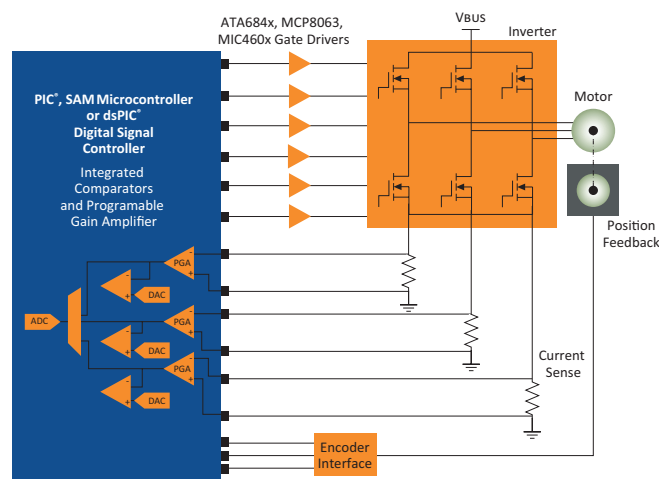

Permanent Magnet Synchronous Motors

motorBench Development Suite Works With:

- dsPICDEM MCLV-2 Development Board (DM330021-2) for low-voltage motors (up to 48 Volts and 10 Amps)
- dsPICDEM MCHV-3 Development Board (DM330023-3) for high-voltage motors (85–256 Volts and 15 Amps),
- dsPIC33EP256MC506 External OpAmp Motor Control PIM (MA330031-2) (256 Volts and up to 15 Amps)

To download and spin your motor in no time, visit www.microchip.com/motorBench.

Motor Control Application Framework (MCAF)

MCAF is Microchip's next-generation application framework for motor control on dsPIC DSCs. MCAF is integrated into the motorBench Development Suite and gets auto generated into the desired MPLAB X IDE project, including a hardware abstraction layer. MCAF supports a variety of FOC algorithm features like overmodulation and DC link voltage compensation. MCAF has a modular architecture to ease inclusion into your application and enables rapid development of FOC applications.

FOC Simulation and Code Generation

Motor Control Library Blockset for MATLAB® and Simulink®

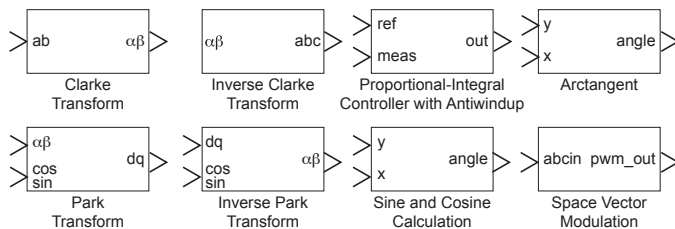

The Motor Control Library Blockset contains a number of basic Simulink blocks that can be used to jump start model-based design of motor control applications using the dsPIC33 DSC, PIC32MK and SAM E70 MCU families. These blocks include reference frame transforms, proportional-integral controller and trigonometric functions, all of which can be used with the

Embedded Coder® to generate efficient code by utilizing the Microchip Motor Control Library.

Visit www.microchip.com/simplified to learn more.

MPLAB Device Blocks for MATLAB and Simulink

The MPLAB Device Blocks are a suite of Simulink Library and scripts for MATLAB that configures the microcontroller and its peripherals. Developed by Microchip, these device blocks integrate seamlessly within the MATLAB and Simulink environment. The device blocks enable design of complex algorithms using tools such as Simulink, instead of hand-coding. You can go back and forth from high-level simulation to real hardware test efficiently using the device blocks and remove the burden of low-level programming. The device block set enables complete model-based control using dsPIC DSC and PIC32MK MCUs. Visit www.microchip.com/simplified to learn more.

PMSM Motor Model for Simulink



PMSM Motor Model Block set is a set of components to be used with the Simulink simulation tool. These blocks allow engineers to model a closed loop control system for a PMSM using our range of MCUs and dsPIC DSCs.

This PMSM Model assists in the development, testing and understanding of motor control systems. You can benefit from this free simulation block to confirm the behavior of real systems and explore the system behavior under conditions that are impossible or cumbersome to test in reality.

Visit www.microchip.com/simplified to learn more.

X2C Motor Control Blockset for Scilab and Xcos

The Scilab and Xcos suite is a free and open source tool chain for simulation, data analysis and algorithm development in real time control applications. X2C Motor Control Blockset enables control algorithm simulation and code generation for dsPIC DSCs and PIC32 MCUs. Microchip also provides FOC examples to use Scilab and Xcos for motor control development. Visit www.microchip.com/X2C to learn more.

PMSM Application Notes and Tuning Guides

Algorithm	dsPIC® DSC Family	PIC32 or SAM MCU Family
Sensored Sinusoidal	AN1017	AN2757
Sensorless Dual-Shunt FOC with Reduced Order Luenberger Observer		AN2590
Sensorless Dual-Shunt FOC with SMO Estimator and Field Weakening	AN1078	
Sensorless Single-Shunt FOC with SMO Estimator and Field Weakening	AN1299	
Sensorless Dual-Shunt FOC with SMO and PFC	AN1208	
Sensorless Dual-Shunt FOC with PLL Estimator and Field Weakening	AN1292	AN2520
Sensorless Dual-Shunt FOC with PLL Estimator and PFC		AN2584
Tuning Guide: Sensorless Single-Shunt FOC with SMO Estimator PMSM	AN1299 Tuning Guide	

BLDC and PMSM Development Tools

dsPICDEM MCLV-2 Development Board (DM330021-2)

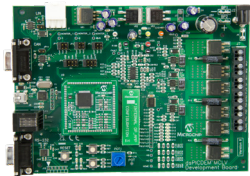

This low-voltage development board provides a cost-effective method of evaluating and developing sensed or sensorless Brushless DC (BLDC) motor and Permanent Magnet Synchronous

Motor (PMSM) control applications. The board supports dsPIC33 DSCs and 32-bit PIC32 and SAM MCUs. Each family is supported by a Plug-In Module (PIM) which connects to the MCLV-2 Development Board. It also supports the use of on-chip op amps found on certain dsPIC DSCs and PIC32MK MCUs or the external op amps found on the MCLV-2 board. This board comes with dsPIC33EP256MC506 Internal Op Amp PIM (MA330031) and includes support for a wide range of dsPIC DSC PIMs. For PIC32MK support, the PIC32MK1024 PIM (MA320024) is available. SAM devices supported include ATSAMD21 (MA320206), ATSAME54 (ma320207) and the SAM E70 (MA320203). The board is capable of controlling motors rated up to 48V and 10A, with multiple communication channels such as USB, CAN, LIN and RS-232.

dsPIC33CK Low Voltage Motor Control (LVMC) Development Board (DM330031)

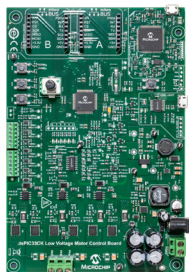

The dsPIC33CK Low Voltage Motor Control (LVMC) Development Board is a cost-effective rapid development platform for Brushless DC (BLDC), Permanent Magnet Synchronous Motor (PMSM) and Internal Permanent Magnet (IPM) motor control applications. The LVMC development board operates from 12 to 48 Volts and up to 10 Amps of continuous current or up to 20

Amps with a fan or heatsink. The board supports application development for sensed six-step trapezoidal or sinusoidal control with hall sensors, sensorless BEMF measuring phase voltages, or Field Oriented Control (FOC) with single, dual or triple-shunt resistor current sensing circuits. This flexible architecture allows you to evaluate various design techniques that suit your application requirements, balancing the cost and performance.

dsPICDEM MCHV-2/-3 Development Boards (DM330023-2, DM330023-3)



This high-voltage development board aids you in the rapid evaluation and development of a wide variety of motor control applications for dsPIC DSCs, PIC32MK and SAM devices. The MCHV uses an 100-pin

PIM interface to support evaluation of Microchip's MCU and DSC families. This development system is targeted to control BLDC motors, PMSMs and ACIMs in sensor or sensorless operation. The rated continuous output current from the inverter is 6.5A RMS. This allows up to approximately 2 kVA output when running from a 208V to 230V single-phase input voltage. The MCHV-3 has PFC with current feedback circuitry and zero-crossing detection interface to support evaluation of Microchip's MCU and DSC families. The board comes with dsPIC33EP256MC506 Internal Op Amp PIM (MA330031).

SAM MCU 24V BLDC Motor Control Kit (ATSAMD21BLDC24V-STK)



The kit contains an MCU control board featuring the ATSAMD21 microcontroller and embedded debugger and a driver board with drivers supporting motors operating up to 24V DC. The PCB is mounted

on a chassis with a motor and can be directly connected to a PC running Atmel Studio and Atmel START for immediate development and debug of motor control applications.

Low-Voltage Motor Control Development Bundle (Signal Board and Drive Board) (DV330100)

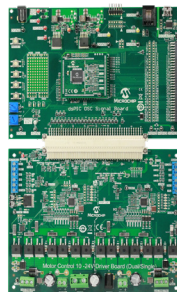

This bundle provides the capability to evaluate and develop dual/single motor control to drive two BLDC motors or two PMSMs, or one of each type of motor. The dsPIC DSC Signal Board supports both 3.3V and 5V devices, human interface features and isolated USB and UART communication interface. The Motor Control 10–24V Driver Board supports output up to 10A RMS on each phase.

AC Induction Motors

The AC Induction Motor (ACIM) is the workhorse of the motor world. It is the most common motor type, used in everything from consumer products to heavy industry. Its simple design with no brushes makes it highly reliable and allows it to be manufactured at a low cost. However, it is less efficient than other motors like PMSMs, which is partially related to the heat generation in the rotor windings.

The open-loop Voltage/Frequency (V/F) drive technique is traditionally used to control ACIMs and can be implemented on a simple 8-bit PIC MCU. For applications that need higher efficiency, an advanced control solution like FOC can be applied. This requires a high-performance dsPIC DSC, PIC32 or SAM MCU.

Typical Applications

- Air conditioner and refrigerator compressors
- Home appliances
- Pumps
- Blowers
- Automation/industrial applications
- Power tools

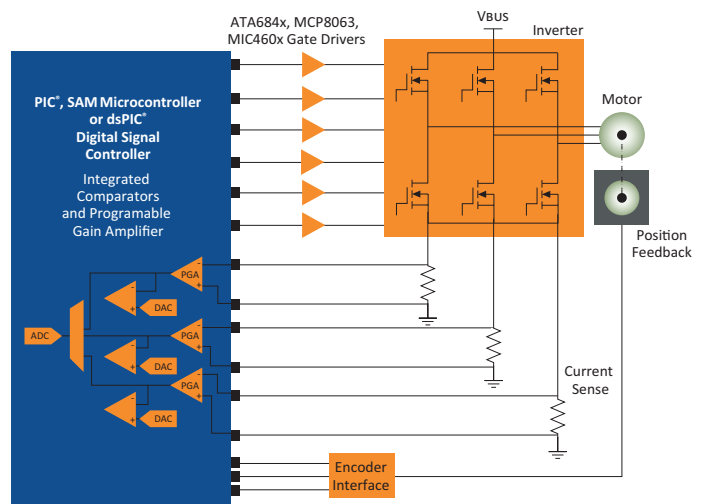

AC Induction Motor Application Notes

Algorithm	PIC16 Family	PIC18 Family	AVR® Family	dsPIC® DSC Family
Motor Control Theory			AN887	
Open-Loop V/F	AN889, AN955, AN967, AN1660	AN900, AN843	AN7545	AN984
Closed-Loop Vector Control	–	–	AN7546	AN908
Sensorless Dual-Shunt FOC with PLL Estimator	–	–		AN1162
Sensorless Dual-Shunt FOC with PLL Estimator and Field Weakening	–	–		AN1206

AC Induction Motor Development Tools

dsPICDEM MCHV-2/-3 Development Boards (DM330023-2, DM330023-3)



This high-voltage system is intended to aid you in the rapid evaluation and development of motor control applications for dsPIC DSCs, PIC32MK, and SAM devices. The MCHV kit uses a PIM interface to support evaluation of

Microchip's MCU and DSC families. This development system is targeted to control BLDC motors, PMSMs and ACIMs in sensor or sensorless operation. This allows up to approximately 2 kVA output when running from a 208V to 230V single-phase input voltage. The MCHV-3 has PFC with current

feedback circuitry and zero-crossing detection interface to support evaluation of Microchip's MCU and DSC families. The board comes with dsPIC33EP256MC506 Internal Op Amp PIM (MA330031).

AC Induction Motor (AC300023)



This compact 3-phase AC Induction Motor has been certified for use with dsPIC33 ACIM motor control application notes in conjunction with the dsPICDEM MCHV-2/-3 Development Boards (DM330023-2, DM330023-3).

FPGA-Based Motor Control

It is common to find multiple motors employed in a single application with all the motors being synchronously operated or dependent on each other to perform a complex task. Precise control of motor speed and torque delivered is a critical requirement for many of these multi-axis motor control applications. The reliability of motors/controllers is also essential to ensure a safe operating environment. Microchip's low-power SmartFusion² SoC-FPGA-based deterministic motor control solution is designed specially to meet the challenging requirements of precise control, performance, scalability, reliability and safety in an easy-to-use environment. Microchip offers a modular Intellectual Property (IP) portfolio to quickly implement motor control applications on FPGAs. The IP portfolio includes motor control function blocks for FOC, as well as position and speed estimator PI controllers. Microchip supports FPGA-based motor control with development tools, reference designs, kits and software.

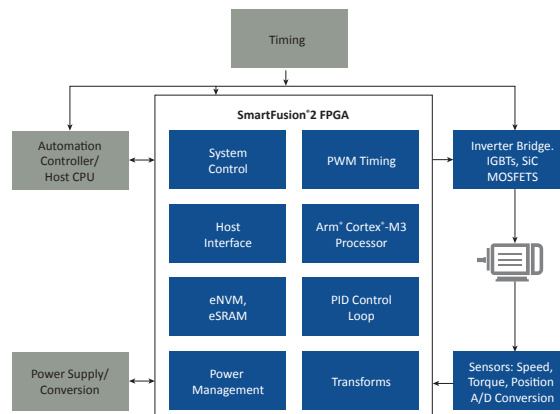

Typical Applications

- Servo drives
- Industrial drones
- Linear drive machine tools
- Surveillance cameras
- Medical robots
- Actuators in aviation
- Robots
- Hybrid/electric vehicles

FPGA Motor Control Solution Ecosystem

SmartFusion2 Dual-Axis Motor Control Starter Kit (SF2-MC-STARTER-KIT)

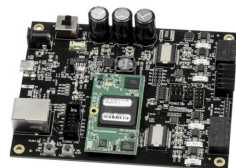

This starter kit gives you a great starting point for evaluating time-saving, proven motor control reference designs. It is supplied with hardware and software IP blocks and a fully integrated solution along with a powerful, easy-to-use GUI that enables quick prototyping. The kit also supports various communication interfaces including Ethernet, CAN, RS485, USB and others. Motor performance is tested for speeds exceeding 100,000 RPM for sensorless FOC. The low latency of 1 μ s for FOC loop from ADC measurement to PWM generation allows switching frequencies up to 500 kHz.

The kit also has advanced safety features like “rotor slip and overload detection” and “overcurrent protection”. The SF2-MC-STARTER-KIT supports DC input voltages from 12V to 48V and max AC current of 8A per phase (Motor-1 up to 3 phases, Motor-2 up to 4 phases). The solution has control designs which are implemented for motor control algorithms mentioned in the table. The position control algorithm of stepper motor supports up to 2048 micro-steps.

Reference Design Features

- Motor control algorithms implemented in FPGA fabric
- Scalability to a multi-axis motor drive design
- Design flexibility with modular IP suite
- Deterministic, high precision, low power, reliable and secure
- Robust sensorless solution—supports 100K RPM or more
- Integration of system functions to lower Total Cost of Ownership (TCO)
- Low latency of 1 μ s for FOC loop

Motor Control Software and GUI

The SmartFusion2 Motor Control GUI allows for the dynamic tuning of parameters, such as reference speed, Kp/Ki gains of PI controllers and viewing internal signals for debugging. Visit www.microchip.com/fpga-motor-control to learn more.

Motor	Algorithm
PMSM/ BLDC	FOC sensorless
	FOC with HALL
	FOC with encoder
	FOC with Resolver
Stepper	Microstepping



FPGA-Based Motor Control

Motor Control IP Suite (MCSOLCores-RM)

FOC Transformation IPs	Rate Limiter
PI Controller	Position and Speed Estimator
Space Vector Modulation	Encoder, HALL, Resolver I/F
Core 3 Phase PWM	Stepper Angle Generator

Microchip offers a modular comprehensive IP portfolio and solution for multi-axis deterministic motor control applications. The rich library of IP provides for quick and easy implementation, optimized to leverage FPGA advantages. The IPs are available as encrypted design projects (Libero® SoC), VHDL and Verilog code for FPGA. The Motor Control IP Suite is fully tested and optimized to work with the SmartFusion2 Dual-Axis Motor Control Starter Kit.

FPGA-Based Motor Control Product Brief, IP User Guides and White Papers

Document	Product Brief/ White Paper
SoC Deterministic Motor Control Dual Axis Product Brief	Product Brief
Low-Power, Secure and Deterministic Multi-Axis 100+ kRPM Motor Control Solutions	WP0201
Designing With Microchip's SoC FPGAs for Industrial and Motor Control Solutions	WP0189
Motor Control Design Using SmartFusion2 and IGLOO®2 Devices	AC445

Document	IP User Guide
Sequence Controller User Guide	UG0678
Hall Interface User Guide	UG0690
Encoder Interface User Guide	UG0659
Open-loop Manager User Guide	UG0658
ADC Scaling v4.2 User Guide	UG0657
PWM Scaling User Guide	UG0656
Speed ID IQ PI Controller IP User Guide	UG0612
Stepper Theta Generation IP User Guide	UG0609
Median Filter v4.1 User Guide	UG0845

Document	IP User Guide
Rate Limiter IP User Guide	UG0595
BLDC Estimator v4.2 User Guide	UG0608
FOC Transformations User Guide	UG0607
Three-phase PWM User Guide	UG0362
Space Vector Modulation IP User Guide	UG0468
Sinc3 Filter v4.1 User Guide	UG0733
Resolver Interface v4.2 User Guide	UG0735
T-Format Interface User Guide	UG0812

Visit www.microchip.com/fpga-motor-control to learn more.

Recommended FPGAs for Complex Motor Control

	Features	M2S005	M2S010	M2S025	M2S050	M2S060	M2S090	M2S150	
Logic/ DSP	Maximum Logic Elements (4LUT + DFF) *	6,060	12,084	27,696	56,340	56,520	86,316	146,124	
	Math Blocks (18x18)	11	22	34	72	72	84	240	
Security	AES256, SHA256, RNG	1 each				1 each			
	ECC, PUF	-				1 each			
MSS	Cortex-M3 + Instruction cache	Yes							
	eNVM (K Bytes)	128	256				512		
	eSRAM (K Bytes)	64							
	eSRAM (K Bytes) Non SECDED	80							
	CAN, 10/100/1000 Ethernet, HS USB	1 each							
	Multi-Mode UART, SPI, I2C, Timer	2 each							
	Total RAM (K bits)	191	400	592	1314	1314	2074	4488	
High Speed	DDR Controllers (Count x Width)	1x18		2x36		1x18	1x18	2x36	
	SERDES Lanes	0	4	8		4	4	16	
	PCIe End Points	0	1		2			4	
	Total User I/O	209	233	267	377	387	425	574	
Grades	Temperature Grade	C,I,T2	C,I,M,T2	C,I,M,T2	C,I,M,T2	C,I,M,T2	C,I,M,T2	C,I,M	

* Total logic may vary based on utilization of DSP and memories in the design. Please see SmartFusion2 Fabric UG for details

* Automotive grade is available only in VF256, VF400, FG484, FG676 and TQ144 packages

Functional Safety

Microchip offers products and solutions that enable system-level functional safety compliance. This means that they have integrated features, qualified test libraries, safety manuals and FMEDA reports, depending on the standard and the level of safety they support. All these items make it easier to develop applications that conform to the functional safety standards, and thereby reduce the work and cost of the final product compliance.

	AVR®/PIC® MCUs	dsPIC® DSCs	PIC32/SAM MCUs
Class B library (IEC 60730)	Yes	Yes	Yes
AutoSAR/MCAL	–	Yes	Yes
Functional Safety Application Notes	Yes	Yes	Yes
Safety Manual	Available upon request	Available upon request	-
FMEDA Reports	–	Available upon request	–
Safety Qualified Compiler (Qualified for ISO 26262 up to ASIL D)	XC8 compiler	XC16 compiler	IAR Embedded Workbench for XC32 compiler, Arm®
Code Coverage Tools	MPLAB® X IDE Code Coverage Tool SW006026-COV or from 3rd party providers such as LDRA		

Microchip's MCUs and DSCs include integrated safety features to facilitate ISO 26262 compliance for automotive vehicles, IEC 60703 compliance for household goods (Class B safety compliance) and the IEC 61508 compliance for electrical and electronic equipment. For more information on the functional safety features and resources, visit www.microchip.com/functionalsafety.

Enhanced Robustness with 3V and 5V Operation

Microchip's dsPIC DSCs, PIC16, PIC18 and SAM Cortex-M0+ MCU portfolios include families that operate at 3V and 5V for increased noise immunity and robustness. Devices with 5V operation provide more dynamic range for signals and improved sensitivity. The 5V devices include additional features to ensure robust operation such as:

- Backup system oscillator
- Windowed Watchdog Timer (WWDT)
- PWM with fault detection
- Support for temperatures up to 150°C
- AEC-Q100 Grade 0 qualification for automotive applications

Extreme Temperatures and AEC-Q100 Qualification

A variety of devices are also rated for operation up to 125°C or 150°C ambient temperature for the most extreme automotive and industrial applications, including AEC-Q100 Grade 0 qualification. Some target applications require operation in extreme environmental conditions. Microchip's DSCs, MCUs and gate drivers have options for standard (85°C), extended (125°C) and even high temperature (up to 150°C) for automotive applications. The dsPIC33 DSC, 8-bit PIC MCUs and gate drivers support AEC-Q100 Grade 0 qualification for 150°C support, which is especially helpful for “under the hood” systems. PIC32 and SAM Cortex-M MCU families have devices rated up to 125°C of operation and AEC-Q100 Grade 1 rating for automotive applications.

Temperature Ranges	Range	Part Number Suffix
Standard	–40 to 85°C	I
Extended	–40 to 125°C	E
High	–40 to 150°C	H

For more information, visit www.microchip.com/hightemp.

Recommended Microcontrollers for Brushed DC Motor Control

Device	Pins	Flash (KB)	SRAM (Bytes)	EE (Bytes)	HEF	ADC	Comparator	CCP/ECCP	PWM (8-/10-bit)	CWG/COG	DAC (5-/8-bit)	Timer (8-/12-/16-bit)	CLC	SMT	NCO	PPS	EUSART/AUSART	MSSP	SPI/I ² C
PIC16F15313	8	3.5	256	-	✓	5 ch, 10-bit	2	1/0	0/4	1/0	1/0	1/0/2	4	-	1	✓	1/0	1	-
PIC16F15323	14	3.5	256	-	✓	11 ch, 10-bit	2	2/0	0/4	1/0	1/0	1/0/2	4	-	1	✓	1/0	1	-
PIC16F1613	14	3.5	256	-	✓	8 ch, 10-bit	2	2/0	-	1/0	0/1	4/0/1	-	2	-	-	-	-	-
PIC16F1509	20	14	512	-	✓	12 ch, 10-bit	2	-	0/4	1/0	-	2/0/1	4	-	1	-	1/0	1	-
ATtiny417	24	4	256	128	-	12 ch, 10-bit	1	3/0	4/0	-	0/1	0/1/2	1	-	-	✓	1/0	-	1/1
ATtiny817	24	8	256	128	-	12 ch, 10-bit	1	3/0	4/0	-	0/1	0/1/2	1	-	-	✓	1/0	-	1/1
ATSAMD20	14	16	2048	-	-	14-ch 12-bit	2	8/8	12x 16-bit	-	1x 12-bit	0/5/2	-	-	-	✓	6	-	6

Recommended Drivers for Brushed DC Motors

Part #	Input Voltage Range (V)	Internal/ External FETs	Output Current (mA)	Control Scheme	Protections	Temperature Operating Range (°C)	Features	Packages
ATA6826C	7 to 40	Internal	1000	SPI	Short Circuit, Overtemperature, Power Supply Fail	-40 to +125	3 half bridge outputs, No shoot-through, Very low quiescent current <2 µA	SO14
ATA6831C	7 to 40	Internal	1000	SPI	Short Circuit, Overtemperature, Power Supply Fail	-40 to +125	3 half bridge outputs, No shoot-through, Very low quiescent current <2 µA, PWM input	18-pin 4 x 4 QFN
ATA6832C	7 to 40	Internal	1000	SPI	Short Circuit, Overtemperature, Power Supply Fail	-40 to +150	3 half bridge outputs, No shoot-through, Very low quiescent current <2 µA, PWM input	18-pin 4 x 4 QFN
ATA6836C	7 to 40	Internal	650	SPI	Short Circuit, Overtemperature, Power Supply Fail	-40 to +125	6 half bridge outputs, No shoot-through, Very low quiescent current <2 µA	SO28
ATA6838C	7 to 40	Internal	950	SPI	Short Circuit, Overtemperature, Power Supply Fail	-40 to +125	6 half bridge outputs, No shoot-through, Very low quiescent current <2 µA	24-pin 5 x 5 QFN
ATA6823C	7 to 20	External	100	PWM, DIR	Short Circuit, Overtemperature, Over/ Under Voltage, Chargepump Fail	-40 to +125	Dead time adjust, Charge pump supply for external battery reverse protection NMOS, LDO 3V3/5V, Window Watchdog, LIN TRX, Sleep mode <45µA	32-pin 7 x 7 QFN
ATA6824C	7 to 20	External	100	PWM, DIR	Short Circuit, Overtemperature, Over/ Under Voltage, Chargepump Fail	-40 to +150	Dead time adjust, Charge pump supply for external battery reverse protection NMOS, LDO 3V3/5V, Window Watchdog, HV interface	32-pin 7 x 7 TQFP

Recommended Microcontrollers for Entry-level Stepper Motor Control

Device	Pins	Flash (KB)	SRAM (Bytes)	EE (Bytes)	HEF	ADC	Comparator	CCP/ECCP	PWM (8-/10-bit)	CWG/COG	DAC (5-/8-bit)	Timer (8-/12-/16-bit)	CLC	SMT	Angular Timer	NCO	Math Accelerator	PPS	EUSART/AUSART	MSSP	SPI/I ² C
PIC16F15323	14	3.5	256	-	✓	11 ch, 10-bit	2	2/0	0/4	1/0	1/0	1/0/2	4	-	-	1	-	✓	1/0	1	-
PIC16F15355	28	14	1K	-	✓	24 ch, 10-bit	2	2/0	0/4	1/0	1/0	1/0/2	4	-	-	1	-	✓	2/0	-	2/2
PIC16F18324	14	14	512	256	-	11 ch, 10-bit	2	4	0/2	2/0	1/0	2/0/1	4	-	-	1	-	✓	1/0	1	2/2
PIC16F1509	20	14	512	-	✓	12 ch, 10-bit	2	-	0/4	1/0	-	2/0/1	4	-	-	1	-	-	1/0	1	-
PIC16F1618	20	7	512	-	✓	12 ch, 10-bit	2	2/0	0/2	1/0	0/1	4/0/1	2	1	1	-	1	✓	1/0	-	1
ATtiny817	24	8	256	128	-	12 ch, 10-bit	1	3/0	4/0	-	0/1	0/1/2	1	-	-	-	-	✓	1/0	-	1/1
ATtiny1617	24	16	2048	256	-	24 ch, 10-bit	3	3/0	4/0	-	0/3	0/1/3	1	-	-	-	-	✓	1/0	-	1/1
ATSAMD20	14	16	2048	-	-	14-ch 12-bit	2	8/8	12x 16-bit	-	1x 12-bit	0/5/2	-	-	-	-	-	✓	6/0	-	6/6

Recommended High-Performance Controllers for Advanced Stepper Motor Control

Device Family	Core	Pins	Flash (KB)	RAM (KB)	DMA # Ch	Timer 16-bit	Input Capture, Output Compare, Standard PWM	Motor Control (PWM Channels)	QEI	ADC	Analog Comparators	Op Amps	UART	SPI	I ² C	PMP	RTCC	CAN	USB 2.0	Package	Temperature Range
dsPIC33EPxxxGM3x/ dsPIC33EPxxxGM6x/ dsPIC33EPxxxGM7x	dsPIC33E	44-100	128-512	16-48	4	9	8-IC, 8-OC	12	2	2 ADC, 18-49 ch	1	4 ⁽¹⁾	4	3	2	0/1	0/1	0/2	-	QFN, TQFP, TFBGA	I, E, H
dsPIC33CKxxMC10x	dsPIC33C	28 - 48	32 - 64	8	4	1	4 -CCP	8	1	1 ADC, 11-15 ch	1	3	3	2	1	-	-	-	-	UQFN, SSOP, TQFP	I, E, H
dsPIC33CKxxMP10x/ dsPIC33CKxxxMP20x/ dsPIC33CKxxxMP50x	dsPIC33C	28-80	32-256	8-24	4	1	5/9- CCP	8/16	2	1 ADC, 12-24 ch	3	3	3	3	3	0/1	-	0/1 ⁽²⁾	-	SSOP, UQFN, TQFP	I, E, H
dsPIC33CHxxxMP20x/ dsPIC33CHxxxMP50x	Dual Core dsPIC33C	28-80	64 -512	20-48	8	2	12- CCP	24	2	4 ADC, 12-18 ch	4	3	3	3	3	-	-	0/1/2 ⁽²⁾	-	SSOP, UQFN, TQFP	I, E, H
PIC32MKxxxxMCJxxx	MIPS32® microAptiv™	48-64	256-512	64	10	9	9-OC 9-IC	18	3	7 ADC, 18-30 ch	5	4	2	2	2	-	1	1	-	UQFN, VQFN, TQFP	I, E
PIC32MKxxxxMCMxxx	MIPS32 microAptiv	64-10	512-1024	128-256	21	9	16-OC 16-IC	24	6	7 ADC, 26-42 ch	5	4	6	6	4	Yes	1	4	2	VQFN, TQFP	I, E
PIC32MKxxxxMCFxxx	MIPS32 microAptiv	64-100	512-1024	128-256	21	14	16-IC, 16-OC	24	6	7 ADC, 26-42 ch	5	4	6	6	Yes	Yes	1	4	1	VQFN, TQFP	I, E
ATSAMC20xxx/ ATSAMC21xxx	CM0+	32-100	32-256	4-32	6	8 - TC		14	-	2 ADC, 20 ch	4	-	4/8		-	1	0/2 ⁽²⁾	-	TQFP, VQFN, WLCSP	I, E	
ATSAMD20xxx/ ATSAMD21xxx	CM0+	32-64	16-256	2-32	-	5 - TC		0/22	-	1 ADC, 20 ch	2	-	6		-	1	-	0/1	QFN, TQFP, UFBGA, WLCSP	I, E	
ATSAMD5xxxx/ ATSAME5xxxx	CM4F	64-128	256-1024	128-256	32	8 - TC		23	1	2 ADC, 32 ch	2	-	8		-	1	0/2 ⁽²⁾	1	QFN, TQFP, TFBGA, WLCSP	I, E	
ATSAM7xxxx/ ATSAME7xxxx	CM7	64-144	512-2048	256-384	24	12 - TC		16	4	2 ADC, 24 ch	1	-	5	3	5	-	1	2 ⁽²⁾	1	QFN, LQFP, LFBGA, TFBGA, UFBGA, VFBGA	I, E

Note 1: Op amps can be configured as comparators. 2: Supports both CAN 2.0 and CAN FD 3: I = Industrial Temperature Range (-40°C to +85°C), E = Extended Temperature Range (-40°C to +125°C), H = High Temperature Range (-40°C to +150°C). 4: IC = Input Capture module, OC = Output Compare PWM module, CCP = Capture Compare PWM module, TC = Timer Counters module
Check www.microchip.com for availability

Recommended Drivers for One Bipolar Stepper Motor or Two DC Motors

Part #	Input Voltage Range (V)	Internal/ External FETs	Output Current (mA)	Control Scheme	Protections	Temperature Operating Range (°C)	Features	Packages
MTS62C19A	10.0 to 40.0	Internal	750	Direct PWM Input, Current Limit Control, Microstepping	Overtemperature, Under Voltage	-40 to +105	Dual Full-Bridge Motor Driver for Stepper Motors, Pin compatible with Allegro 6219	24-pin SOIC
MTS2916A	10.0 to 40.0	Internal	750	Direct PWM Input, Current Limit Control, Microstepping	Overtemperature, Under Voltage	-40 to +105	Dual Full-Bridge Motor Driver for Stepper Motors, Pin compatible with Allegro 2916	24-pin SOIC

Recommended Microcontrollers for Entry-level Brushless DC Motor Control

Device	Pins	Flash (KB)	SRAM (Bytes)	EE (Bytes)	HEF	ADC	Comparator	CCP/ECCP	PWM (8-/10-bit)	CWG/COG	DAC (5-/8-bit)	Timer (8-/12-/16-bit)	CLC	SMT	NCO	PPS	Op Amp	EUSART/AUSART	MSSP	SPI/I ² C
PIC16F15323	14	3.5	256	-	✓	11 ch, 10-bit	2	2/0	0/4	1/0	1/0	1/0/2	4	-	1	✓	-	1/0	1	-
PIC16F15355	28	14	1K	-	✓	24 ch, 10-bit	2	2/0	0/4	1/0	1/0	1/0/2	4	-	1	✓	-	2/0	-	2/2
PIC16F1509	20	14	512	-	✓	12 ch, 10-bit	2	-	0/4	1/0	-	2/0/1	4	-	1	-	-	1/0	1	-
PIC16F1718	28	28	2K	-	✓	17 ch, 10-bit	2	2/0	0/2	0/1	1/1	2/0/1	4	-	1	✓	2	1/0	1	-
PIC16F18855	44	14	1K	256	-	24 ch, 10-bit	2	5/0	0/2	3/0	1/0	3/0/4	4	2	3	✓	-	1/0	-	2
ATtiny1617	24	16	2K	256	-	24 ch, 10-bit	3	3/0	4/0	-	0/3	0/1/3	1	-	-	✓	-	1/0	-	1/1
ATtiny3217	24	32	2K	256	-	24 ch, 10-bit	3	3/0	4/0	-	0/3	0/1/3	1	-	-	✓	-	1/0	-	1/1
ATSAMD20	14	16	2K	-	-	14-ch 12-bit	2	8/8	12x 16-bit	-	1 x 12-bit	0/5/2	-	-	-	✓	-	6/0	-	6/6
ATSAMC20	32	256	32K	4K	-	2x10-ch 12-bit	4	10/10	10x 32-bit	-	1 x 12-bit	0/5/2	-	-	-	✓	-	4/0	-	4/4

Recommended Microcontrollers for Entry-level AC Induction Motor Control

Device	Pins	Flash (KB)	SRAM (Bytes)	EE (Bytes)	HEF	ADC	Comparator	CCP/ECCP	PWM (8-/10-bit)	CWG/COG	DAC (5-/8-bit)	Timer (8-/12-/16-bit)	CLC	SMT	NCO	PPS	Op Amp	EUSART/AUSART	MSSP	SPI/I ² C
PIC16F15323	14	3.5	256	-	✓	11 ch, 10-bit	2	2/0	0/4	1/0	1/0	1/0/2	4	-	1	✓	-	1/0	1	-
PIC16F15355	28	14	1K	-	✓	24 ch, 10-bit	2	2/0	0/4	1/0	1/0	1/0/2	4	-	1	✓	-	2/0	-	2/2
PIC16F1509	20	14	512	-	✓	12 ch, 10-bit	2	-	0/4	1/0	-	2/0/1	4	-	1	-	-	1/0	1	-
PIC16F1718	28	28	2K	-	✓	17 ch, 10-bit	2	2/0	0/2	0/1	1/1	2/0/1	4	-	1	✓	2	1/0	1	-
PIC16F18855	44	14	1K	256	-	24 ch, 10-bit	2	5/0	0/2	3/0	1/0	3/0/4	4	2	3	✓	-	1/0	-	2
ATtiny1617	24	16	2K	256	-	24 ch, 10-bit	3	3/0	4/0	-	0/3	0/1/3	1	-	-	✓	-	1/0	-	1/1
ATtiny3217	24	32	2K	256	-	24 ch, 10-bit	3	3/0	4/0	-	0/3	0/1/3	1	-	-	✓	-	1/0	-	1/1
ATSAMD20	14	16	2K	-	-	14 ch 12-bit	2	8/8	12x 16-bit	-	1 x 12-bit	0/5/2	-	-	-	✓	-	6/0	-	6/6
ATSAMC20	32	256	32K	4K	-	2x10 ch 12-bit	4	10/10	10x 32-bit	-	1 x 12-bit	0/5/2	-	-	-	✓	-	4/0	-	4/4

Recommended High-Performance Controllers for Advanced Brushless DC Motor, PMSM and ACIM Control

Device Family	Core	Pins	Flash (KB)	RAM (KB)	DMA # Ch	Timer 16-bit	Input Capture, Output Compare, Standard PWM	Motor Control (PWM Channels)	QEI	ADC	Analog Comparators	Op Amps	UART	SPI	I2C	PMP	RTCC	CAN	USB 2.0	Package	Temperature Range
dsPIC33EPxxxMC20x/ dsPIC33EPxxxMC50x	dsPIC33E	28-64	32-512	4-48	4	5	4-OC 4-IC,	6	1	1 ADC, 6-16 ch	1	3 ⁽¹⁾	2	2	2	-	-	0/1	-	SPDIP, SOIC, SSOP, QFN, UQFN, VTLA, TQFP	I, E, H
dsPIC33EPxxxGM3x/ dsPIC33EPxxxGM6x/ dsPIC33EPxxxGM7x	dsPIC33E	44-100	128- 512	16-48	4	9	8-IC, 8-OC	12	2	2 ADC, 18-49 ch	1	4 ⁽¹⁾	4	3	2	0/1	0/1	0/2	-	QFN TQFP, TFBGA	I, E, H
dsPIC33EVxxxGM00x/ dsPIC33EVxxxGM10x	dsPIC33E	28-64	32-256	4-16	4	5	4-OC 4-IC,	6	-	1 ADC, 11-36 ch	1	4 ⁽¹⁾	2	2	1	-	-	0/1	-	SPDIP, SOIC, SSOP, QFN, UQFN, TQFP	I, E, H
dsPIC33CKxxMC10x	dsPIC33C	28 - 48	32 - 64	8	4	1	4 -CCP	8	1	1 ADC, 11-15 ch	1	3	3	2	1	-	-	-	-	UQFN, SSOP, TQFP	I, E, H
dsPIC33CKxxMP10x/ dsPIC33CKxxxMP20x/ dsPIC33CKxxxMP50x	dsPIC33C	28-80	32-256	8-24	4	1	5/9- CCP	8/16	2	1 ADC, 12-24 ch	3	3	3	3	3	0/1	-	0/1 ⁽²⁾	-	SSOP, UQFN, TQFP	I, E, H
dsPIC33CHxxxMP20x/ dsPIC33CHxxxMP50x	Dual Core dsPIC33C	28-80	64-512	20-48	8	2	12- CCP	24	2	4 ADC, 12-18 ch	4	3	3	3	3	-	-	0/1/2 ⁽²⁾	-	SSOP, UQFN, TQFP	I, E, H
PIC32MKxxxxMCJxxx	MIPS32® microAptiv™	48-64	256- 512	64	10	9	9-OC 9-IC	18	3	7 ADC, 18-30 ch	5	4	2	2	2	-	1	1	-	UQFN, VQFN, TQFP	I, E
PIC32MKxxxxMCMxxx	MIPS32 microAptiv	64-100	512- 1024	128- 256	21	9	16-OC 16-IC,	24	6	7 ADC, 26-42 ch	5	4	6	6	4	Yes	1	4	2	VQFN, TQFP	I, E
PIC32MKxxxxMCFxxx	MIPS32 microAptiv	64-100	512- 1024	128- 256	21	14	16-OC 16-IC,	24	6	7 ADC, 16-42 ch	5	4	6	6	Yes	Yes	1	4	1	VQFN, TQFP	I, E
ATSAMC20xxx/ ATSAMC21xxx	CM0+	32-100	32-256	4-32	6	8 - TC	14	-	-	2 ADC, 20 ch	4	-	4/8	-	-	1	0/2 ⁽²⁾	-	VQFN, TQFP, WLCSP	I, E	
ATSAMD10xxx/ ATSAMD11xxx	CM0+	14-64	8-256	4-32	0/6	2 - TC	8	-	-	1 ADC, 10 ch	2	-	3	-	1	-	-	0/1	QFN, SOIC, WLCSP	I, E	
ATSAMD20xxx/ ATSAMD21xxx	CM0+	32-64	16-256	2-32	-	5 - TC	0/22	-	-	1 ADC, 20 ch	2	-	6	-	1	-	-	0/1	TQFP, QFN, UFBGA, WLCSP	I, E	
ATSAMDA1xx	CM0+	32-64	16-64	4-8	8	5 - TC	14	-	-	1 ADC, 20 ch	2	-	6	-	1	-	-	1	QFN, TQFP	I, E	
ATSAMD5xxxx/ ATSAME5xxxx	CM4F	64-128	256- 1024	128- 256	32	8 - TC	23	1	-	2 ADC, 32 ch	2	-	8	-	1	-	0/2 ⁽²⁾	1	QFN, TQFP, TFBGA, WLCSP	I, E	
ATSAMS7xxxx/ ATSAME7xxxx	CM7	64-144	512- 2048	256- 384	24	12 - TC	16	4	-	2 ADC, 24 ch	1	-	5	3	5	-	1	2 ⁽²⁾	1	QFN, LQFP, LFBGA, TFBGA, UFBGA, VFBGA	I, E

Note 1: Op amps can be configured as comparators. 2: Supports both CAN 2.0 and CAN FD 3: I = Industrial Temperature Range (-40°C to +85°C), E = Extended Temperature Range (-40°C to +125°C), H = High Temperature Range (-40°C to +150°C). 4: IC = Input Capture module, OC = Output Compare PWM module, CCP = Capture Compare PWM module, TC = Timer Counters module Check www.microchip.com for availability

Recommended Motor Drivers for 3-Phase Brushless Motors

Part #	Input Voltage Range (V)	Internal/ External FETs	Output Current (mA)	Control Scheme	Motor Speed Output	Protections	Temperature Operating Range (°C)	Features	Packages
ATA6843	5.5 to 32	External	100	Direct PWM	–	Short Circuit, Overtemperature, Over/Under Voltage, Chargepump Fail	–40 to +125	Charge pump supply for external battery reverse protection NMOS, Dead time adjust, LDO 3.3V/5V, Window Watchdog, LIN TRX, Sleep mode <45 µA	48-pin 7 × 7 QFN
ATA6844	5.5 to 32	External	100	Direct PWM	–	Short Circuit, Overtemperature, Over/Under Voltage, Chargepump Fail	–40 to +150	Charge pump supply for external battery reverse protection NMOS, Dead time adjust, LDO 3.3V/5V, Window Watchdog, LIN TRX, Sleep mode <45 µA	48-pin 7 × 7 QFN
MCP8063	2.0 to 14.0	Internal	750	Sensorless Sinusoidal	✓	Overtemperature, Motor Lock-up, Overcurrent, Overvoltage	–40 to +125	3-Phase BLDC 180° Sinusoidal Sensorless Fan Motor Driver, Overcurrent Limitation, Output Switching Frequency at 23 kHz	Thermally Enhanced 8-pin 4 × 4 DFN
MTD6501C	2.0 to 14.0	Internal	800	Sensorless Sinusoidal	✓	Overtemperature, Motor Lock-up, Overcurrent, Overvoltage	–30 to +95	3-Phase BLDC 180° Sinusoidal Sensorless Fan Motor Driver, Overcurrent limitation, Output Switching Frequency at 20 kHz	Thermally Enhanced 8-pin SOP
MTD6501D	2.0 to 14.0	Internal	500	Sensorless Sinusoidal	✓	Overtemperature, Motor Lock-up, Overcurrent, Overvoltage	–30 to +95	3-Phase BLDC 180° Sinusoidal Sensorless Fan Motor Driver, Boost Mode, Overcurrent limitation, Output Switching Frequency at 20 kHz	10-pin MSOP
MTD6501G	2.0 to 14.0	Internal	800	Sensorless Sinusoidal	✓	Overtemperature, Motor Lock-up, Overcurrent, Overvoltage	–30 to +95	3-Phase BLDC 180° Sinusoidal Sensorless Fan Motor Driver, Overcurrent limitation, Output Switching Frequency at 23 kHz	Thermally Enhanced 8-pin SOP
MTD6502B	2.0 to 5.5	Internal	750	Sensorless Sinusoidal	✓	Overtemperature, Motor Lock-up, Overcurrent, Overvoltage	–40 to +125	3-Phase BLDC Sinusoidal Sensorless Fan Motor Driver, Direction control, Overcurrent limitation, Output Switching Frequency at 30 kHz	10-pin 3 × 3 TDFN
MTD6508	2.0 to 5.5	Internal	750	Sensorless Sinusoidal	✓	Overcurrent, Overvoltage, Overtemperature, Motor Lock-up	–40 to +125	180° Sinusoidal Sensorless Drive, Direction Control, Programmable BEMF Coefficient Range, Output Switching Frequency at 30 kHz, Programmable Start-up RPM and Slew Rate, Selectable Start-up Strength and Phase Target Regulation	10-pin 3 × 3 UDFN, 16-pin 4 × 4 UQFN
MTD6505	2.0 to 5.5	Internal	750	Sensorless Sinusoidal	✓	Overcurrent, Overvoltage, Overtemperature, Motor Lock-up	–40 to +125	180° Sinusoidal Sensorless Drive, Direction Control, Programmable BEMF Coefficient Range, Output Switching Frequency at 30 kHz	10-pin 3 × 3 UDFN

Recommended MOSFET Gate Drivers for 3-Phase Brushless Motors

Device	Configuration	Temp. Operating Range (°C)	Peak Output Current (A)	Output Resistance (Rh/RI) (Max. Ω @ 25°C)	Maximum Supply Voltage (V _{dd} , V _{supply}) (V)	Input/ Output Delay (td1, td2) (ns)	Packages
MCP14700	Half bridge	–40 to +125	2	2.5/2.5	5, 36	27/17	8-pin SOIC, 8-pin 3 × 3 DFN
MIC4605	Half bridge	–40 to +125	1	12	16, 85	35/35	8-pin SOIC, 10-pin 2.5 × 2.5 TDFN
MIC4606	H-bridge	–40 to +125	1	12	16, 85	35/35	16-pin QFN, 16-pin 4 × 5 TSSOP
MIC4103/4104	Half bridge	–40 to +125	3	2.5/1.5	16, 100	24/24	8-pin SOIC

Recommended Operational Amplifiers

Device	# per Package	GBWP (MHz)	Iq Typical (µA)	Vos Max (mV)	Operating Voltage (V)	Features	Packages
MCP6V31/2/4	1/2/4	0.3	23	0.008	1.8 to 5.5	Zero-Drift Architecture, Rail-to-Rail Input/Output	TSSOP, MSOP, TDFN, SOT, SC70
MCP6401/2/4	1/2/4	1	45	4.5	1.8 to 6.0	Rail-to-Rail Input/Output, Low Operating Voltage	SOIC, TSSOP, TDFN, SOT, SC70
MCP6V51	1	2	470	0.015	4.5 to 45	Zero-Drift Architecture, Rail-to-Rail Output, Enhanced EMI Rejection, High Operating Voltage	SOT, MSOP
MCP6291/2/4	1/2/4	10	1000	3.0	2.4 to 6.0	Rail-to-Rail Input/Output	PDIP, SOIC, MSOP, TSSOP, SOT
MCP6V91/2/4	1/2/4	10	1100	0.009	2.4 to 5.5	Zero-Drift Architecture, Rail-to-Rail Input/Output, Enhanced EMI Rejection	TSSOP, MSOP, TDFN, SOT, SC70
MCP631/2/3/4/5/9	1/2/1/4/2/4	24	2500	8	2.5 to 5.5	Rail-to-Rail Output, Chip Select (on select devices)	SOIC, MSOP, DFN, TSSOP, QFN, SOT

Recommended High-Side Current Sense Amplifiers

Device	Input Common Mode Range (V)	Vos Max (µV)	Vos Drift Max (nV/°C)	Max Gain Error (%)	Bandwidth (kHz)	Iq Max (mA)	Operating Voltage (V)	Temperature Range (°C)	Features	Packages
MCP6C02	3 to 65	16	85	1.6	500	0.75	2 to 5.5	-40 to +125	Bidirectional Current Sense Amplifier, Enhanced EMI Rejection	6-pin SOT-23
MCP6C04	3 to 52	30	180	1.6	500	0.84	2 to 5.5	-40 to +125	Bidirectional Current Sense Amplifier, Enhanced EMI Rejection	6-pin SOT-23

Recommended LDOs

Device	Max. Input Voltage (V)	Output Voltage (V)	Output Current (mA)	Junction Temp. Range (°C)	Typical Active Current (µA)	Typical Dropout Voltage @ Max. Iout (mV)	Typical Output Voltage Accuracy (%)	Features	Packages
MIC5205	2.5 to 16	2.5, 2.7, 2.8, 2.85, 2.9, 3.0, 3.1, 3.2, 3.3, 3.6, 3.8, 4.0, 5.0, Adj.	150	-40 to +125	80	165	±1	Ultra-low noise output	5-pin SOT-23
MCP1754	16	1.8, 2.5, 2.7, 2.8, 2.85, 3.0, 3.3, 3.6, 4.0, 5.0	150	-40 to +125	50	300	±2	70 dB PSRR	5-pin SOT-23, 3-pin, SOT-89, 3-pin SOT-223, 8-pin 2 × 3 TDFN

Application Notes

Motor Type/Algorithm By MCU and DSC Device Family

Motor Type	Algorithm	PIC16 Family	PIC18 Family	AVR® Family	dsPIC® DSC Family	PIC32 or SAM MCU Family
Stepper Motor	Motor Control Theory	AN907				
	Full- and Half-Stepping	AN906, AN2326	–	AN8017	AN1307	
	Micro-Stepping	AN2326	AN822		AN1307	
Brushed DC Motor	Motor Control Theory	AN905				
	Uni-Directional	AN905	–		–	
	Bi-Directional	AN893	–		–	
	Servo Motor	AN532, AN696	AN696, AN3409		–	
Three Phase BLDC and PMSM	Motor Control Theory	AN857, AN885, AN7671				
	Sensored	–	AN899	AN2522, AVR194, AN7672	AN957	42711A
	Sensored Sinusoidal	AN2557	–	AN8010, AN8030	AN1017	AN2757
	Sensorless BEMF	AN857, AN1175, AN1305	AN970	AN8012, AN7658, AN_8306	AN901, AN992	
	Sensorless Filtered BEMF with Majority Detect	–	–		AN1160	
	Sensorless Dual-Shunt FOC with Reduced Order Luenberger Observer	–	–		–	AN2590
	Sensorless Dual-Shunt FOC with SMO Estimator and Field Weakening	–	–		AN1078	
	Sensorless Dual-Shunt FOC with SMO and PFC	–	–		AN1208	
	Sensorless Dual-Shunt FOC with PLL Estimator and Field Weakening	–	–		AN1292	AN2520
	Sensorless Dual-Shunt FOC with PLL Estimator and PFC	–	–		–	AN2584
	Sensorless Single-Shunt FOC with SMO Estimator and Field Weakening	–	–	AN42061	AN1299	
Single Phase BLDC	Sensored	AN1779, AN2049				
Two Phase BLDC	Sensored	AN1178		AVR440, AVR441, AVR442		
Three Phase ACIM	Motor Control Theory	AN887				
	Open Loop V/F	AN889, AN955, AN967, AN1660	AN900, AN843	AN7545	AN984	
	Closed Loop Vector Control	–	–	AN7546	AN908	
	Sensorless Dual-Shunt FOC with PLL Estimator	–	–		AN1162	
	Sensorless Dual-Shunt FOC with PLL Estimator and Field Weakening	–	–		AN1206	
Single Phase ACIM	Open Loop V/F	AN1660				
Other	PFC	–	–		AN1106	
	Appliance Class B (IEC 60730)	–	AN1229		AN1229	
	Motor Control Sensor Feedback Circuits	AN894				
	MOSFET Driver Selection	AN898				
	Current Sensing Circuit Concepts and Fundamentals	AN1332				

Support

Microchip is committed to supporting its customers in developing products faster and more efficiently. We maintain a worldwide network of field applications engineers and technical support ready to provide product and system assistance. For more information, please visit www.microchip.com:

- Technical Support: www.microchip.com/support
- Evaluation samples of any Microchip device: www.microchip.com/sample
- Knowledge base and peer help: www.microchip.com/forums
- Sales and Global Distribution: www.microchip.com/sales

Training

If additional training interests you, Microchip offers several resources including in-depth technical training and reference material, self-paced tutorials and significant online resources.

- Overview of Technical Training Resources: www.microchip.com/training
- MASTERS Conferences: www.microchip.com/masters
- Developer Help Website: www.microchip.com/developerhelp
- Technical Training Centers: www.microchip.com/seminars

Sales Office Listing

AMERICAS

Atlanta, GA
Tel: 678-957-9614

Austin, TX
Tel: 512-257-3370

Boston, MA
Tel: 774-760-0087

Chandler, AZ (HQ)
Tel: 480-792-7200

Chicago, IL
Tel: 630-285-0071

Dallas, TX
Tel: 972-818-7423

Detroit, MI
Tel: 248-848-4000

Houston, TX
Tel: 281-894-5983

Indianapolis, IN
Tel: 317-773-8323
Tel: 317-536-2380

Los Angeles, CA
Tel: 949-462-9523
Tel: 951-273-7800

Raleigh, NC
Tel: 919-844-7510

New York, NY
Tel: 631-435-6000

San Jose, CA
Tel: 408-735-9110
Tel: 408-436-4270

Canada - Toronto
Tel: 905-695-1980

EUROPE

Austria - Wels
Tel: 43-7242-2244-39

Denmark - Copenhagen
Tel: 45-4450-2828

Finland - Espoo
Tel: 358-9-4520-820

France - Paris
Tel: 33-1-69-53-63-20

Germany - Garching
Tel: 49-8931-9700

Germany - Haan
Tel: 49-2129-3766-400

Germany - Heilbronn
Tel: 49-7131-67-3636

Germany - Karlsruhe
Tel: 49-721-62537-0

Germany - Munich
Tel: 49-89-627-144-0

Germany - Rosenheim
Tel: 49-8031-354-560

EUROPE

Israel - Ra'anana
Tel: 972-9-744-7705

Italy - Milan
Tel: 39-0331-742611

Italy - Padova
Tel: 39-049-7625286

Netherlands - Drunen
Tel: 31-416-690399

Norway - Trondheim
Tel: 47-7289-7561

Poland - Warsaw
Tel: 48-22-3325737

Romania - Bucharest
Tel: 40-21-407-87-50

Spain - Madrid
Tel: 34-91-708-08-90

Sweden - Gothenberg
Tel: 46-31-704-60-40

Sweden - Stockholm
Tel: 46-8-5090-4654

UK - Wokingham
Tel: 44-118-921-5800

ASIA/PACIFIC

Australia - Sydney
Tel: 61-2-9868-6733

China - Beijing
Tel: 86-10-8569-7000

China - Chengdu
Tel: 86-28-8665-5511

China - Chongqing
Tel: 86-23-8980-9588

China - Dongguan
Tel: 86-769-8702-9880

China - Guangzhou
Tel: 86-20-8755-8029

China - Hangzhou
Tel: 86-571-8792-8115

China - Hong Kong SAR
Tel: 852-2943-5100

China - Nanjing
Tel: 86-25-8473-2460

China - Qingdao
Tel: 86-532-8502-7355

China - Shanghai
Tel: 86-21-3326-8000

China - Shenyang
Tel: 86-24-2334-2829

China - Shenzhen
Tel: 86-755-8864-2200

China - Suzhou
Tel: 86-186-6233-1526

China - Wuhan
Tel: 86-27-5980-5300

China - Xiamen
Tel: 86-592-2388138

China - Xian
Tel: 86-29-8833-7252

ASIA/PACIFIC

China - Zhuhai
Tel: 86-756-321-0040

India - Bangalore
Tel: 91-80-3090-4444

India - New Delhi
Tel: 91-11-4160-8631

India - Pune
Tel: 91-20-4121-0141

Japan - Osaka
Tel: 81-6-6152-7160

Japan - Tokyo
Tel: 81-3-6880-3770

Korea - Daegu
Tel: 82-53-744-4301

Korea - Seoul
Tel: 82-2-554-7200

Malaysia - Kuala Lumpur
Tel: 60-3-7651-7906

Malaysia - Penang
Tel: 60-4-227-8870

Philippines - Manila
Tel: 63-2-634-9065

Singapore
Tel: 65-6334-8870

Taiwan - Hsin Chu
Tel: 886-3-577-8366

Taiwan - Kaohsiung
Tel: 886-7-213-7830

Taiwan - Taipei
Tel: 886-2-2508-8600

Thailand - Bangkok
Tel: 66-2-694-1351

Vietnam - Ho Chi Minh
Tel: 84-28-5448-2100

5/15/19



www.microchip.com

Microchip Technology Inc. | 2355 W. Chandler Blvd. | Chandler AZ, 85224-6199