

MiniZed™ is a single-core Zynq 7Z007S development board. With the advent of the latest cost-optimized portfolio from Xilinx, this board targets entry-level Zynq developers with a low-cost prototyping platform.

This compact design features on-board connectivity through USB, Wi-Fi and Bluetooth. Peripherals can be plugged into dual Pmod-compatible connectors, the Arduino-compatible shield interface or the USB 2.0 host interface. JTAG circuitry is incorporated onto the MiniZed base board, so with a single micro-USB cable to your laptop you are already up and running. User LED's, a button and a switch allow for a physical board interface.

Micron memory solutions are presented for QSPI flash, DDR3L memory and on-board eMMC instead of an external SD card. The Murata Type 1DX wireless solution incorporates 802.11b/g/n Wi-Fi as well as Bluetooth 4.1, which provides both Bluetooth Classic and Low Energy (BLE). The integrated power supply from Dialog generates all on-board voltages, while an auxiliary supply input can be used to power designs that require additional current. From ST Microelectronics there is an on-board motion and temperature sensor, as well as a digital microphone.

MiniZed provides for an efficient hardware reference design, while it is also an inexpensive board that can be used to run workshops and tutorials. The board aims to showcase the power of Zynq, where the Cortex-A9 processor core integrates seamlessly with the programmable fabric to provide signal processing and control solutions. The on-board digital microphone serves as an input for a variety of illustrations of how to implement FIR filters, FFT's and direct memory access.

FEATURES

- Xilinx Zynq XC7Z007S SoC
- Micron 512 MB DDR3L
- Micron 128 MB QSPI flash
- Micron 8GB eMMC mass storage
- On-board USB to JTAG and debug UART circuit
- Murata "Type 1DX" wireless module with 802.11b/g/n Wi-Fi and Bluetooth 4.1 plus EDR and BLE (Bluetooth Low Energy)
- USB 2.0 host interface
- Dialog Semiconductor DA9062 PMIC (Power Management IC)
- Arduino-compatible shield interface
- 2 x Pmod-compatible interfaces
- STMicroelectronics LIS2DS12 Accelerometer and Temperature sensor
- STMicroelectronics MP34DT05 digital MEMS microphone
- Reset button, user button, user switch, 2 x user bi-element LEDs

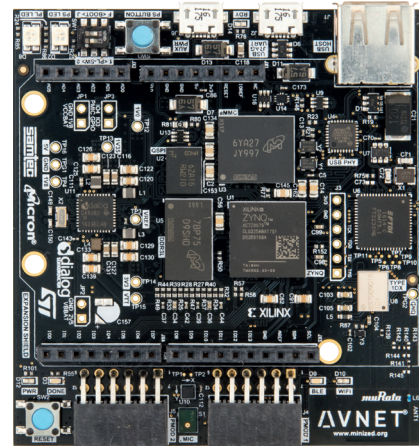

KIT INCLUDES

- MiniZed development board
- Voucher for SDSoC license from Xilinx
- Micro USB cable

OPTIONAL ADD-ON ITEMS

- Additional external 2.4A @ 5V power supply with micro USB cable
- Digilent "Pmod SD" for using an SD card
- SD card

TARGET APPLICATIONS

- Entry level/low-cost Zynq development environment
- Training, prototyping and proof-of-concept demo platform
- Wireless design and demonstrations using Wi-Fi and Bluetooth
- Audio signal processing examples using the microphone input
- IoT/cloud connectivity for on-board and peripheral sensors

COMPATIBILITY

/MINIZED™



BLOCK DIAGRAM

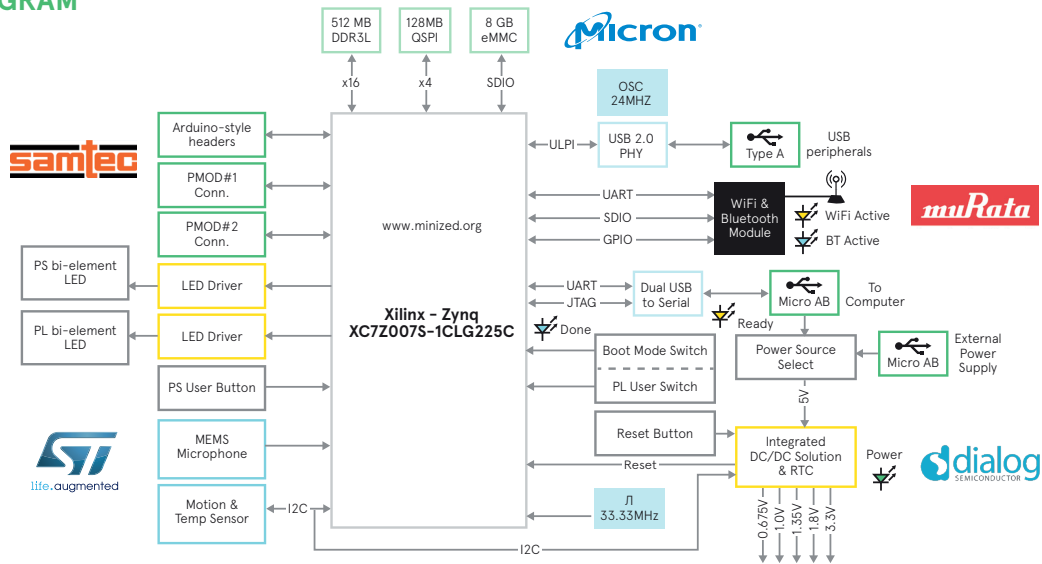

FEATURED MANUFACTURERS



PARTS

Part Number	Description
AES-MINIZED-7Z007-G	MiniZed™ Single-core Zynq 7Z007S Development Board

RELATED PARTS

Part Number	Description
AES-ACC-MINIZ-PWR	External power supply kit (micro-USB cable & 5V 2A wall plug power adapter)

Pricing: See online catalog avnet-silica.com

CONTACT INFORMATION

AUSTRIA
Vienna: wien@avnet.eu

BELGIUM
Merebeke: gent@avnet.eu

CZECH REPUBLIC (SLOVAKIA)
Prague: praha@avnet.eu

DENMARK
Herlev: herlev@avnet.eu

ESTONIA (LATVIA, LITHUANIA)
Pärnu: paernu@avnet.eu

FINLAND
Espoo: helsinki@avnet.eu

FRANCE (TUNISIA)
Cesson Sévigné: rennes@avnet.eu
Illkirch: strasbourg@avnet.eu
Massy Cedex: paris@avnet.eu
Toulouse: toulouse@avnet.eu
Vénissieux Cedex: lyon@avnet.eu

GERMANY
Berlin: berlin@avnet.eu
Braunschweig: braunschweig@avnet.eu
Freiburg: freiburg@avnet.eu
Hamburg: hamburg@avnet.eu
Herne: herne@avnet.eu
Holzwickede: holzwickede@avnet.eu
Leinfelden-Echterdingen: stuttgart@avnet.eu
Leipzig: leipzig@avnet.eu
Nürnberg: nuernberg@avnet.eu
Poing: muenchen@avnet.eu
Wiesbaden: wiesbaden@avnet.eu

HUNGARY
Budapest: budapest@avnet.eu

ITALY
Cusano Milanino: milano@avnet.eu
Firenze: firenze@avnet.eu
Modena: modena@avnet.eu
Padova: padova@avnet.eu
Rivoli: torino@avnet.eu
Roma Tecnocittà: roma@avnet.eu

NETHERLANDS
Breda: breda@avnet.eu

NORWAY
Asker: asker@avnet.eu

POLAND
Gdansk: gdansk@avnet.eu
Katowice: katowice@avnet.eu
Warszawa: warszawa@avnet.eu

PORTUGAL
Vila Nova de Gaia: porto@avnet.eu

ROMANIA (BULGARIA)
Bucharest: bucaresti@avnet.eu

RUSSIA (BELARUS, UKRAINE)
Moscow: moscow@avnet.eu
Saint Petersburg: stpetersburg@avnet.eu

SLOVENIA (BOSNIA AND HERZEGOVINA, CROATIA, MACEDONIA, MONTENEGRO, SERBIA)
Ljubljana: ljubljana@avnet.eu

SPAIN
Barcelona: barcelona@avnet.eu
Galdacano, Vizcaya: bilbao@avnet.eu
Las Matas: madrid@avnet.eu

SWEDEN
Sundbyberg: stockholm@avnet.eu

SWITZERLAND
Rothrist: rothrist@avnet.eu

TURKEY (GREECE, EGYPT)
Kadikoy Istanbul: istanbul@avnet.eu

UNITED KINGDOM (IRELAND)
Berkshire: maidenhead@avnet.eu
Bolton: bolton@avnet.eu
Bucks, Aylesbury: aylesbury@avnet.eu
Stevenage, Herts, Meadway: stevenage@avnet.eu



All trademarks and logos are the property of their respective owners. This document provides a brief overview only, no binding offers are intended. No guarantee as to the accuracy or completeness of any information. All information is subject to change, modifications and amendments without notice.