

## Important notice

Dear Customer,

On 7 February 2017 the former NXP Standard Product business became a new company with the tradename **Nexperia**. Nexperia is an industry leading supplier of Discrete, Logic and PowerMOS semiconductors with its focus on the automotive, industrial, computing, consumer and wearable application markets

In data sheets and application notes which still contain NXP or Philips Semiconductors references, use the references to Nexperia, as shown below.

Instead of <http://www.nxp.com>, <http://www.philips.com/> or <http://www.semiconductors.philips.com/>, use <http://www.nexperia.com>

Instead of [sales.addresses@www.nxp.com](mailto:sales.addresses@www.nxp.com) or [sales.addresses@www.semiconductors.philips.com](mailto:sales.addresses@www.semiconductors.philips.com), use [salesaddresses@nexperia.com](mailto:salesaddresses@nexperia.com) (email)

Replace the copyright notice at the bottom of each page or elsewhere in the document, depending on the version, as shown below:

- © NXP N.V. (year). All rights reserved or © Koninklijke Philips Electronics N.V. (year). All rights reserved

Should be replaced with:

- © **Nexperia B.V. (year). All rights reserved.**

If you have any questions related to the data sheet, please contact our nearest sales office via e-mail or telephone (details via [salesaddresses@nexperia.com](mailto:salesaddresses@nexperia.com)). Thank you for your cooperation and understanding,

Kind regards,

Team Nexperia

# AN11304

## MOSFET load switch PCB with thermal measurement

Rev. 1 — 25 January 2013

Application note

### Document information

Info	Content
<b>Keywords</b>	Load switch, MOSFETs, DFN2020MD-6 (SOT1220), DFN2020-6 (SOT1118); DFN3333-8 (SOT873-1), thermal resistance
<b>Abstract</b>	This document describes a demonstration Printed-Circuit Board (PCB) with identical load switch MOSFET crystals in a DFN2020, DFN3333 and an SO-8 package which can be compared depending on their thermal performance. A sensor measures the temperature of the drain pad. A microcontroller calculates a solder point temperature from this measurement result. Finally this value is displayed on an LCD display. With increasing space constraints in compact applications like tablet PCs, ultralight PCs and smartphones, smaller packages are requested to raise the power density.



## Revision history

Rev	Date	Description
1	20130125	Initial version

## Contact information

For more information, please visit: <http://www.nxp.com>

For sales office addresses, please send an email to: [salesaddresses@nxp.com](mailto:salesaddresses@nxp.com)

## 1. Introduction

Modern electronic systems consist of separate functional blocks, which can be activated and deactivated independently. Many systems need a specific turn-on and turn-off sequence for a proper system start and shutdown. In order to save energy and to extend battery life time, some blocks can be activated only if necessary. MOSFETs are used as load path switching element in so-called load switch applications to support this function.

In line with the industry trend towards smaller electronic devices like tablet PCs, ultralight PCs and smartphones, MOSFETs in smaller packages are used in the designs. Modern MOSFETs can combine a low turn-on resistance with small space requirements paving the road towards a higher power density, measured in Watts per mm<sup>2</sup>.

This document describes a demonstration PCB with identical MOSFET crystals in a DFN2020, a DFN3333 and an SO-8 package which can be compared depending on their thermal performance. A sensor measures the temperature of each drain pad. A microcontroller calculates a solder point temperature from this measurement result. Finally this value is displayed on an LCD display.

## 2. Load switch topologies

### 2.1 High-side switch

In many applications, the positive supply voltage shall be switched. A load switch usually consists of a switching element in the load path itself and a second electronic part as control element. [Figure 1](#) shows the general structure of a high-side load switch.

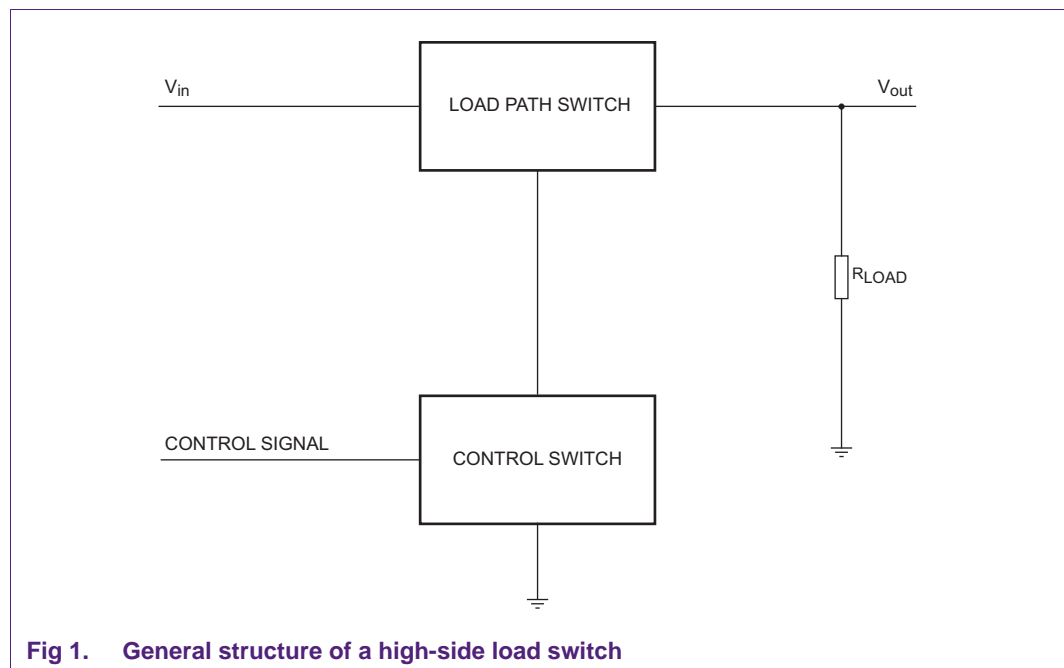
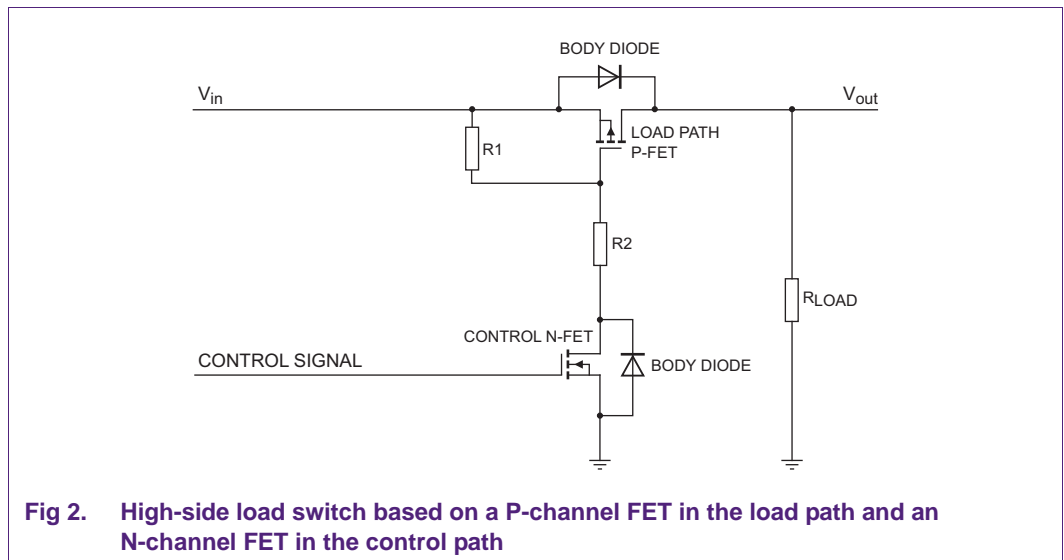

Fig 1. General structure of a high-side load switch

For the switches, MOSFETs are the most efficient solution because they are controlled by a voltage only: they do not generate static control losses. In a bipolar transistor, a permanent base current must be provided in the ON-state. The most simple circuit for a

MOSFET-based high-side load switch is depicted in [Figure 2](#). The schematic shows body diodes which are part of every MOSFET reminding that MOSFETs cannot provide a reverse current protection.

A P-channel FET is applied in the load path. It switches on if the gate is pulled down to ground via the N-channel control FET. The resistor R1 is required to get the load path FET properly switched off and to get the parasitic capacitors of the transistor discharged. A complete resistor divider built by the resistors R1 and R2 is only needed if the input voltage  $V_{in}$  is higher than the maximum allowed gate-source voltage  $V_{GS}$  of the P-channel FET. The usage of a control FET has the advantage, that the load switch can handle rather high voltages in the load path. Moreover the control voltage of the control FET can be in the range of output voltages of logic ICs and processors. For a direct control of the P-channel FET, the high level of the control signal must be as high as  $V_{in}$ . This is not possible in many cases. The control FET works as a level translator and the complete load switch works with a positive control logic. So a high signal at the control input switches on the load path.



The calculation of the losses of this application is rather simple. There are the drain-source on-state resistance  $R_{DSon}$  losses of the P-channel FET and very small losses in the control path in the resistors R1 and R2.

$$P_{tot} = (I_{load})^2 \times R_{DSon} + (V_{in})^2 / (R1 + R2) \tag{1}$$

The second term of [Equation 1](#) can be neglected in most cases because there is no significant current needed in the gate path. A standard load switch is operated in a quasi-static scenario without tough requirements for switching times.

A very important aspect for the dimensioning of the resistor divider is a suitable target for the gate-source voltage of the P-channel FET. [Figure 3](#) shows the  $R_{DSon}$  curves versus the drain current  $I_D$  for PMPB15XP as an example. This diagram shows clearly that it is not sufficient to apply a gate voltage close to the gate-source threshold voltage  $V_{GS(th)}$  to switch a higher load current.  $V_{GS(th)}$  typical value is 0.68 V for PMPB15XP. This threshold voltage is defined for a rather low drain current ( $I_D = 250 \mu A$  for PMPB15XP). The consideration of the data sheet curves in [Figure 3](#) and the worst case tolerances are

mandatory for a safe design of a load switch. The circuit topology on [Figure 2](#) has a limitation in case that very small voltages have to be switched because  $V_{GS}$  cannot exceed  $V_{in}$  for the load path P-channel FET.

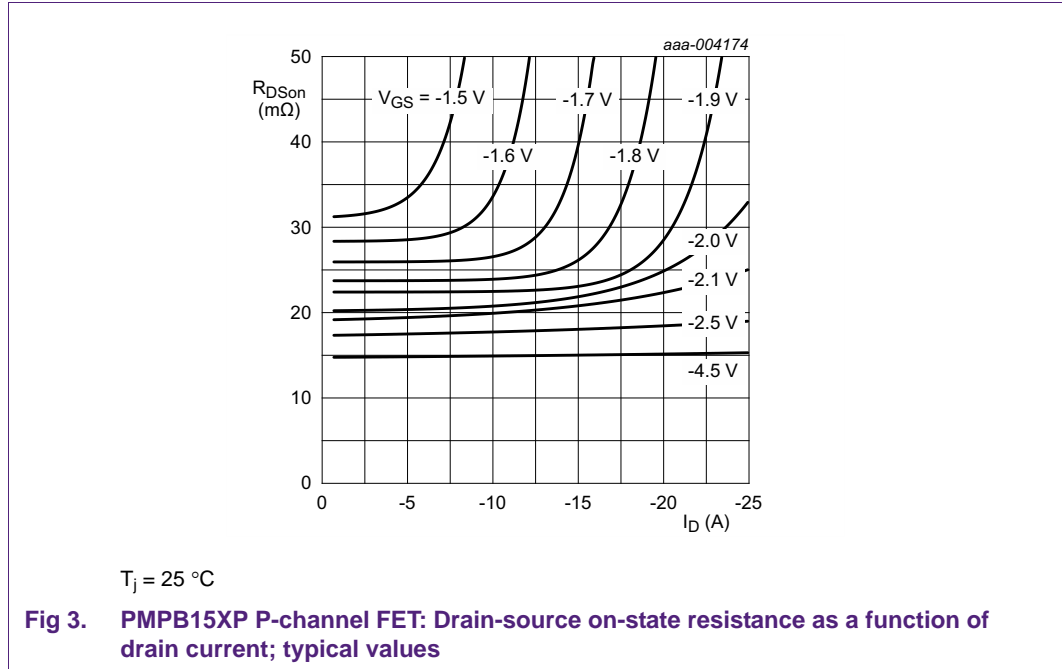

[Figure 4](#) shows a high-side load switch topology supporting switching of low input voltages. An auxiliary voltage  $V_{aux}$  higher than  $V_{in}$  provides enough headroom to activate the N-channel FET in the load path. In most of the computing and consumer applications, higher voltages of 5 V or 3.3 V are available in the system. In case a positive control logic is required, two N-channel FETs are implemented in the control path. The first FET operates as an inverter. With a dual FET, the package count is not increased. Dual FETs like NX3020NAKS (SOT363) and NX3020NAKV (SOT666) with a  $V_{DS(max)}$  of 30 V or NX7002AKS (SOT363) and 2N7002BKV (SOT666) with a  $V_{DS(max)}$  of 60 V are suitable components for this purpose.

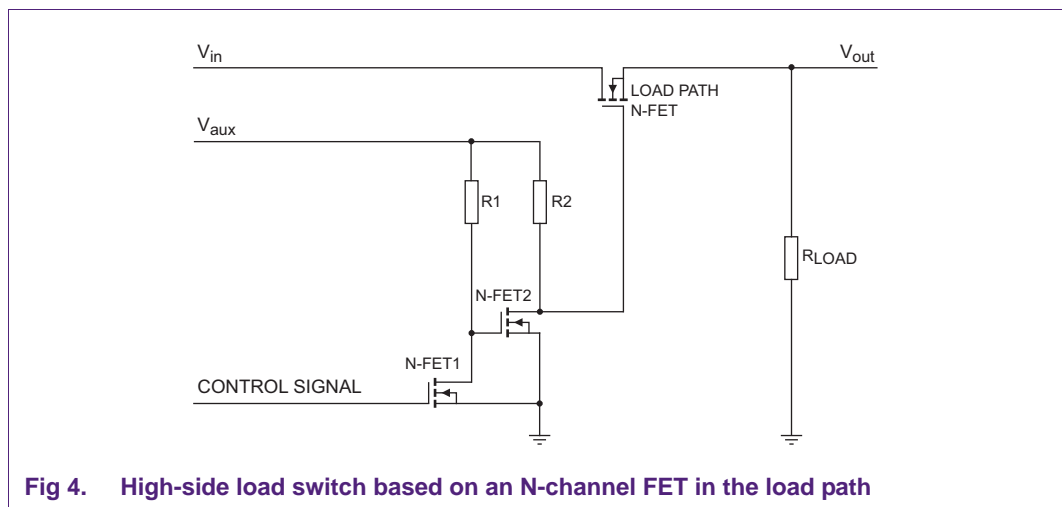

### 2.2 Low-side switch

If the load path switching element is placed into the ground connection of the load, the topology is called low-side switch. The control is getting even more simple compared to the high-side switch because in most cases an N-channel FET can be controlled directly from a driving device. [Figure 5](#) depicts the schematic diagram.

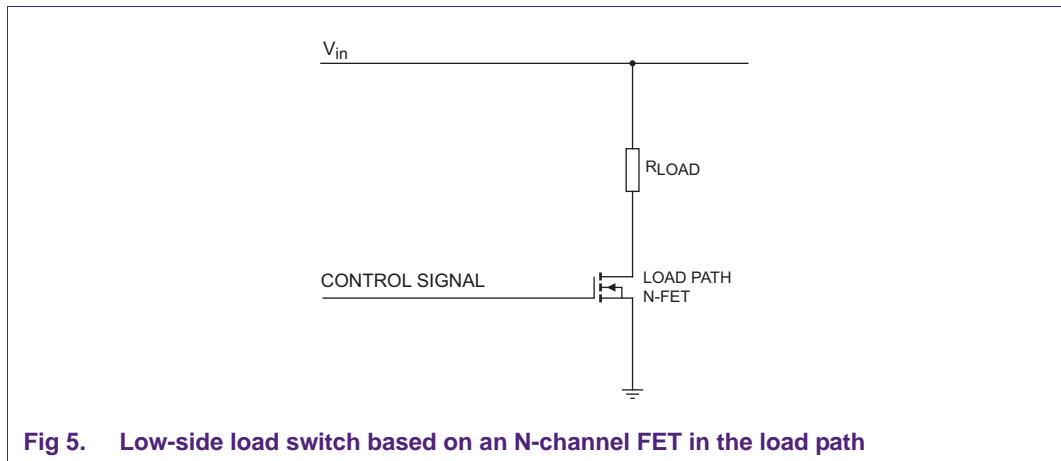

Fig 5. Low-side load switch based on an N-channel FET in the load path

## 3. Demonstration PCB for the evaluation of the thermal performance of MOSFETs in DFN2020, DFN3333 and SO-8

### 3.1 Hardware of the demonstration PCB

The demo board is designed to allow a comparison of the thermal performance of MOSFETs in the three packages DFN2020MD-6 (SOT1220), DFN3333-8 (SOT873-1) and SO-8 (SOT96). All three FETs are attached to a 1 cm<sup>2</sup> drain pad. Beside these identical mounting conditions, the same crystals are assembled into the packages. The MOSFETs work as low-side switches as shown in the schematic diagram on [Figure 6](#). LEDs indicate the active channel. The load switch FETs are driven by BSS138PW drivers which work as level converters from the microcontroller running at 3.3 V. Behind the BSS138PW stage, a 5 V drive voltage for the load switches is provided and ensures that the FETs can be switched on properly.

The load must be connected to the output connector of the active FET or FET under test (for example, the output pin DFN2020-OUT). The other side of the load must be connected to the positive pole of a power supplying the load. The negative poles of the power supplies are connected to the connector LOAD\_GND on the PCB, so that a loop for the load current is closed once the FET is switched on.

In the center of each drain pad, there is a PMBT3904MB NPN-transistor in a DFN1006B-3 (SOT883B) package. These bipolar transistors work as temperature sensors. The temperature measurement is based on the forward voltage variation  $\Delta V_F$  of a silicon PN-diode versus temperature. The thermal coefficient of  $V_F$  (typical) for a silicon diode at an operation point with a small current is approximately:

$$\Delta V_F / \Delta T = -1,7 \frac{mV}{K} \tag{2}$$

It means that the voltage across a diode decreases the higher the temperature gets. On the demo board, an NE1617ADS temperature monitor IC converts the input voltage into a readable temperature value. The NE1617ADS has an internal sensor and one interface towards an external temperature sensor. In the application, the temperature of three drain pads must be measured independently via the single input of NE1617ADS. Therefore three separate sensors are required. A selection circuit chooses then one of the three load path FETs.

On [Figure 6](#) the FETs Q1, Q3 and Q5 (NX3008NBKT in SOT416 package) can select one sensor out of three. The corresponding selection signals are generated by the microcontroller IC2. The temperature data of the NE1617ADS is read by the microcontroller. The temperature measured in the center of the pad is calculated towards the solder-point temperature  $T_{sp}$ . A specific correction factor was defined based on infrared photographs taken from the board.

The software of the demo PCB has 5 states or modes. These modes can be toggled with the center push-button SW1. The first mode is the reset status. In this mode, a ticker message appears on the display and no output is active. After button SW1 is pushed, the LCD display shows the message 'All Off'. In the next states, the three load switch stages are activated, starting with the SO-8 (SOT96), followed by the DFN3333-8 (SOT873-1) and finally the DFN2020MD-6 stage. The last 4 states (All Off, SO-8, DFN3333, DFN2020) are circling around if the button is pushed further. In the states where an output is activated,  $T_{sp}$  of the chosen channel is displayed in the second row of the LCD display. The right button on the PCB (SW2) is a reset button and puts the hardware into the reset state. A MAX811-T voltage monitor (manufactured by Maxim Integrated) generates a reset pulse whenever the supply of the microcontroller falls below a critical level. It also removes bouncing of the signal from the reset button.



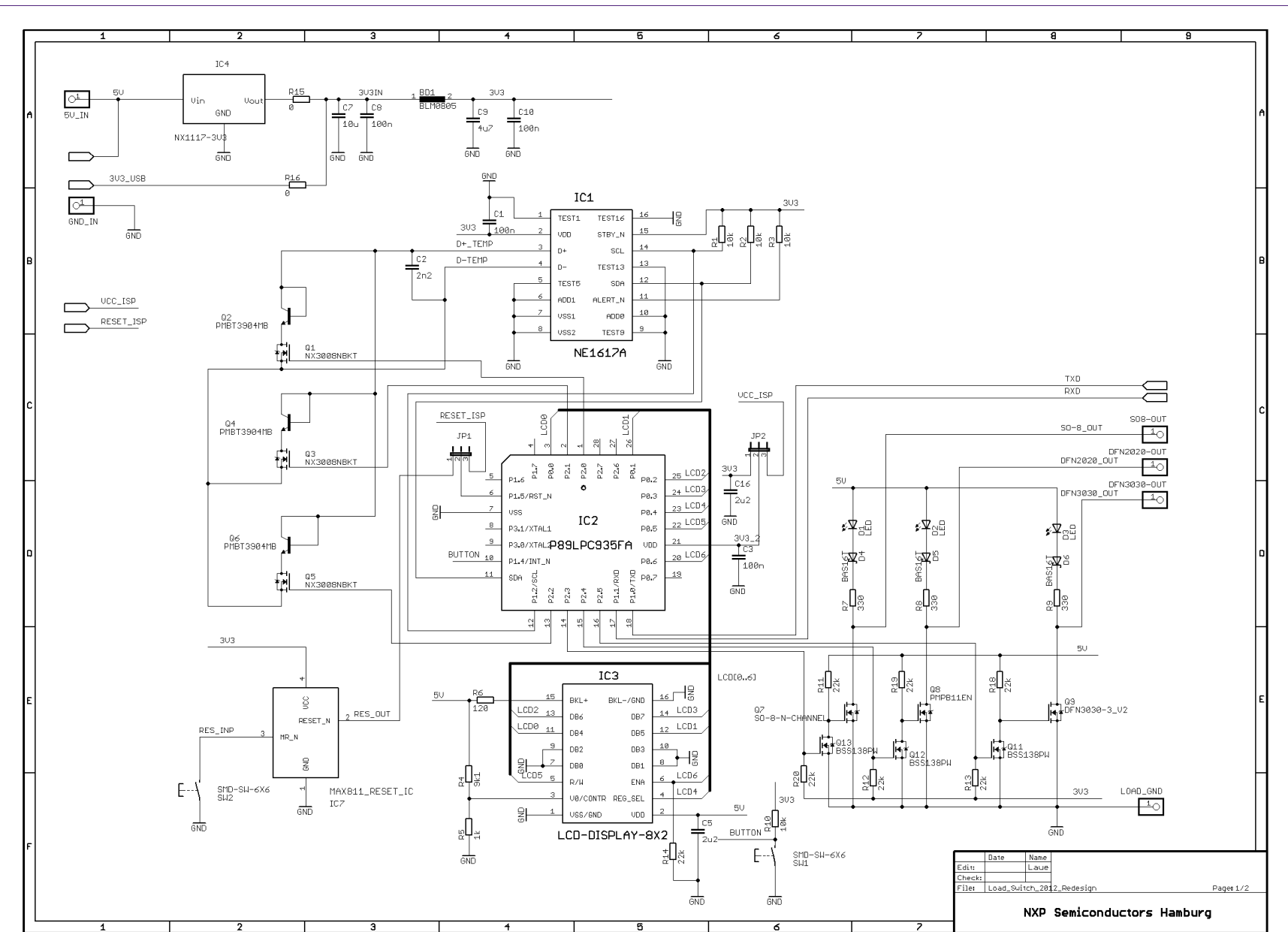

Date	Name
Editt:	L. aue
Check:	
FlDer:	Load_Switch_2012_Redesign

Pages 1/2

NXP Semiconductors Hamburg

Fig 6. Circuit diagram load switch demo PCB part 1: load switches, microcontroller, temperature measurement

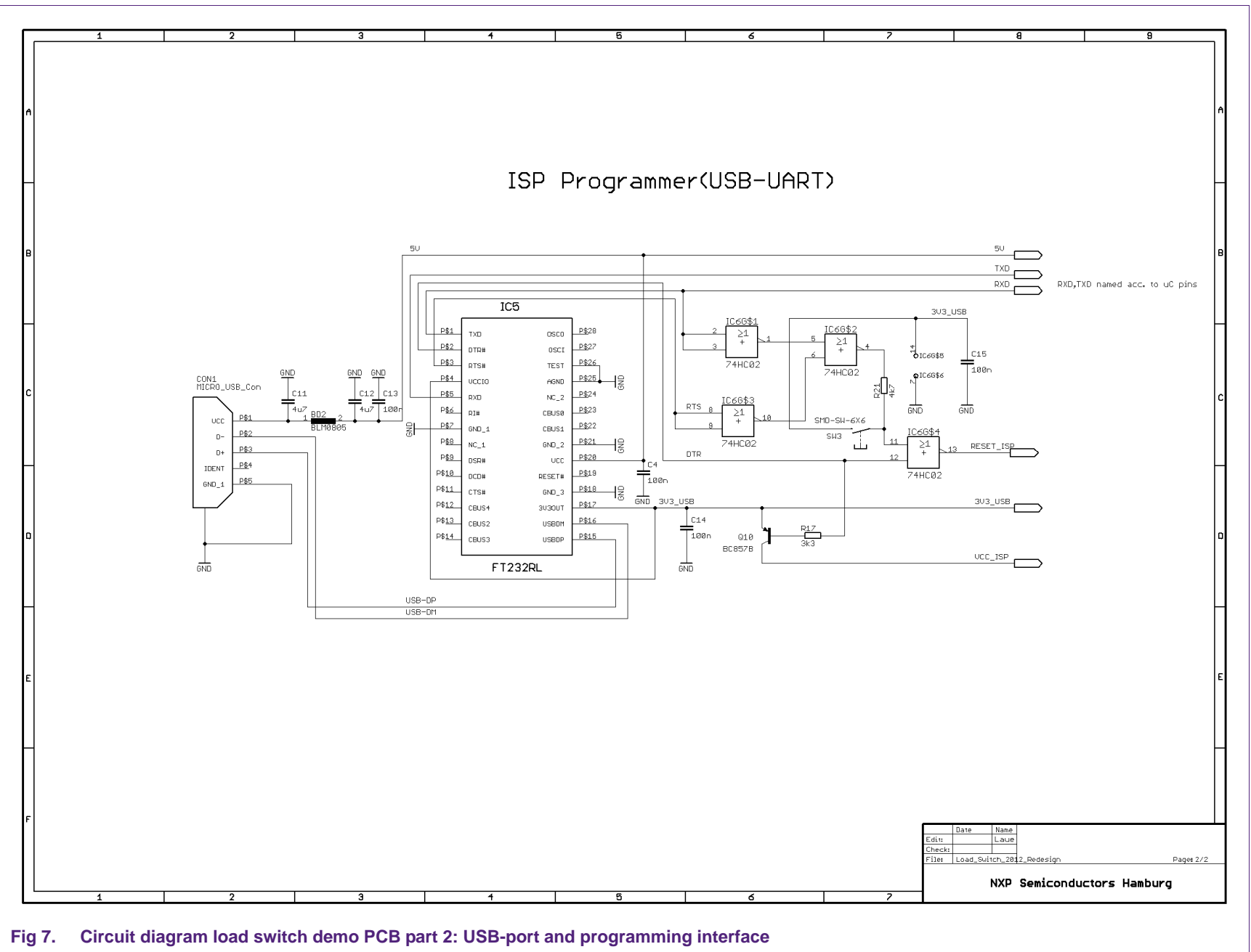

Fig 7. Circuit diagram load switch demo PCB part 2: USB-port and programming interface

The demo board does not need any specific power supply. An external connection micro-USB is sufficient. The 5 V supply from the USB connector powers the microcontroller P89LPC935, the NE1617ADS, the LCD display with its LED backlight and the USB to serial Universal Asynchronous Receiver and Transmitter (UART) interface circuit FT232RL (manufactured by Future Technology Devices International Ltd.).

From the 5 V-USB a 3.3 V supply can either be generated by a NX1117C33Z LDO or via an integrated LDO in the FT232RL. The desired path can be chosen via the assembly of R15 or R16.

The P89LPC935 microcontroller can be programmed easily on the board. [Figure 7](#) shows the schematic diagram with the USB port and the interface chip FT232RL. For flashing of the microcontroller, both jumpers (JP1 and JP2) have to be located in the upper position in order to put the hardware into the In-System Programming (ISP) mode. Afterwards a new software can be flashed using for example, the NXP Semiconductors freeware programming tool 'Flash Magic' ([Ref. 1 "AN11248"](#)) which can be downloaded from the Internet. After flashing, the jumpers must be put back into the lower position (away from the display). [Figure 8](#) shows the placement of the components on the PCB.

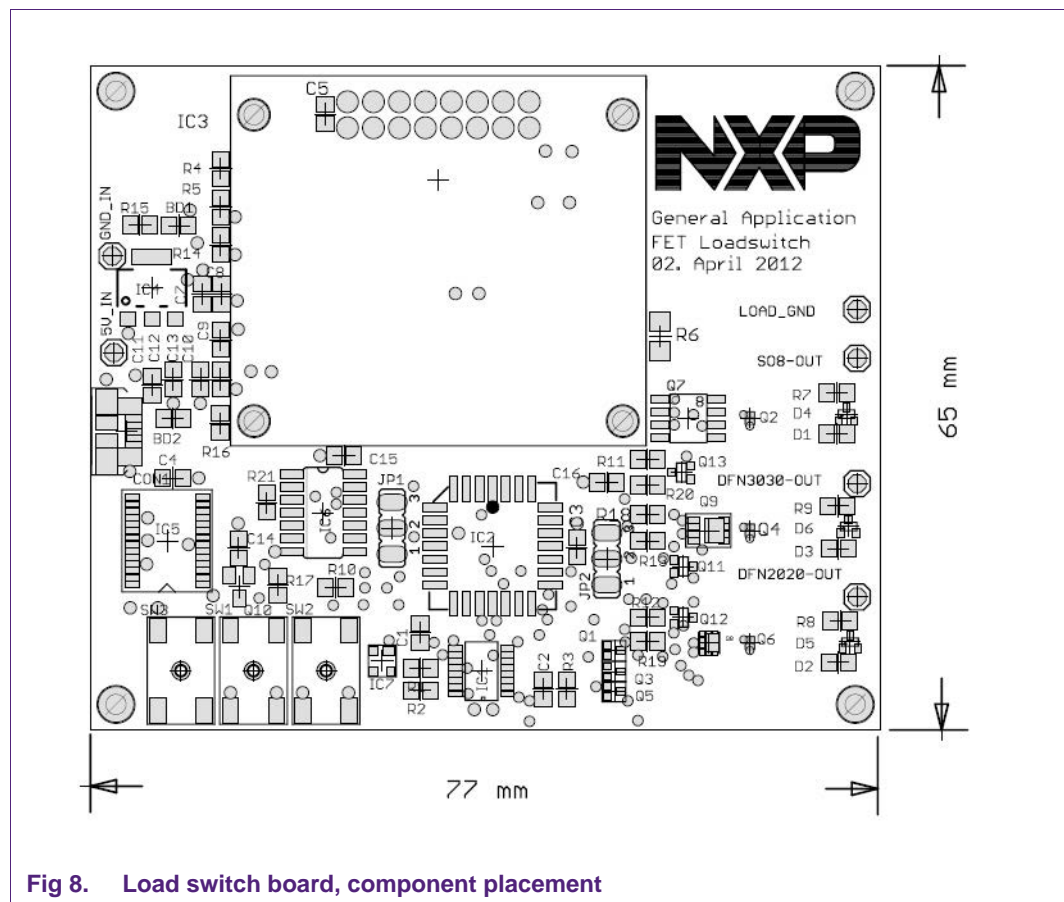

Fig 8. Load switch board, component placement

### 3.2 MOSFET portfolio in DFN2020 suitable for load switching

[Table 1](#) shows an overview of the NXP Semiconductors single P-channel MOSFETs in the DFN2020MD-6 (SOT1220) package. Types can be provided with a maximum  $V_{DS}$  rating of 30 V, 20 V and 12 V. Furthermore a gate specification with a maximum  $V_{GS}$  of  $\pm 12$  V and  $\pm 20$  V can be supported. For switching of lower input voltages, the products with the lower  $V_{GS}$  limits are recommended because of the lower gate-source voltage threshold. The lowest  $R_{DSon}$  value is typically 15 m $\Omega$  for PMPB15XP.

**Table 1. Single P-channel MOSFET in DFN2020MD-6 (SOT1220)**

Type number	Drain-source voltage $V_{DS}$ (V)	Gate-source voltage $V_{GS}$ (V)	Drain-source on-state resistance $R_{DSon}$ (m $\Omega$ ) $V_{GS} = 4.5$ V		Gate-source threshold voltage $V_{GS(th)}$ (V) $I_D = 250 \mu A; V_{DS} = V_{GS}$			ESD protection <a href="#">[1]</a>
			Typ	Max	Min	Typ	Max	
PMPB15XP	-12	$\pm 12$	15	19	-0.47	-0.68	-0.9	-
PMPB19XP	-20	$\pm 12$	19	22.5	-0.47	-0.68	-0.9	-
PMPB33XP	-20	$\pm 12$	30	37	-0.47	-0.68	-0.9	-
PMPB47XP	-30	$\pm 12$	47	58	-0.47	-0.68	-0.9	-
PMPB27EP	-30	$\pm 20$	32	43	-1	-1.5	-2.5	-
PMPB48EP	-30	$\pm 20$	55	76	-1	-1.5	-2.5	-
PMPB20XPE	-20	$\pm 12$	19	23.5	-0.47	-0.68	-0.9	2.4 kV
PMPB29XPE	-20	$\pm 12$	28	32.5	-0.47	-0.68	-0.9	2.3 kV
PMPB43XPE	-20	$\pm 12$	39	48	-0.47	-0.68	-0.9	2.3 kV

[1] ESD: ElectroStatic Discharge

[Table 2](#) shows the list of available N-channel MOSFETs in DFN2020MD-6 (SOT1220). The  $V_{DS}$  maximum ratings range from 60 V to 20 V. The PMPB10XNE provides an  $R_{DSon}$  of 10 m $\Omega$  only at  $V_{GS} = 4.5$  V.

**Table 2. Single N-channel MOSFET in DFN2020MD-6 (SOT1220)**

Type number	Drain-source voltage $V_{DS}$ (V)	Gate-source voltage $V_{GS}$ (V)	Drain-source on-state resistance $R_{DSon}$ (m $\Omega$ ) $V_{GS} = 4.5$ V		Gate-source threshold voltage $V_{GS(th)}$ (V) $I_D = 250 \mu A; V_{DS} = V_{GS}$			ESD protection
			Typ	Max	Min	Typ	Max	
PMPB40SNA	60	$\pm 16$	40	50	1	1.7	3	-
PMPB11EN	30	$\pm 20$	14	16.5	1	1.5	2	-
PMPB20EN	30	$\pm 20$	20.5	24.5	1	1.5	2	-
PMPB16XN	30	$\pm 12$	16	21	0.5	1	1.5	-
PMPB33XN	30	$\pm 12$	37	47	0.45	0.8	1.2	-
PMPB15XN	20	$\pm 12$	18	21	0.4	0.65	0.9	-
PMPB12UN	20	$\pm 8$	14	18	0.4	0.7	1	-
PMPB20UN	20	$\pm 8$	19	25	0.4	0.7	1	-
PMPB13XNE	30	$\pm 12$	13	16	0.4	0.65	0.9	2.2 kV
PMPB29XNE	30	$\pm 12$	28	33	0.4	0.65	0.9	2.1 kV
PMPB10XNE	20	$\pm 12$	10	14	0.4	0.65	0.9	2.2 kV
PMPB23XNE	20	$\pm 12$	19	22	0.4	0.65	0.9	2.1 kV

In many cases load switches are supposed to provide a reverse protection. It is the case for charger applications where the battery shall not be able to drive back a current towards the charger input plug. Other common use cases are switches for AC loads, where the switch must be in a high impedance condition for both polarities across the deactivated switch. As already depicted in [Figure 2](#), MOSFETs do not provide a reverse blocking due to the inherent body diode. This problem can be solved by using two MOSFETs in a so-called back-to-back configuration; see [Figure 9](#).

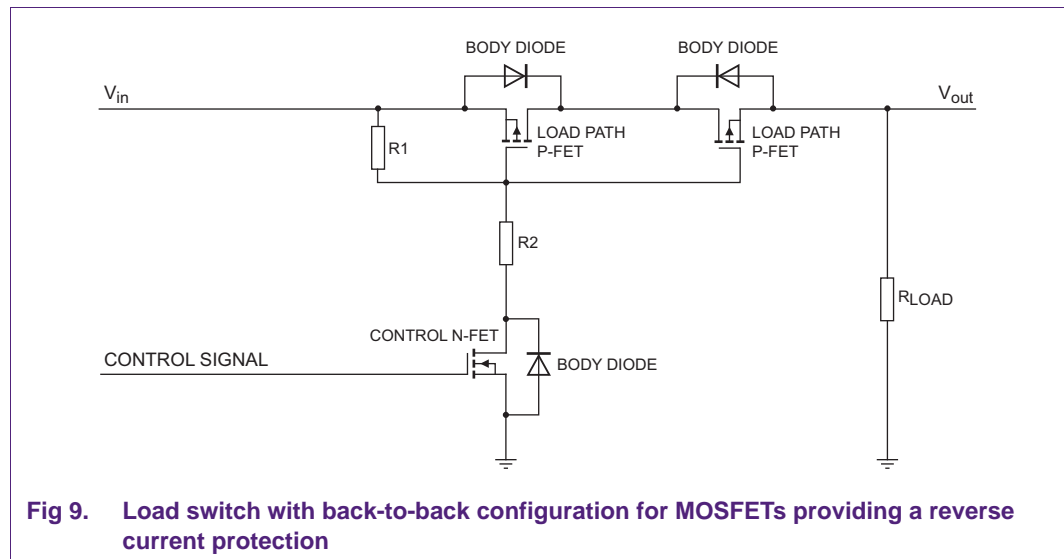

If the thermal requirements and  $R_{DSon}$  requirements advice such a design, the back-to-back configuration can be realized using two single MOSFETs in separate packages. However NXP Semiconductors offers a large variety of dual MOSFETs in  $2\text{ mm} \times 2\text{ mm}$  packages. They allow a very compact realization of a reverse current protected load switch. [Table 3](#) shows a list of these products.

**Table 3. Dual MOSFET in DFN2020-6 (SOT1118)**

Type Name	Configuration	Polarity	Drain-source voltage $V_{DS}$ (V)	Gate-source voltage $V_{GS}$ (V)	Drain-source on-state resistance $R_{DSon}$ (m $\Omega$ ) $V_{GS} = 4.5\text{ V}$		ESD protection
					Typ	Max	
PMDPB58UPE	dual	P-channel	-20	$\pm 8$	58	67	2.0 kV
PMDPB70XPE	dual	P-channel	-20	$\pm 12$	66	79	2.0 kV
PMDPB85UPE	dual	P-channel	-20	$\pm 8$	82	103	2.0 kV
PMDPB55XP	dual	P-channel	-20	$\pm 12$	55	70	-
PMDPB70XP	dual	P-channel	-30	$\pm 12$	70	87	-
PMDPB80XP	dual	P-channel	-20	$\pm 12$	80	102	-
PMDPB38UNE	dual	N-channel	20	$\pm 8$	38	46	1.6 kV
PMDPB95XNE	dual	N-channel	30	$\pm 12$	95	120	1.8 kV
PMDPB28UN	dual	N-channel	20	$\pm 8$	30	37	-
PMDPB30XN	dual	N-channel	20	$\pm 12$	32	40	-
PMDPB42UN	dual	N-channel	20	$\pm 8$	40	50	-
PMDPB56XN	dual	N-channel	30	$\pm 12$	55	73	-

Table 3. Dual MOSFET in DFN2020-6 (SOT1118) ...continued

Type Name	Configuration	Polarity	Drain-source voltage $V_{DS}$ (V)	Gate-source voltage $V_{GS}$ (V)	Drain-source on-state resistance $R_{DSon}$ (m $\Omega$ ) $V_{GS} = 4.5$ V		ESD protection
					Typ	Max	
PMDPB70EN	dual	N-channel	30	$\pm 20$	67	88	-
PMCPB5530X	complementary	P-channel	-20	$\pm 12$	55	70	-
		N-channel	20	$\pm 12$	26	34	-
PMFPB8032XP	MOSFET + Schottky diode	P-channel	-20	$\pm 12$	80	102	-
PMFPB8040XP	MOSFET + Schottky diode	P-channel	-20	$\pm 12$	80	102	-
PMC85XP	MOSFET + RET transistor	P-channel	-30	$\pm 12$	85	110	-

### 3.3 Thermal performance results for the demo board

The PMPB11EN is assembled as DFN2020MD-6 (SOT1220) type on the NXP demo PCB. The crystal of this MOSFET was assembled into a DFN3333-8 (SOT873-1) and SO-8 (SOT96) package. The MOSFETs in the larger packages are no commercial types and have been produced for a realistic comparison, where identical dies are tested in different packages.

Figure 10, Figure 11 and Figure 12 show photographs of the demo PCB. They display the temperature after the activated load switch FET had reached its final temperature. Test conditions ensure that no airflow can influence the results.



For the 6 A load current the temperature difference between the three packages was roughly 10 °C from the biggest towards the smallest package.



$I_{load} = 6\text{ A}$

Fig 11. Test with DFN3333-8 (SOT873-1) package



$I_{load} = 6\text{ A}$

Fig 12. Test with DFN2020MD-6 (SOT1220) package

The demo PCB uses 1 cm<sup>2</sup> drain pads for each MOSFET. The PCB is a standard FR4 board and the copper-layer thickness is 35 μm only. [Figure 13](#) shows an infrared image of the area around the DFN2020MD-6 (SOT1220) MOSFET. The rather high temperature gradient on the drain pad becomes obvious, because the thin copper cannot conduct the heat away like a thicker copper layer of for example, 70 μm. The 70 μm board technology is often used for MOSFET specification boards.

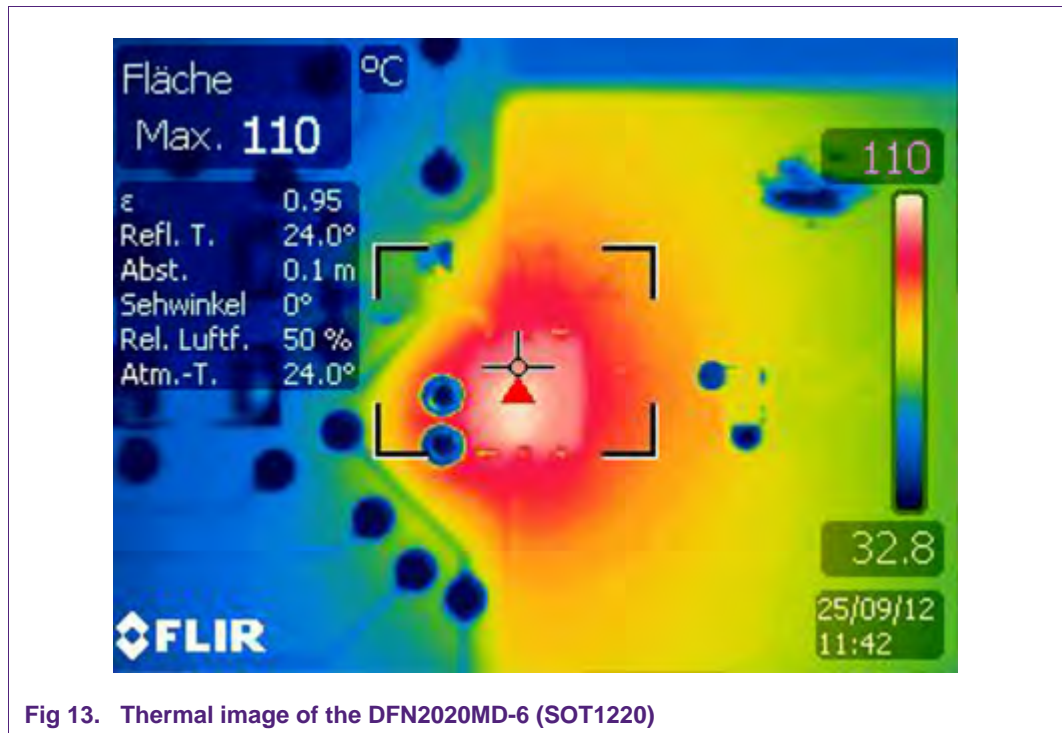

Fig 13. Thermal image of the DFN2020MD-6 (SOT1220)

## 4. High-power density with MOSFETs in DFN packages

### 4.1 DFN2020MD-6 (SOT1220) MOSFETs in comparison to DFN3333-8 (SOT873-1) and SO-8 (SOT96)

NXP Semiconductors DFN packages allow handling comparably high power in a small package with a small mounting area. [Figure 14](#) shows this fact in a very compelling way. The mounting area is of about 30 mm<sup>2</sup> for a SO-8 (SOT96), 10 mm<sup>2</sup> for a DFN3333-8 (SOT873-1) and 4 mm<sup>2</sup> for a DFN2020MD-6 (SOT1220). The power density of the DFN2020MD-6 (SOT1220) exceeds the values of the other packages with 425 mW/mm<sup>2</sup> versus 190 mW/mm<sup>2</sup> for the DFN3333-8 (SOT873-1) and 60 mW/mm<sup>2</sup> for the SO-8 (SOT96) package. The power density values are based on the total power dissipation  $P_{tot}$  as specified in the data sheets for a 6 cm<sup>2</sup> drain pad at  $T_{amb} = 25\text{ °C}$ . The power density value of 425 mW/mm<sup>2</sup> results of  $P_{tot} = 1.7\text{ W}$  divided by 4 mm<sup>2</sup>.



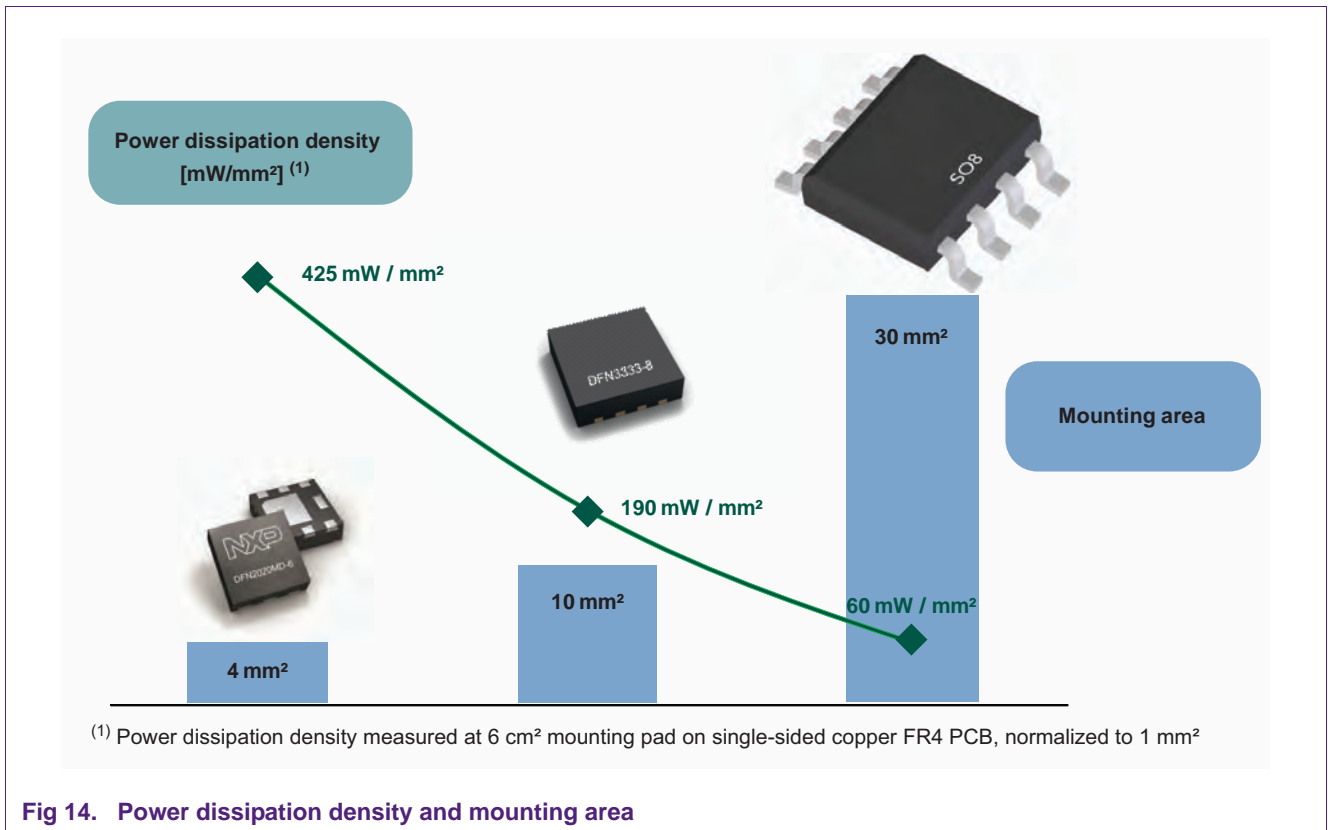

Fig 14. Power dissipation density and mounting area

#### 4.2 DFN1006 packages provide a good thermal performance in smaller sizes

NXP Semiconductors MOSFETs in DFN packages outperform conventional packages in many aspects. Larger dies allow a lower  $R_{DS(on)}$  for a similar mounting area. The good thermal coupling of the comparably large drain pad to the PCB allows dissipating the heat in an optimal way.

Figure 15 shows a comparison of 2 MOSFETs in SOT416 against the corresponding product in a DFN1006 package. The mounting area of a DFN1006 package is significantly smaller with 1.17 mm² versus 4.4 mm² for the recommended footprints. Although the DFN1006 types require less PCB space, they can support higher maximum drain currents due to the good thermal performance of the DFN packages. These facts are even more obvious when the DFN1006 package is compared to a leaded SOT1208 package which is quite popular for small commodity FETs.

NXP Semiconductors constantly develops a growing portfolio of MOSFETs. Next steps are 1.0 mm × 1.0 mm and 1.6 mm × 1.6 mm products.

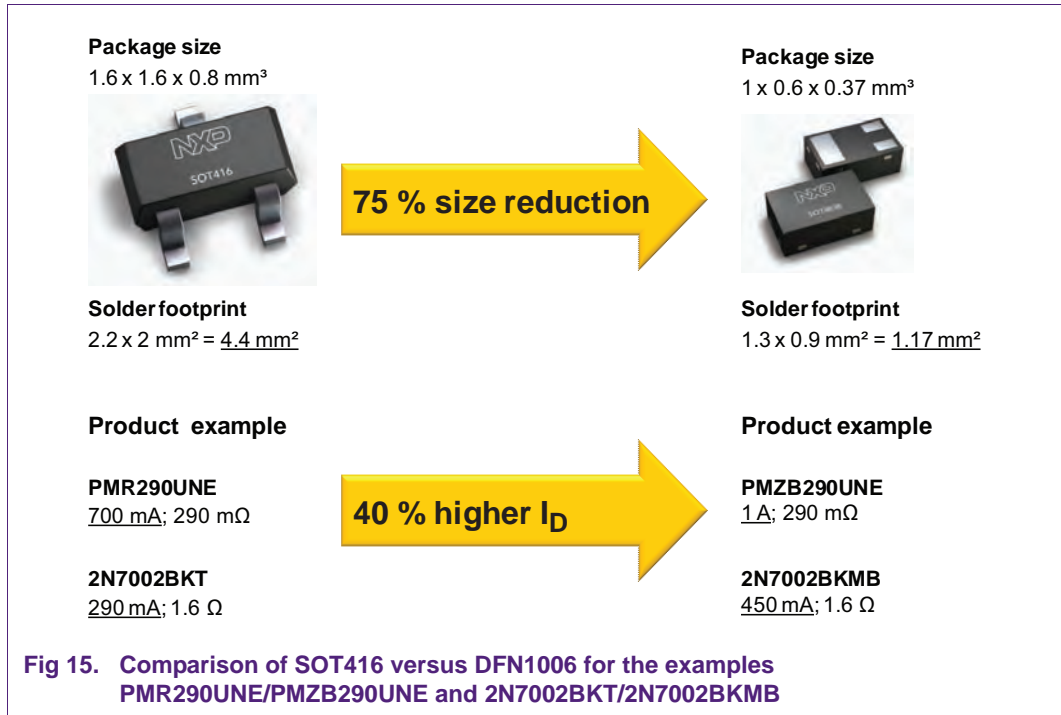

## 5. Summary

NXP Semiconductors DFN2020MD-6 (SOT1220) single and DFN2020-6 (SOT1118) dual MOSFETs allow more compact designs because of their good electrical and thermal performance. With their increased power density, more power can be handled on a small mounting area. In modern electronic designs like ultralight PCs, tablet PCs and smartphones, space constraints are getting more tough. As these applications are all battery-driven, energy efficiency is also an important selection criterion.

The demo PCB described in this document proves that NXP Semiconductors small DFN package DFN2020MD-6 (SOT1220) can often replace bigger components in DFN3333-8 (SOT873-1) or in SO-8 (SOT96) package.

## 6. Appendix

The appendix gives further information about the load switch demo PCB. [Figure 16](#) shows the place plan with the component values. [Figure 17](#) depicts the top layer of the board.

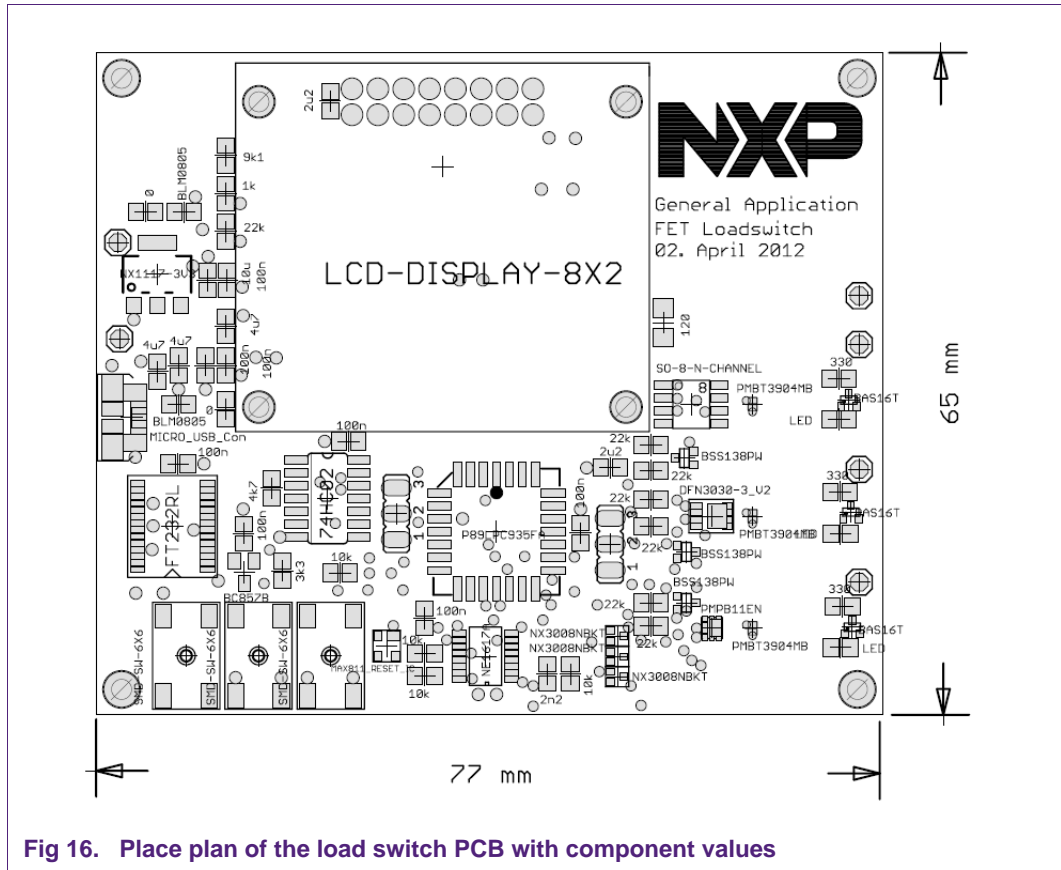
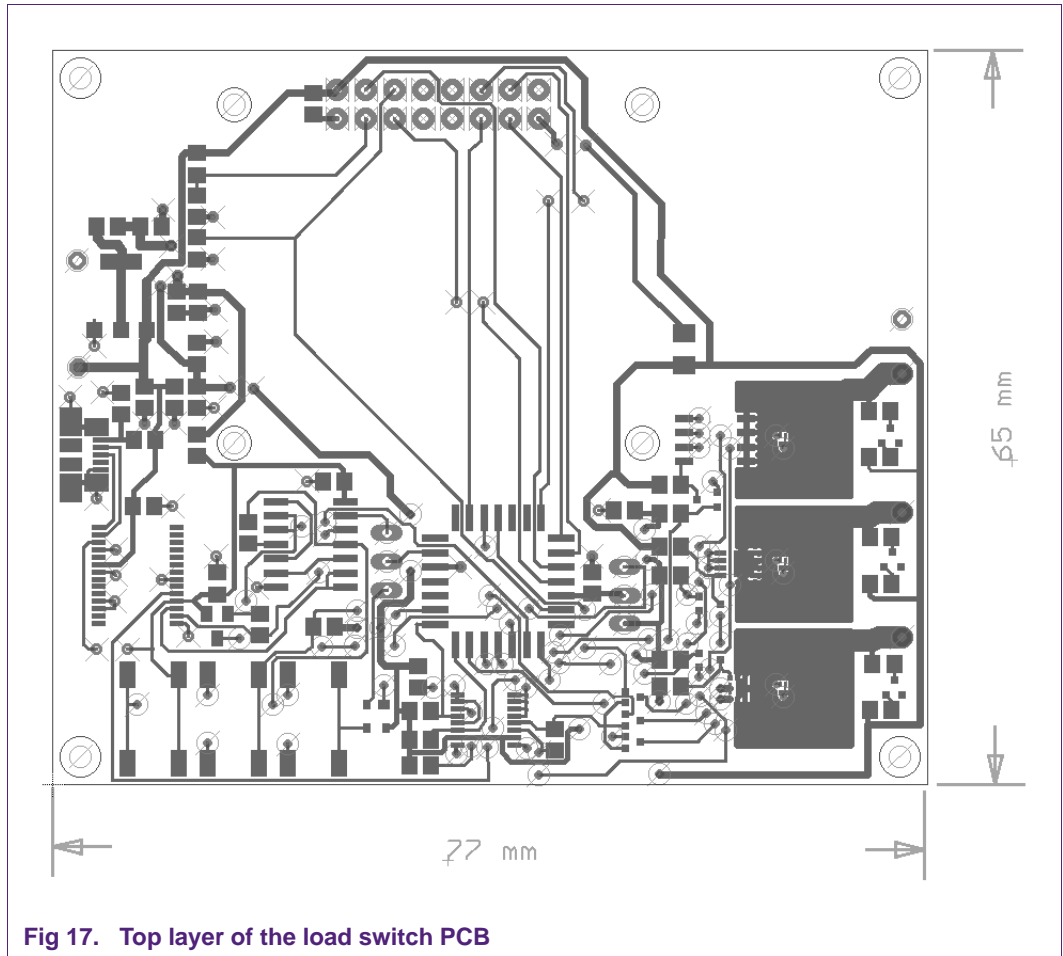

Fig 16. Place plan of the load switch PCB with component values



## 7. References

- [1] AN11248 — In-System Programming of LPC18xx/43xx flash

## 8. Legal information

### 8.1 Definitions

**Draft** — The document is a draft version only. The content is still under internal review and subject to formal approval, which may result in modifications or additions. NXP Semiconductors does not give any representations or warranties as to the accuracy or completeness of information included herein and shall have no liability for the consequences of use of such information.

### 8.2 Disclaimers

**Limited warranty and liability** — Information in this document is believed to be accurate and reliable. However, NXP Semiconductors does not give any representations or warranties, expressed or implied, as to the accuracy or completeness of such information and shall have no liability for the consequences of use of such information. NXP Semiconductors takes no responsibility for the content in this document if provided by an information source outside of NXP Semiconductors.

In no event shall NXP Semiconductors be liable for any indirect, incidental, punitive, special or consequential damages (including - without limitation - lost profits, lost savings, business interruption, costs related to the removal or replacement of any products or rework charges) whether or not such damages are based on tort (including negligence), warranty, breach of contract or any other legal theory.

Notwithstanding any damages that customer might incur for any reason whatsoever, NXP Semiconductors' aggregate and cumulative liability towards customer for the products described herein shall be limited in accordance with the *Terms and conditions of commercial sale* of NXP Semiconductors.

**Right to make changes** — NXP Semiconductors reserves the right to make changes to information published in this document, including without limitation specifications and product descriptions, at any time and without notice. This document supersedes and replaces all information supplied prior to the publication hereof.

**Suitability for use** — NXP Semiconductors products are not designed, authorized or warranted to be suitable for use in life support, life-critical or safety-critical systems or equipment, nor in applications where failure or malfunction of an NXP Semiconductors product can reasonably be expected to result in personal injury, death or severe property or environmental damage. NXP Semiconductors and its suppliers accept no liability for inclusion and/or use of NXP Semiconductors products in such equipment or applications and therefore such inclusion and/or use is at the customer's own risk.

**Applications** — Applications that are described herein for any of these products are for illustrative purposes only. NXP Semiconductors makes no representation or warranty that such applications will be suitable for the specified use without further testing or modification.

Customers are responsible for the design and operation of their applications and products using NXP Semiconductors products, and NXP Semiconductors accepts no liability for any assistance with applications or customer product design. It is customer's sole responsibility to determine whether the NXP Semiconductors product is suitable and fit for the customer's applications and products planned, as well as for the planned application and use of customer's third party customer(s). Customers should provide appropriate design and operating safeguards to minimize the risks associated with their applications and products.

NXP Semiconductors does not accept any liability related to any default, damage, costs or problem which is based on any weakness or default in the customer's applications or products, or the application or use by customer's third party customer(s). Customer is responsible for doing all necessary testing for the customer's applications and products using NXP Semiconductors products in order to avoid a default of the applications and the products or of the application or use by customer's third party customer(s). NXP does not accept any liability in this respect.

**Export control** — This document as well as the item(s) described herein may be subject to export control regulations. Export might require a prior authorization from competent authorities.

**Evaluation products** — This product is provided on an "as is" and "with all faults" basis for evaluation purposes only. NXP Semiconductors, its affiliates and their suppliers expressly disclaim all warranties, whether express, implied or statutory, including but not limited to the implied warranties of non-infringement, merchantability and fitness for a particular purpose. The entire risk as to the quality, or arising out of the use or performance, of this product remains with customer.

In no event shall NXP Semiconductors, its affiliates or their suppliers be liable to customer for any special, indirect, consequential, punitive or incidental damages (including without limitation damages for loss of business, business interruption, loss of use, loss of data or information, and the like) arising out of the use of or inability to use the product, whether or not based on tort (including negligence), strict liability, breach of contract, breach of warranty or any other theory, even if advised of the possibility of such damages.

Notwithstanding any damages that customer might incur for any reason whatsoever (including without limitation, all damages referenced above and all direct or general damages), the entire liability of NXP Semiconductors, its affiliates and their suppliers and customer's exclusive remedy for all of the foregoing shall be limited to actual damages incurred by customer based on reasonable reliance up to the greater of the amount actually paid by customer for the product or five dollars (US\$5.00). The foregoing limitations, exclusions and disclaimers shall apply to the maximum extent permitted by applicable law, even if any remedy fails of its essential purpose.

### 8.3 Trademarks

Notice: All referenced brands, product names, service names and trademarks are the property of their respective owners.

9. Contents

1 Introduction ..... 3

2 Load switch topologies..... 3

2.1 High-side switch ..... 3

2.2 Low-side switch ..... 6

3 Demonstration PCB for the evaluation of the thermal performance of MOSFETs in DFN2020, DFN3333 and SO-8..... 6

3.1 Hardware of the demonstration PCB ..... 6

3.2 MOSFET portfolio in DFN2020 suitable for load switching..... 11

3.3 Thermal performance results for the demo board ..... 13

4 High-power density with MOSFETs in DFN packages..... 15

4.1 DFN2020MD-6 (SOT1220) MOSFETs in comparison to DFN3333-8 (SOT873-1) and SO-8 (SOT96) ..... 15

4.2 DFN1006 packages provide a good thermal performance in smaller sizes ..... 16

5 Summary ..... 17

6 Appendix ..... 18

7 References ..... 19

8 Legal information..... 20

8.1 Definitions..... 20

8.2 Disclaimers..... 20

8.3 Trademarks..... 20

9 Contents ..... 21

Please be aware that important notices concerning this document and the product(s) described herein, have been included in section 'Legal information'.

© NXP B.V. 2013.

All rights reserved.

For more information, please visit: <http://www.nxp.com>

For sales office addresses, please send an email to: [salesaddresses@nxp.com](mailto:salesaddresses@nxp.com)

Date of release: 25 January 2013

Document identifier: AN11304