

How battery micro-measurements can eliminate range anxiety



Understanding EV Battery Management Systems

It is clear that the automotive industry is taking the steps necessary to move away from its dependency on fossil-fuels as a plethora of electric and hybrid platforms and vehicles are announced for launch in the next decade starting in 2020. Government-led initiatives are starting to take effect pushing down from the top, while grass-roots activists are highlighting the damage of climate change from the bottom, changing perceptions in the wider public consciousness.



Sales of electric vehicles (EV) and hybrid electrics (HEV) are predicted to surpass those of traditional purely Internal Combustion Engine (ICE) powertrain-enabled vehicles by 2038, while achieving cost parity a decade or more earlier. In addition to public transport, such as busses, construction vehicles, trucks, motorbikes and bicycles are also being electrified. Today, around 90% of all electric busses in operation are in China.

Much of the challenge around the EV and the electrical part of the high-voltage (HV) design is in the powertrain. Here, advancements in power devices, including silicon carbide (SiC), along with innovations in power topologies mean that delivering energy to electric motors is highly efficient. Charging (piles) stations for electric vehicles also benefit from >97% efficiencies while delivering fast charge capabilities of up to 350 kW in an attempt to compete timewise with refueling at the gas station. It is in the batteries, however, where significant room for improvement lies. Part of this is to do with the composition of the battery cells themselves, an area that has seen leaps and bounds improvements in energy density in the past decade. The other part lies with the management of the energy in those cells when formed into the power delivery system at the heart of the EV: the battery pack.

Why the BMS is so important for EVs

One of the concerns most often raised as hindering the move to an EV is range anxiety. This is a two-part issue. The first is the range provided by the vehicle's battery. Typically, even low-range EVs cover the average daily commute comfortably, but the realities of life mean that the range can be perceived as limited when unexpected additional trips or detours are factored in. If we're honest, fossil-fuel drivers suffer range anxiety too as the needle dips into the red. However, this leads us to the area where the EV driver's anxiety is really focused: charging infrastructure. This is the second issue, making sure that 'energy' can be topped-up as easily as fossil-fuel vehicles today. Plenty of infrastructure is fine but, unless it provides close to a full charge in a timeframe similar to a full tank of fuel, this is an impediment to mobility.

The vehicle's battery management system (BMS) is at the heart of this challenge and has the potential to significantly reduce both aspects of range anxiety.

An EV battery is composed of a large number of individual cells, typically based upon a Lithium Ion (Li-ion) chemistry today. Every cell operates at between 2.5 and 4.2 V so they are linked in series, to provide higher voltages of up to 800 V, as well as in parallel, to deliver the power required to bring a vehicle in motion. The cells are constructed into packs, while packs together form the final battery. A single battery can contain upwards of 7000 individual cells.

What makes up a typical battery? What are the challenges for a BMS?

The BMS is responsible for taking care of every single cell in the battery, ensuring that, as far as possible, the charge and discharge of each cell remains equal. It is perhaps a sign of the maturity of BMSs in general that no automotive OEM seems to have settled on a single architecture or approach, with them still being more or less customized to each platform where they are integrated.

Ideally, neither the pack nor cell should attain 100% or 0% charge, so the BMS needs to maintain the charge in an, admittedly wide, Goldilocks zone. Over time, after each cell has experienced many charge and discharge cycles, some cells may start to show signs of weakness. The optimal BMS needs to compensate for this in such a way that neighboring cells can continue to operate at their full potential, while the weaker cells contribute as best they can.

Lithium in isolation is highly reactive and flammable, and has the potential to cause serious damage if mistreated. The BMS is therefore also responsible for carefully monitoring cell temperature during use and charging, and cutting the flow of energy should temperature limits be reached.

Another key function of the BMS is its fuel gauge capability. Just like in a fossil fuel vehicle, the amount of energy coming in and going out has to be carefully monitored, providing the driver with as realistic an assessment as possible of the remaining or available range. This requires accurate current measurement that can also track the erratic load changes that occur in this application.

Finally, it should be noted that the battery system, due to the enormous energy it contains and damage it could cause, along with the high voltages involved, is considered a safety risk. Assessments are needed to ensure the system fulfils ASIL-D requirements, the highest automotive safety integrity level.

A BMS will typically consist of different devices, among which the most relevant are: a battery management chip that monitors the cells, the temperature, and energy flow; and a microcontroller (MCU) that undertakes the analysis and communicates with the remaining automotive system. Both of these devices demand very high levels of reliability and quality, and should be sourced from suppliers with a pedigree in the automotive industry.

The architecture of the battery management chip is critical in ensuring that the driver receives reliable information on charge status, as well as attaining optimal driving range at any time over the battery's lifetime. This starts with the cell measurement circuitry that provides synchronous high-accuracy voltage measurements. This data then forms the basis for coulomb counting, the information that provides charge status and an estimate of remaining range. Despite the vehicle's ignition being off, the system must stay active, monitoring the natural degradation in charge as the vehicle sits idle or is being charged.



The device also has to provide interfaces for temperature monitoring, typically implemented through carefully placed negative temperature coefficient (NTC) thermistors. Having carefully monitored the individual cells, the device should also support an approach to balancing, a way of distributing energy equally across the cells. A single battery monitoring solution can typically handle a handful of cells but, as already mentioned, a complete battery pack may consist of several thousand. This demands that a communication interface is made available that is capable of spanning the hundreds of volts between the cells at the top and bottom end of the system.

One critical element to review is the approach to safety, since the cell monitoring will be rated at ASIL-D. This demands that there is a suitable built-in self-test (BIST) strategy and fault detection system, while redundancy should also be included to ensure that there is a way of handling most potential failure-modes during operation.

To support the monitoring and data-sharing with the remainder of the vehicle's systems, a competent microcontroller platform is needed. Despite the seemingly simple task, the device needs to deliver a level of performance able to handle the quantity of data and analysis, along with the execution of an AUTOSAR software solution. This will require features that also support the fulfilment of ASIL-D criteria, such as a lockstep CPU, BIST, cyclic redundancy check (CRC) unit, and error checking with reporting for the memory block.

Often overlooked, but worth investigating, it is beneficial reviewing if a hardware trace port is also available to support both debugging and testing in conjunction with suitable embedded development tools.

Tackling the challenges of cell monitoring

The cell module forms the smallest element of the entire battery pack handling the status of up to 14 cells. Undertaking the monitoring are devices such as the L9963 from STMicroelectronics, an application-specific standard product (ASSP) targeting battery management applications (Figure 1). Each L9963 can measure up to 14 Lithium cells using a 16-bit sigma-delta ADC.

An external shunt resistor operates together with an integrated current sense amplifier (CSA) to monitor current flow, perform coulomb counting, and detect faults.

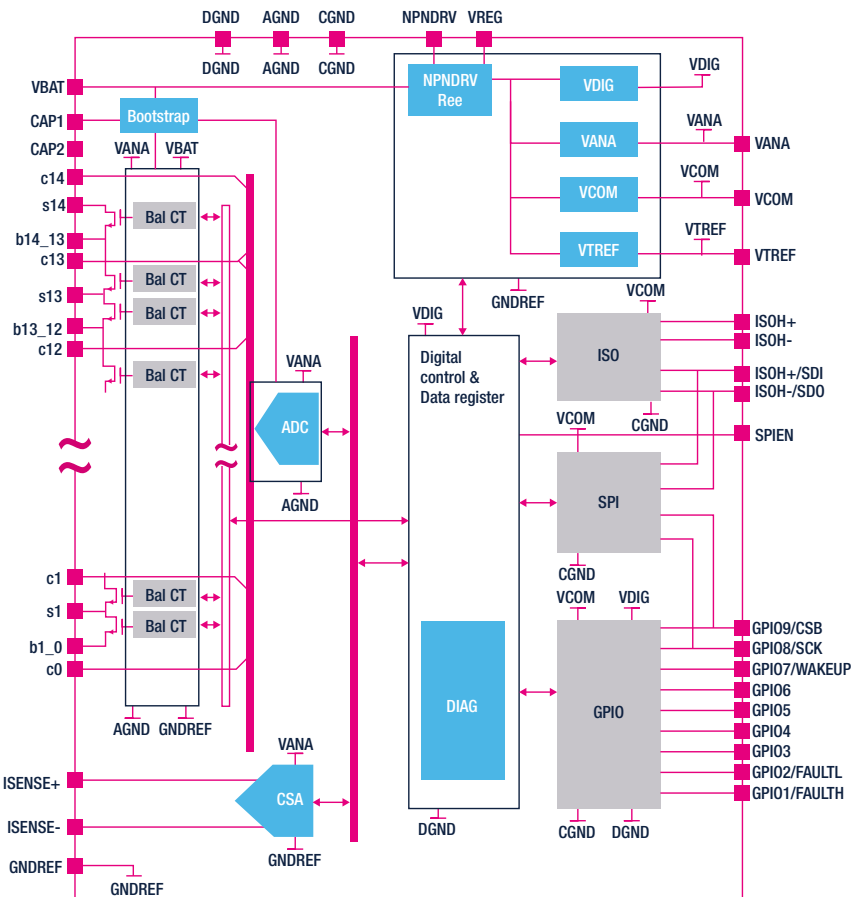

Figure 1: The L9963 block diagram with its main core blocks.

This synchronicity of measurement is essential in order to attain the highest quality battery status and is made possible thanks to the 16-bit integrated ADC completing the conversions in just 300 μ s. In addition to the synchronous measurement, the accuracy of ± 2 mV over a temperature range of -40 to +125°C contributes further to the overall quality of the final battery pack. Cell voltages can lie anywhere in the 1.7 to 4.7 V range.

In order to fulfill ASIL-D requirements in compliance with the ISO 26262 standard, the L9963 integrates a fully redundant cell measurement path.

Cell balancing is a critical function and two modes are supported. In the first mode, balancing occurs under the control of the host MCU. Alternatively, a timed mode allows balancing to be executed for a time period written to a counter internal to the L9963. Currents of up to 200 mA are supported for passive cell balancing through the internal FETs, and higher currents could be contemplated by utilizing external FETs if desired.

To support temperature monitoring, up to seven NTC thermistors can be attached to the device, the measurements of which are packaged up with the cell and coulomb data recorded by the ADCs. A handful of additional pins provide configurable general-purpose I/Os. Two integrated 5 V regulator outputs provide the necessary power for any additional circuitry.

In order for the entire battery pack to be managed safely, it is essential that the measurement data is extracted quickly to the MCU for analysis. A single module monitoring solution can be controlled via a standard SPI interface. However, in a battery pack, each cell monitoring system must operate electrically isolated from its neighboring devices. In such cases the SPI communication is implemented via isolation transformers or capacitors.

Multiple L9963s can be linked in a daisy-chain or loop configuration that ensures reliable high-speed data transmission and low EMI over long distances. The SPI interface provides access to a wide range of fault detection and notification functions, ensuring that the final solution can fulfill safety standard requirements. Experiments with fifteen L9963s in a chain have shown that a latency of under 2 μ s between the first and last device once the conversion command has been issued. In addition, 96 cells in a system of 8 L9963s can convert and report their results inside 4 ms.

In order to simplify interfacing the chosen MCU with the daisy-chained L9963s, a transceiver chip is planned, known as the L9963T, that provides the necessary link between the MCUs logic-level SPI and the first transformer or capacitors in the chain (Figure 2).

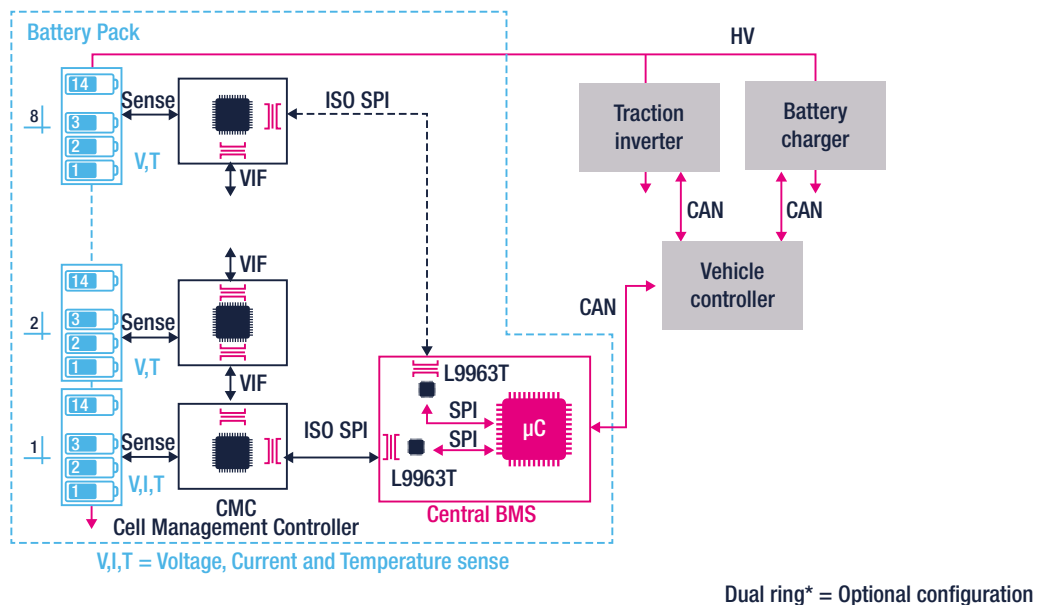

Figure 2: Combined with the L9963T, the selected MCU can communicate with every battery module in the system, acquiring data from eight L9963s in 4 ms.

One of the key differences between a battery management application and other applications is that it cannot be powered down, since the power source, the cells, are part of the application. This hot-plugging challenge can be a serious issue and is commonly tackled by including Zener diodes parallel to each cell. Thanks to the robust implementation of the L9963, the system design engineer can eliminate these components and further reduce costs.

Maintaining the system overview at all times

With functional safety at the forefront of any BMS design, the team needs to carefully consider their MCU choice. Once the modules have been architected, the selected MCU needs to provide a high-level of reliability, demanding that it includes self-testing and redundancy. An AUTOSAR-compliant package of software, from real-time operating system (RTOS) to drivers and software stacks, is essential. Lastly, development tools should be selected that are capable of providing advanced insights, such as displaying the state of the RTOS, and tracing code execution and memory accesses.

The overall architecture of the BMS also needs consideration. In order to provide a level of scalability it makes sense to use one MCU per battery module of a few tens or hundreds of cells, with a larger MCU taking responsibility for control of the pack as a whole. This breaks the solution into a Cell Monitoring Controller (CMC) for modules, and a Battery Monitoring Controller (BMC) at pack level (Figure 3).

Here, STMicroelectronics' SPC5 series of high-performance, safety-critical MCUs provide the optimal mix of technology, performance, reliability, and scalability across the family offering.

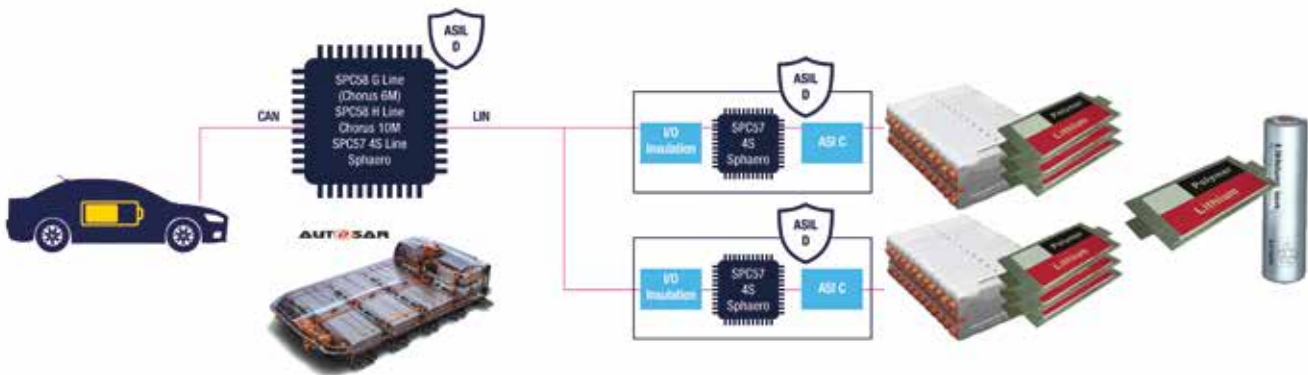

Figure 3: The ASIL-D capable SPC58 and SPC57 series are the ideal MCU companion throughout the BMS application.

For the CMC, the SPC570S and SPC574S series of performance MCUs are ideal, offering advanced timers, sigma-delta ADCs that complement the L9963 where required, and support for high-temperature operation. Both MCUs are single-core devices utilizing the e200z0 PowerArchitecture™ CPU in the case of the SPC570S (80 MHz), or the e200z4d in the case of the SPC574S (140 MHz).

The SPC570S delivers four 6-channel timers, two 16-channel ADCs, and two FlexCAN interfaces that, compared to traditional CAN, provide a more deterministic behavior and increased reliability. The MCU also provides up to 512 Kbytes of Flash memory and 48 Kbytes of RAM. A total of three DSPI interfaces (Deserial Serial Peripheral Interface) provide enough scope for interfacing with the L9963.

The SPC574S is offered with up to 1.5 Mbytes of Flash memory and 128 Kbytes of RAM. It replaces the SPC570S's FlexCAN with two CAN-FD interfaces and more richly featured ADCs. Both MCUs are ASIL-D SEooC (Safety Element out of Context) capable, offered in a 100-pin QFP package, and can operate from 40 to +150°C. They also provide a further significant range of peripherals and interfaces that are attractive in the context of automotive applications.

For the BMC, a more advanced MCU solution is demanded, thanks to the oversight function it plays in the system and due to the high quantity of data that must be processed. Here the SPC58 G Line and SPC58 H Line are worthy solutions (Figure 4), although the SPC574S can also be considered here in simpler implementations.

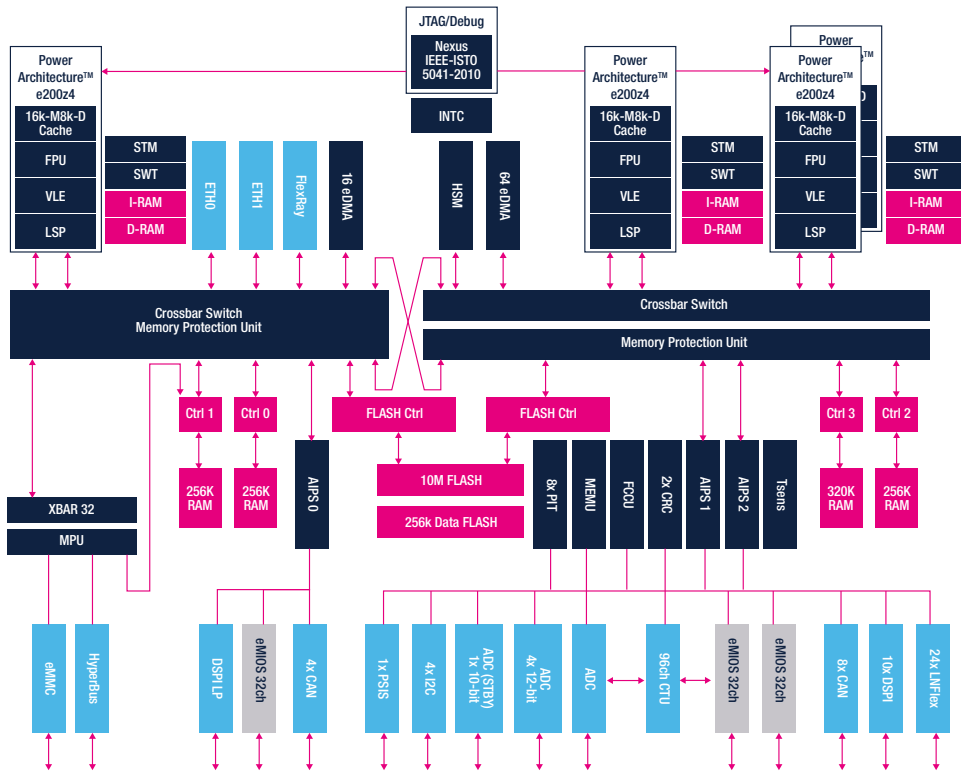

Figure 4: The SPC58 H line delivers serious processing performance and memory, security, a range of automotive peripherals, and support for over-the-air updates.

The SPC58 G and H line MCUs are STMicroelectronics' highest performance, general-purpose automotive devices, featuring a high number of communication interfaces, and low power support for moments where the application is idling. The BMC can make use of the successive-approximation-register (SAR) ADCs for accurate system temperature monitoring, while the CAN and Ethernet interfaces enable integration into today's and future E/E Architectures. Security, and the potential for hacking future connected cars, is handled by a Hardware Security Module (HSM) and boot power analysis hardware on the G line. The H line also additionally includes hardware accelerators for both symmetric and asymmetric algorithms, allowing applications using it to attain the full EVITA vehicle intrusion protection level.

Featuring triple e200z4 cores operating at up to 200 MHz, with an optional lock-step core on both devices, along with up to 10 Mbytes of Flash memory, these MCUs are more than capable of fulfilling the demands of central responsibility for a BMS. With the connected car on the horizon, these MCUs also support secure Over-The-Air (OTA) firmware updates, and inevitable trend of increasingly electronic vehicles (Figure 5).

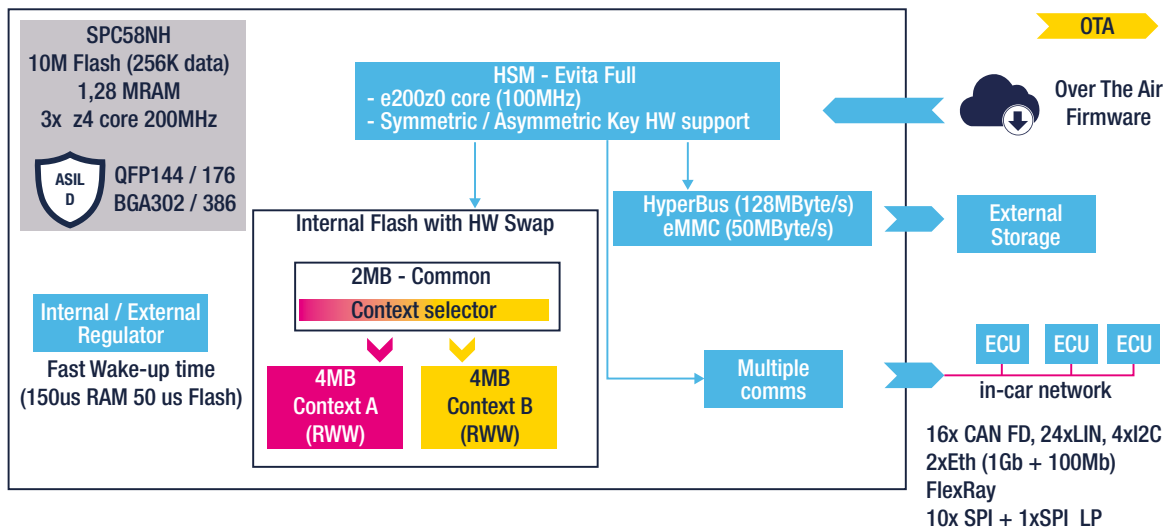

Figure 5: Secure OTA with full EVITA compliance is possible with the SPC58 H line.

The energy management capability of an EV's BMS is, ultimately, core to the vehicle's success on the market, impacting range, reliability, and the usable lifetime of the battery pack. As a complete system, it is exceptionally challenging, requiring minute attention to detail, managing coulombs of energy of single cells, while also maintaining the macro view of the entire system, both the battery and that which it is supplying. STMicroelectronics' pedigree in automotive applications forms the basis for several highly-competent silicon solutions for the BMS; the L9963 and L9963T for cell management, and the SPC57 and SPC58 MCUs for monitoring, control and delivery. In addition, these silicon solutions are underpinned by a range of development boards, software packages, and reference designs to support engineering across the entire development process.

