

CliQ III DIN Rail Power Supply

24V 120W 1 Phase / DRP-24V120W1C□N



Highlights & Features

- Universal AC input voltage range
- Built-in constant current circuit for charging application
- High efficiency of up to 91% at 230Vac
- Power Boost of 150% for 5 seconds
- Advanced Power Boost (APB) of 200% for 50ms
- SEMI F47 compliance at 120Vac
- Extreme low temperature cold start at -40°C
- Built-in DC OK Contact and LED indicator for DC OK
- Conformal coating on PCBA to protect against common dust and chemical pollutants

Safety Standards



CB Certified for worldwide use

Model Number:	DRP-24V120W1C□N
Unit Weight:	0.85 kg (1.87 lb)
Dimensions (L x W x D):	124 x 60 x 117 mm (4.88 x 2.36 x 4.61 inch)

General Description

The CliQ III series of DIN rail power supply series is designed with high power density and intelligent overload protection features. All the models in the series are encased in rugged yet lightweight and full corrosion resistant aluminium casing. The single output with universal input design offers overcurrent protection in constant current mode which makes the series suitable for charging application. Like the rest of the CliQ family of products, conformal coating is applied on the PCBAs to protect against common dust and chemical pollutant often found in harsh industrial environment. Delta CliQ III DIN rail power supply series features built-in Power Boost of 150% for 5 seconds. Such feature enables reserve power to be always available for reliable startup of loads with high inrush current without the need of a more expensive power supply at higher power rating.

Model Information

CliQ III DIN Rail Power Supply

Model Number	Input Voltage Range	Rated Output Voltage	Rated Output Current
DRP-24V120W1C□N	88-264Vac	24Vdc	5.0A

Model Numbering

DR	P –	24V	120W	1	C	□	N
DIN Rail	Power Supply	Output Voltage	Output Power	Single Phase	CliQ III	Input Voltage A – AC Input B – AC & DC Input	N – Metal Case, without Class I, Div 2 and ATEX approvals

CliQ III DIN Rail Power Supply

24V 120W 1 Phase / DRP-24V120W1C□N

Specifications

Input Ratings / Characteristics

Nominal Input Voltage		100-240Vac		Applicable for TN-, TT and IT mains networks
Input Voltage Range		100-264Vac		Continuously operating
		88-100Vac		With power de-rating. Refer to Fig. 6 on page 11.
Input Frequency	Nom.	50-60Hz		Range: 47-63Hz
DC Input Voltage Range		100-375Vdc		Continuously operating, with safety approval according to IEC/EN/UL 60950-1.
		88-100Vdc		With power de-rating. Refer to Fig. 7 on page 11.
		115Vac	230Vac	
Input Current	Typ.	1.18A	0.61A	At 24V, 5A. Refer to Fig. 1 on page 3.
	Max.	1.40A	0.70A	At 24V, 5A.
Efficiency	Typ.	89.92%	91.49%	At 24V, 5A. Refer to Fig. 2 on page 3.
	Min.	89.50%	91.00%	At 24V, 5A.
Average Efficiency	Typ.	87.92%	88.37%	At 24V, 1.25A (25%), 2.5A (50%),
	Min.	87.00%	88.00%	3.75A (75%), 5.0A (100%)
Max Power Dissipation	Typ.	3.31W	3.20W	At 24V, 0A. Refer to Fig. 3 on page 3.
	Max.	5.0W	5.0W	At 24V, 0A.
	Typ.	13.46W	11.16W	At 24V, 5A. Refer to Fig. 3 on page 3.
	Max.	14.0W	13.0W	At 24V, 5A.
Max Inrush Current (Cold Start)	Typ.	31.6A	66.0A	Entire operating temperature range
	Max.	35A	70A	
Max Inrush Energy (Cold Start)	Max.	1A ² s		
Power Factor	Typ.	0.98	0.95	At 24V, 5A. Refer to Fig. 4 on page 3.
	Min.	0.96	0.93	At 24V, 5A.
Leakage Current (Enclosure to Neutral)		< 0.20mA / 0.50mA < 0.24mA / 0.60mA < 0.47mA / 1.20mA		110Vac, 50Hz, TN/TT system / IT system 132Vac, 50Hz, TN/TT system / IT system 264Vac, 50Hz, TN/TT system / IT system

CliQ III DIN Rail Power Supply

24V 120W 1 Phase / DRP-24V120W1C□N

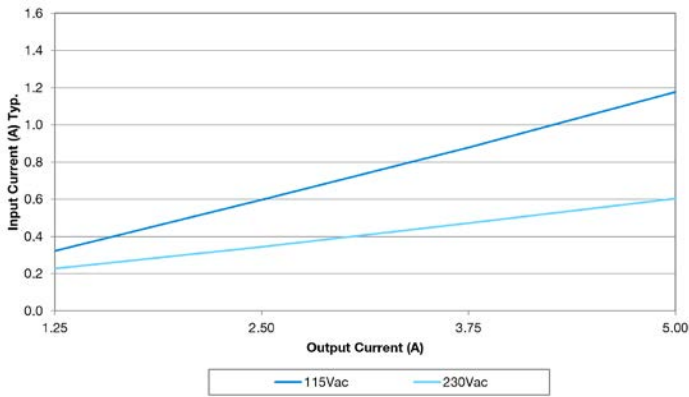

Fig. 1 Input Current VS Output Load at 24V

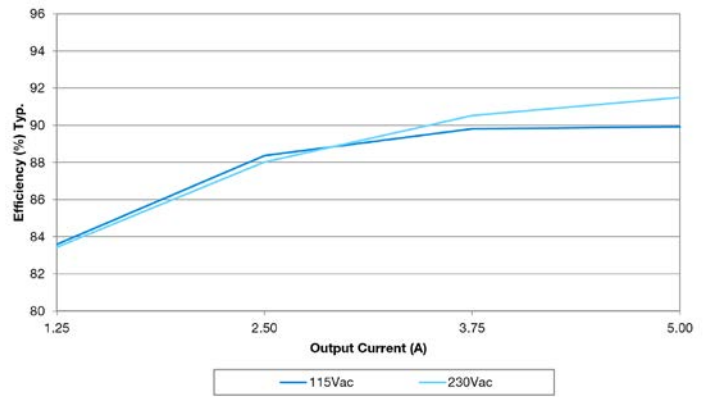

Fig. 2 Efficiency VS Output Load at 24V

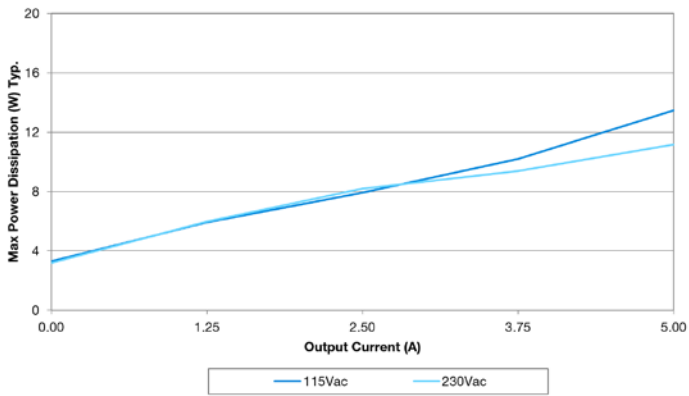

Fig. 3 Max Power Dissipation VS Output Load at 24V

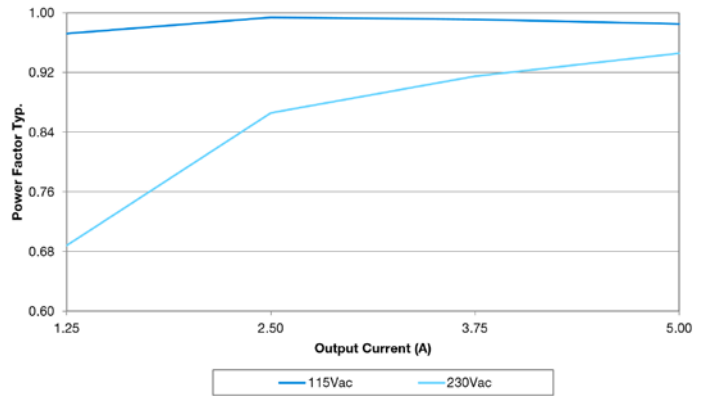

Fig. 4 Power Factor VS Output Load at 24V

CliQ III DIN Rail Power Supply

24V 120W 1 Phase / DRP-24V120W1C□N

Output Ratings / Characteristics*

Nominal Output Voltage		24Vdc	
Factory Set Point Tolerance		24Vdc ± 1.0%	
Output Voltage Adjustment Range		24-28Vdc	
Output Current	Nom. Nom.	0-5.0A / 0-4.28A 7.5A / 6.43A (Slew rate 0.1A/μs)	Continuously operating at 24V / 28V Power Boost for 5 seconds at 24V / 28V, refer to the details in the Function section
Output Power	Nom. Nom.	120W / 120W 180W / 180W	Continuously operating at 24V / 28V Power Boost for 5 seconds at 24V / 28V, refer to the details in the Functions section
Power Boost Duration	Min.	5 seconds	Duration after which output voltage start to droop. Refer to the details in the Function section at Overload & Overcurrent Protections
Power Boost Recovery Time	Typ.	18 seconds	Required wait duration before next Power Boost can be delivered by the power supply. Refer to the details in the Function section
Advanced Power Boost (Slew rate 0.1A/μs)	Typ.	10A @ 50ms, resistive load	Output voltage will drop (Refer to the details in the Function section)
Line Regulation	Max.	0.5% (@ 88-264Vac input, 100% load)	
Load Regulation	Max.	1% (@ 88-264Vac input, 0-100% load)	
PARD**	Max.	100mVpp	20Hz to 20MHz, 50Ω, warm up for 5mins

*For power de-rating, see power de-rating on page 10-11.

**PARD is measured with an AC coupling mode, 5cm wires, and in parallel with 0.1μF ceramic capacitor & 47μF electrolytic capacitor.

		115Vac	230Vac	
Rise Time	Max.	60ms		At 24V, 5A.
Start-up Time	Max.	1500ms		At 24V, 5A.
Hold-up Time	Typ.	35ms		At 24V, 5A.
	Min.	20ms		At 24V, 5A.
Dynamic Response (Overshoot & Undershoot O/P Voltage)	Max.	± 5% @ 0-100% load		Slew rate 0.1A/μs (@ 5Hz, 50Hz & 1kHz, 50% Duty Cycle)
Start-up with Capacitive Loads	Max.	10,000μF		
Functional	DC OK Relay Contact	Rated: 30V at 1A, resistive load. Refer to the details in the Function section at DC OK Relay Contacts and LED Indicator Characteristics on page 14.		

CliQ III DIN Rail Power Supply

24V 120W 1 Phase / DRP-24V120W1C□N

Mechanical

Case Cover / Chassis	Aluminium	
Dimensions (L x W x D)	124 x 40 x 117 mm (4.88 x 1.57 x 4.61 inch)	
Unit Weight	0.58 kg (1.28 lb)	
Indicator	Green LED (DC OK)	
Cooling System	Convection	
Terminal	Input	3 Pins (Rated 600V/35A)
	Output	4 Pins (Rated 300V/28A)
	Signal	2 Pins (Rated 300V/28A)
Wire	Input	AWG 18-8
	Output	AWG 18-12
	Signal	AWG 18-12
Mounting Rail	Standard TS35 DIN Rail in accordance with EN 60715	
Noise (1 Meter from power supply)	Sound Pressure Level (SPL) < 25dBA	

Environment

Surrounding Air Temperature	Operating	-25°C to +70°C (Cold start -40°C)
	Storage	-40°C to +85°C
Power De-rating	Vertical Mounting	> 60°C de-rate power by 2.5% / °C
	Horizontal Mounting	> 40°C de-rate power by 1.67% / °C
	Input Voltage	AC input < 100Vac de-rate power by 0.83% / V DC input < 100Vdc de-rate power by 1.67% / V
Operating Humidity	5 to 95% RH (Non-Condensing)	
Operating Altitude	0 to 5,000 Meters (16,400 ft.)	
Shock Test	Non-Operating	IEC 60068-2-27, Half Sine Wave: 30G for a duration of 18ms; 3 times per direction, 9 times in total
Vibration	Non-Operating	IEC 60068-2-6, Sine Wave: 10-500Hz; 3G peak; displacement of 0.35mm; 60 min per axis for all X, Y, Z directions
Bump Test	Operating	IEC 60068-2-29, Half Sine Wave: 10G for a duration of 11ms, 1,000 times per direction, 6,000 times in total
Over Voltage Category	III (operating altitude 2,500 Meters) II (operating altitude 5,000 Meters)	According to IEC/EN 62477-1 / EN 60204-1 (clearance and creepage distances) and IEC 62103 (safety part)
Pollution Degree	2	

CliQ III DIN Rail Power Supply

24V 120W 1 Phase / DRP-24V120W1C□N

Protections

Overvoltage	28.8 - 35.2V, SELV Output, Hiccup Mode, Non-Latching (Auto-Recovery)	Refer to the details in the Function section
Overload / Overcurrent	125 – 170% of rated load current, Constant current, Hiccup Mode (Auto-Recovery)	Refer to the details in the Function section
Over Temperature	< 80°C Surrounding Air Temperature @ 100% load, Non-Latching (Auto-Recovery)	Refer to the details in the Function section
Short Circuit	Hiccup Mode, Non-Latching (Auto-Recovery when the fault is removed)	Load impedance ≤ 100mOhm, refer to the details in the Function section
Transient Surge Voltage Protection	MOV (Metal Oxide Varistor)	
Internal Fuse at L pin	T3.15A	
Degree of Protection	IP20	
Protection Against Shock	Class I with PE* connection	

*PE: Primary Earth

Reliability Data

MTBF (as per Telcordia SR-332)	1,411,300 hrs.	I/P: 115Vac, O/P: 24V, 5A, Ta: 25°C	
	842,900 hrs.	I/P: 115Vac, O/P: 24V, 5A, Ta: 40°C	
Expected Cap Life Time**	115Vac	230Vac	
	131,400hrs.		O/P: 24V, 5A, Ta: 25°C
	131,400hrs.		O/P: 24V, 2.5A, Ta: 40°C
	21,100hrs.	32,700hrs.	O/P: 24V, 5A, Ta: 60°C
	29,700hrs.	47,300hrs.	O/P: 24V, 3.75A, Ta: 60°C

**Estimated lifetime when 24 hours operating a day and E-cap's manufacturer guarantee at 131,400 hrs. (15 years) as maximum limit of lifetime.

CliQ III DIN Rail Power Supply

24V 120W 1 Phase / DRP-24V120W1C□N

Safety Standards / Directives

Electrical Equipment of Machines		EN 60204-1 (over voltage category III)
Electrical Equipment for Use in Electrical Power Installations		IEC/EN 62477-1 / IEC 62103
Safety Entry Low Voltage		PELV* (EN 60204-1), SELV (EN 60950-1)
Electrical Safety	SIQ Bauart	EN 60950-1
	UL/cUL recognized	UL 60950-1 and CSA C22.2 No. 60950-1 (File No. E191395)
	CB scheme	IEC 60950-1
Industrial Control Equipment	UL/cUL listed	UL 508 and CSA C22.2 No. 107.1-16 (File No. E315355)
CE		In conformance with EMC Directive 2014/30/EU and Low Voltage Directive 2014/35/EU
Material and Parts		RoHS Directive 2011/65/EU Compliant (EN 50581)
Galvanic Isolation	4.0KVac	Input / Output
	2.0KVac	Input / PE
	4.0KVac	Input / DC OK relay contact**
	1.5KVac	Output / PE
	0.5KVac	Output / DC OK relay contact
	1.5KVac	DC OK relay contact / PE
PE Resistance		< 0.1Ohm

*Output must be earthed in the final unit in order to comply with PELV requirements according to standard EN 60204-1.

**Recommend to connect DC OK pins together with output pins.

CliQ III DIN Rail Power Supply

24V 120W 1 Phase / DRP-24V120W1C□N

EMC

Emissions (CE & RE)		Generic Standards: EN 61000-6-3 CISPR 32, EN 55032, CISPR 11, EN 55011, FCC Title 47: Class B		
Component Power Supply for General Use		EN 61204-3		
Immunity		Generic Standards: EN 55024, EN 61000-6-2		
Electrostatic Discharge	IEC 61000-4-2	Level 4 Criteria A ¹⁾ Air Discharge: 15kV Contact Discharge: 8kV		
Radiated Field	IEC 61000-4-3	Level 3 Criteria A ¹⁾ 80MHz-1GHz, 10V/M, 80% modulation (1kHz) 1.4GHz-2GHz, 10V/M, 80% modulation (1KHz) 2GHz-2.7GHz, 10V/M, 80% modulation (1KHz)		
Electrical Fast Transient / Burst	IEC 61000-4-4	Level 4 Criteria A ¹⁾ 4kV		
Surge	IEC 61000-4-5	Level 4 Criteria A ¹⁾ Common Mode ³⁾ : 4kV Differential Mode ⁴⁾ : 2kV		
Conducted	IEC 61000-4-6	Level 3 Criteria A ¹⁾ 150kHz-80MHz, 10Vrms		
Power Frequency Magnetic Fields	IEC 61000-4-8	Criteria A ¹⁾ 30A/Meter		
Voltage Dips and Interruptions	IEC 61000-4-11	0% of 100Vac 40% of 100Vac 70% of 100Vac 0% of 100Vac 0% of 240Vac 40% of 240Vac 70% of 240Vac 0% of 240Vac	0Vac, 20ms 40Vac, 200ms 70Vac, 500ms 0Vac, 5000ms 0Vac, 20ms 40Vac, 200ms 70Vac, 500ms 0Vac, 5000ms	Criteria A ¹⁾ Criteria B ²⁾ Criteria A ¹⁾ Criteria B ²⁾ Criteria A ¹⁾ Criteria A ¹⁾ Criteria A ¹⁾ Criteria B ²⁾
Low Energy Pulse Test (Ring Wave)	IEC 61000-4-12	Level 3 Criteria A ¹⁾ Common Mode ³⁾ : 2kV Differential Mode ⁴⁾ : 1kV		
Harmonic Current Emission	IEC/EN 61000-3-2, Class A			
Voltage Fluctuation and Flicker	IEC/EN 61000-3-3			
Voltage Sag Immunity SEMI F47 – 0706	80% of 120Vac 70% of 120Vac 50% of 120Vac 80% of 200Vac 70% of 200Vac 50% of 200Vac	96Vac, 1000ms 84Vac, 500ms 60Vac, 200ms 160Vac, 1000ms 140Vac, 500ms 100Vac, 200ms	Criteria A ¹⁾ Criteria A ¹⁾ Criteria A ¹⁾ Criteria A ¹⁾ Criteria A ¹⁾ Criteria A ¹⁾	
VDE 0160	Over entire load range	750V, 1.3ms	Criteria A ¹⁾	

1) Criteria A: Normal performance within the specification limits
 2) Criteria B: Temporary degradation or loss of function which is self-recoverable
 3) Asymmetrical: Common mode (Line to earth)
 4) Symmetrical: Differential mode (Line to line)

CliQ III DIN Rail Power Supply

24V 120W 1 Phase / DRP-24V120W1C□N

Block Diagram

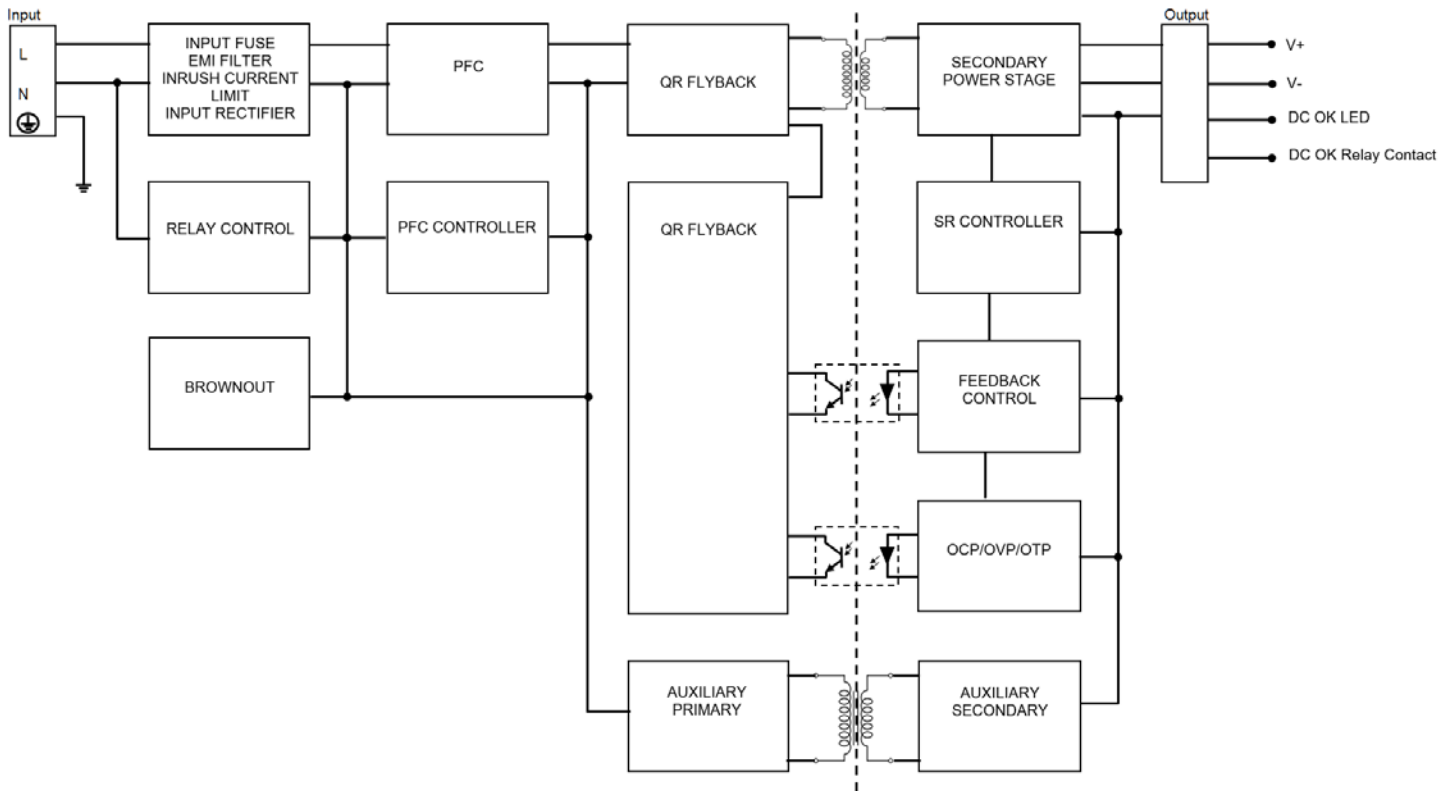

Device Description

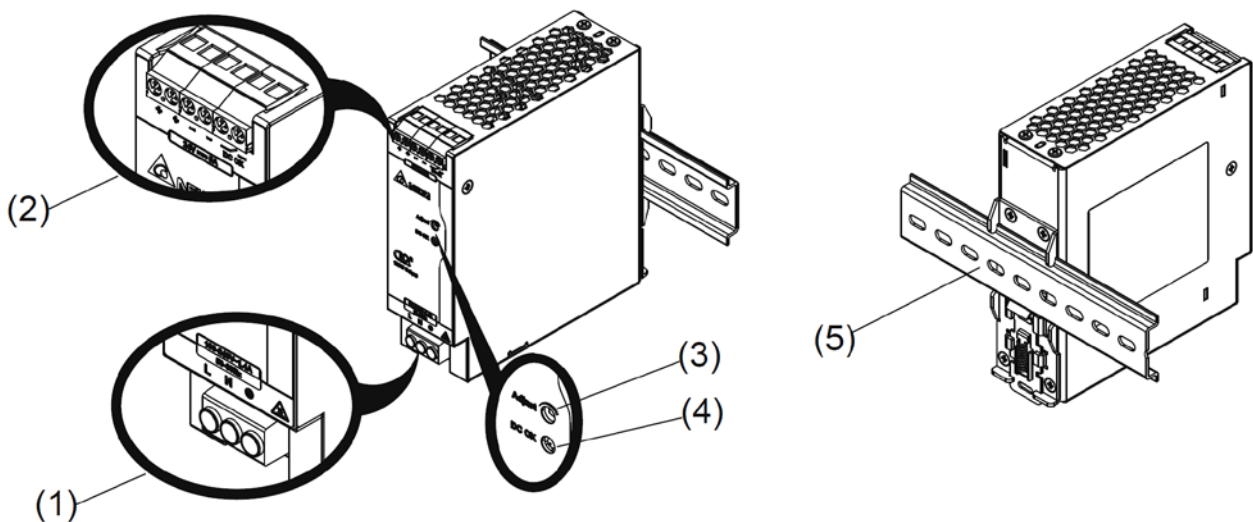

- 1) Input terminal block connector
- 2) Output / Signal terminal block connector
- 3) DC voltage adjustment potentiometer
- 4) DC OK LED (Green)
- 5) Universal mounting rail system

CliQ III DIN Rail Power Supply

24V 120W 1 Phase / DRP-24V120W1C□N

Dimensions

L x W x D: 124 x 40 x 117 mm (4.88 x 1.57 x 4.61 inch)

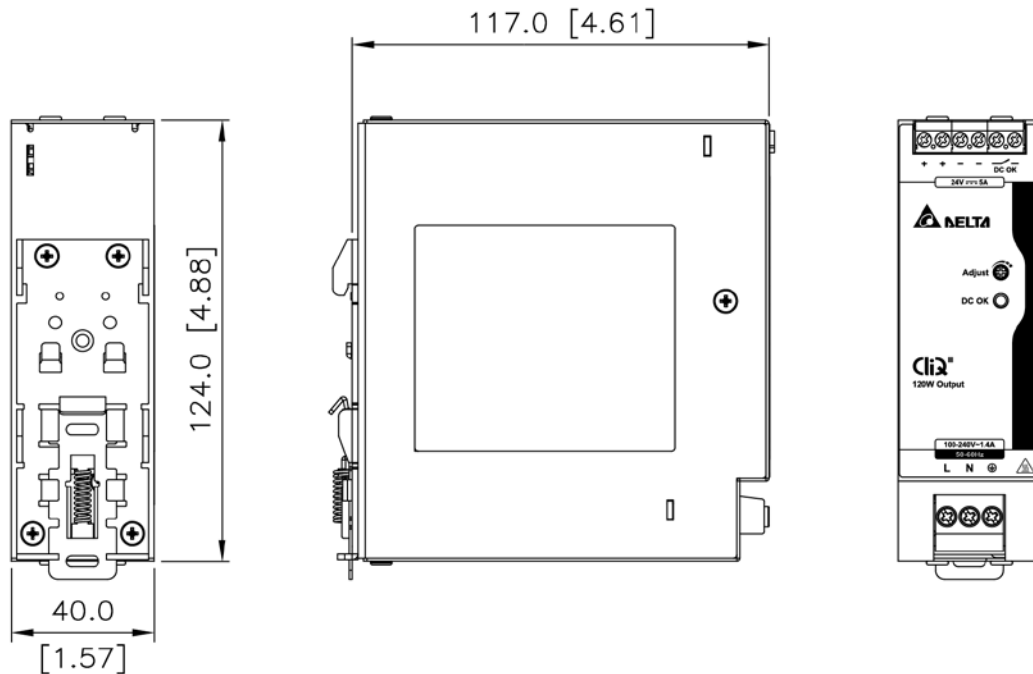

Engineering Data

Output Load De-rating VS Surrounding Air Temperature

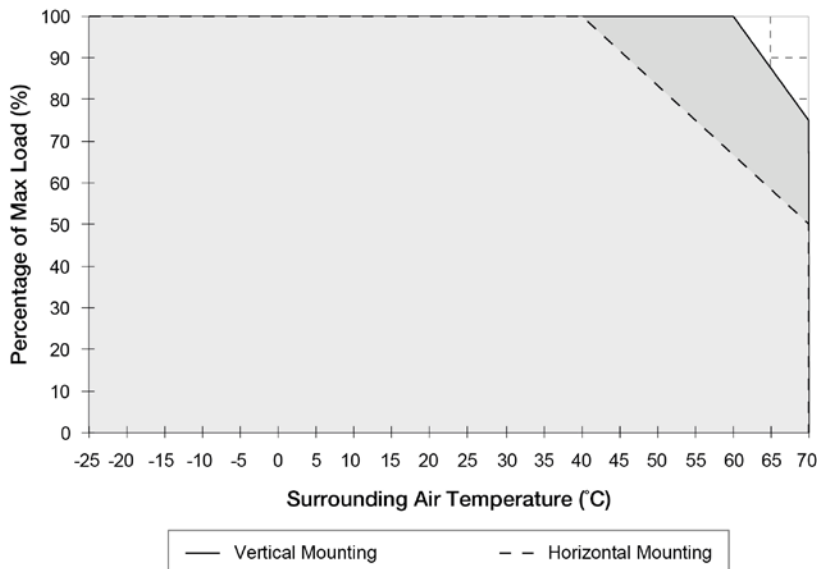

Fig. 5 De-rating for Vertical Mounting Orientation
 > 60°C de-rate power by 2.5% / °C

De-rating for Horizontal Mounting Orientation
 > 40°C de-rate power by 1.67% / °C

Note

1. Power supply components may degrade, or be damaged, when the power supply is continuously used outside the shaded region, refer to the graph shown in Fig. 5.
2. If the output capacity is not reduced when the surrounding air temperature exceeds its specification as defined on Page 5 under "Environment", the device will run into Over Temperature Protection. When activated, the output voltage will go into bouncing mode and will recover when the surrounding air temperature is lowered or the load is reduced as far as necessary to keep the device in working condition.
3. In order for the device to function in the manner intended, it is also necessary to keep a safety distance as recommended in the safety instructions while the device is in operation.
4. Depending on the surrounding air temperature and output load delivered by the power supply, the device can be very hot!
5. If the device has to be mounted in any other orientation, please contact info@deltapsu.com for more details.

CliQ III DIN Rail Power Supply

24V 120W 1 Phase / DRP-24V120W1C□N

Output Load De-rating VS Input Voltage

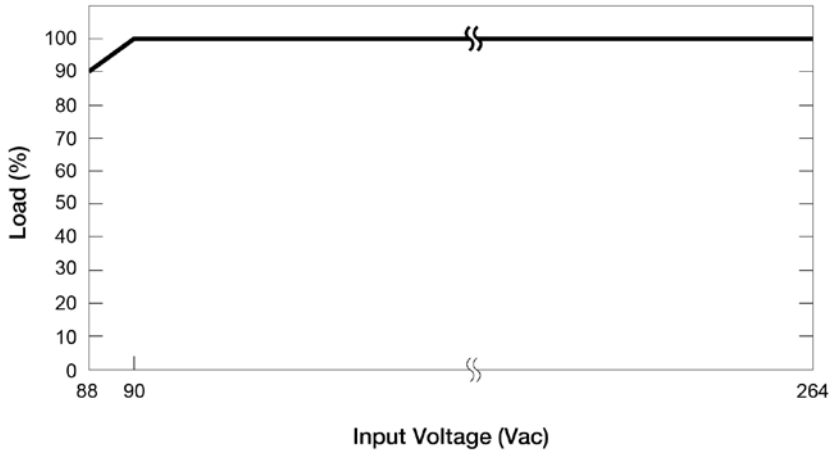

■ Output power de-rating for the AC input voltage range, refer to Fig. 6.

Fig. 6 De-rating for AC input voltage
 < 100Vac de-rate power by 0.83% / V

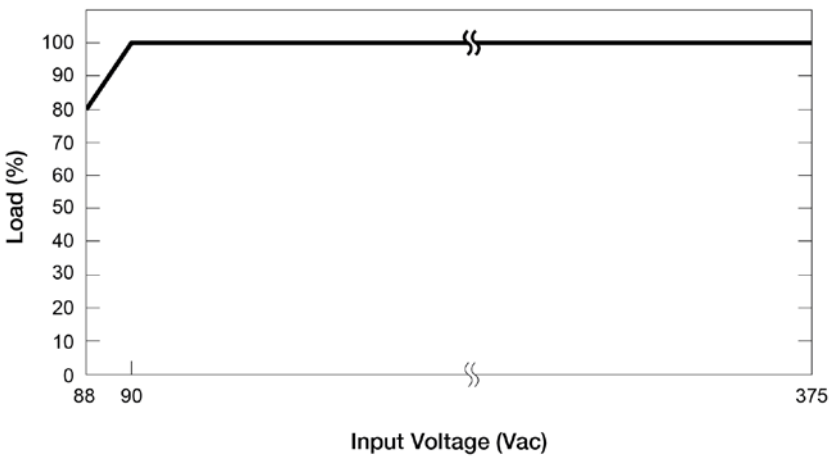

■ Output power de-rating for the DC input voltage range, refer to Fig. 7.

Fig. 7 De-rating for DC input voltage
 < 100Vdc de-rate power by 1.67% / V

CliQ III DIN Rail Power Supply

24V 120W 1 Phase / DRP-24V120W1C□N

Assembly & Installation

The power supply unit (PSU) can be mounted on 35mm DIN rails in accordance with EN 60715. For Vertical Mounting, the device should be installed with input terminal block at the bottom. For Horizontal Mounting, the device should be installed with input terminal block on the left side.

Each device is delivered ready to install.

1. Tilt the unit upwards and insert it onto the DIN rail. Snap on the DIN rail as shown in Fig. 8.1.
2. Push downwards until stopped.
3. Press against the bottom front side for locking.
4. Shake the unit slightly to ensure that it is secured.
5. To uninstall, pull or slide down the latch with screw driver as shown in Fig. 8.2. Then slide the power supply unit (PSU) in the opposite direction, release the latch and pull out the power supply unit (PSU) from the rail.

Mounting

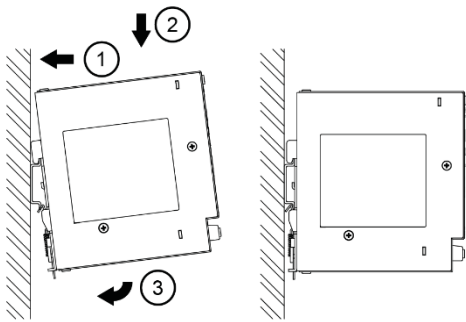

Fig. 8.1 Mounting

Dismounting

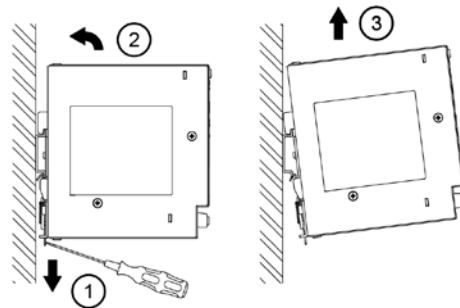

Fig. 8.2 Dismounting

In accordance to EN 60950 / UL 60950, flexible cables require ferrules.

Use appropriate copper cables designed to sustain operating temperature of:

1. 60°C, 60°C / 75°C for USA
2. At least 90°C for Canada

CliQ III DIN Rail Power Supply

24V 120W 1 Phase / DRP-24V120W1C□N

Safety Instructions

■ Vertical Mounting

■ Horizontal Mounting

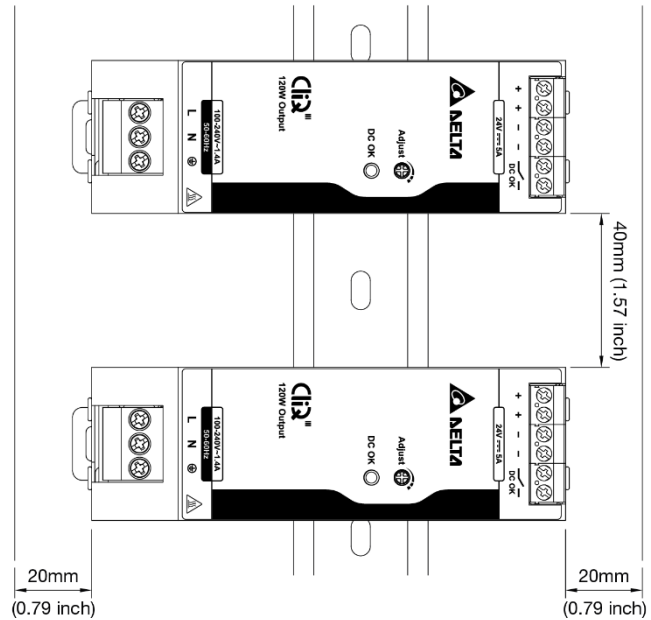
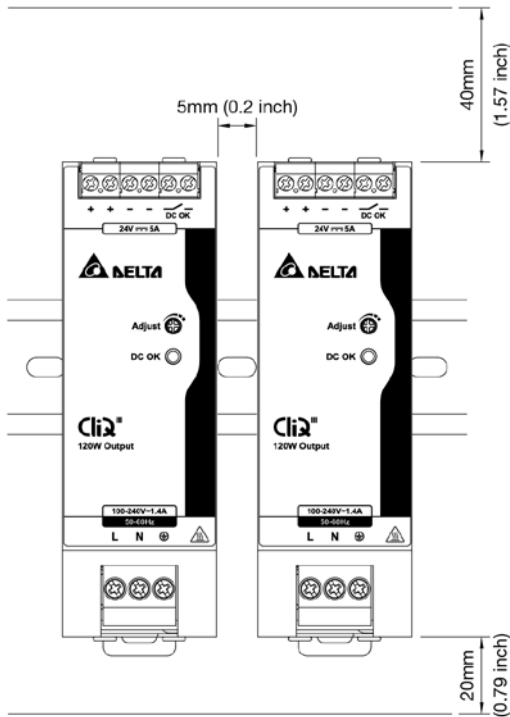

- ALWAYS switch mains of input power OFF before connecting and disconnecting the input voltage to the device. If mains are not turned OFF, there is risk of explosion / severe damage.
- If the unit is used in a manner not specified by the manufacturer, the protection provided by the equipment may be impaired.
- **To guarantee sufficient convection cooling, please refer to the following instructions to ensure sufficient clearance around the device.**

Vertical Mounting: 40mm (1.57 inch) above and 20mm (0.79 inch) below the device as well as a lateral distance of 5mm (0.2 inch) to other units. In case the adjacent device is a heat source, the lateral distance will be 15mm (0.6 inch).

Horizontal Mounting: 40mm (1.57 inch) above and below the device as well as a lateral distance of 20mm (0.79 inch) to other units.

- The external enclosure where the unit will be installed shall meet the requirements for mechanical, electrical and fire enclosure.
- Note that the enclosure of the device can become very hot depending on the surrounding air temperature and output load connected to the device. Risk of burns!
- The main power must be turned off before connecting or disconnecting wires to the terminals.
- DO NOT insert any objects into the unit.
- Dangerous voltages present for at least 5 minutes after disconnected all sources of power.
- The power supplies are built in units and must be installed in a cabinet or room (condensation free environment and indoor location) that is relatively free of conductive contaminants.

CliQ III DIN Rail Power Supply

24V 120W 1 Phase / DRP-24V120W1C□N

Functions

DC OK Relay Contacts and LED Indicator Characteristics

DC OK Relay Contacts Status	Characteristics
Contact closes	The output voltage reaches 90% of its steady state set value.
Contact opens	The output voltage dip lower than 90% of its steady state set value.

Operating Status	DC OK (Green LED)	DC OK Relay Contact
Normal Operation	ON	Closed
During Power Boost	ON	Closed
Overload ($V_{out} \leq 90\%$ of adjusted voltage)	OFF	Open
Output Short Circuit	OFF	Open
Over Temperature	OFF	Open
No Input Power	OFF	Open

CliQ III DIN Rail Power Supply

24V 120W 1 Phase / DRP-24V120W1C□N

■ Graph illustrating the Start-up Time, Rise Time, and Hold-up Time

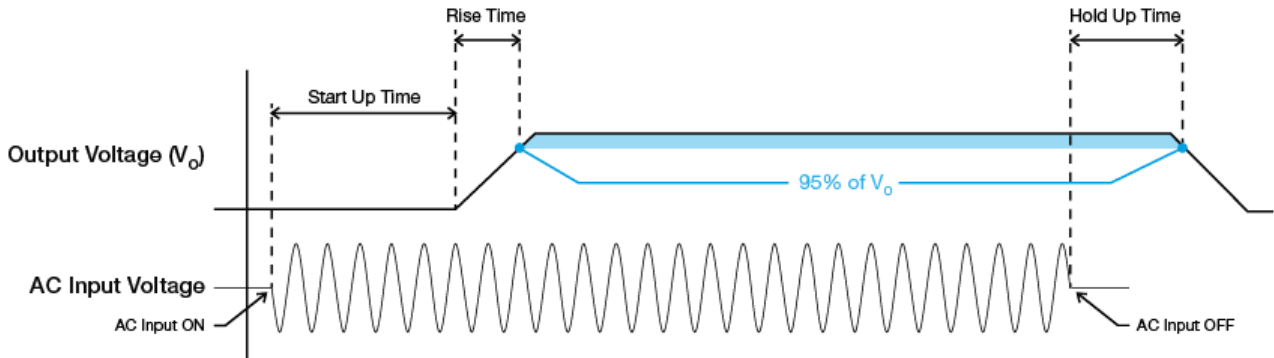

Start-up Time

The time required for the output voltage before output voltage rise up, after the input voltage is applied.

Rise Time

The time required for the output voltage to change from 0% to 95% of its final steady state set value.

Hold-up Time

Time between the collapse of the AC input voltage, and the output falling to 95% of its steady state set value.

Inrush Current

Inrush current is the peak, instantaneous, input current measured and, occurs when the input voltage is first applied. For AC input voltages, the maximum peak value of inrush current will occur during the first half cycle of the applied AC voltage. This peak value decreases exponentially during subsequent cycles of AC voltage.

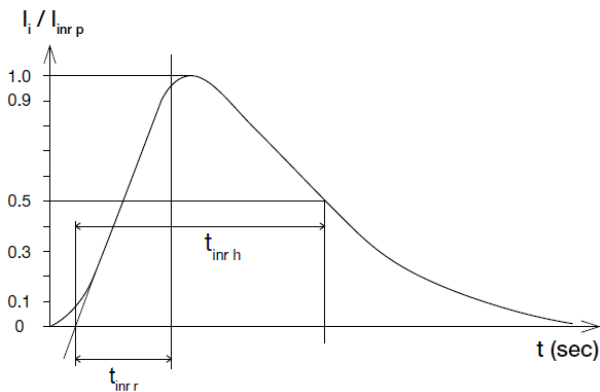

Dynamic Response

The power supply output voltage will remain within $\pm 5\%$ of its steady state value, when subjected to a dynamic load from 0A to 5A.

■ 50% duty cycle / 5Hz to 1KHz

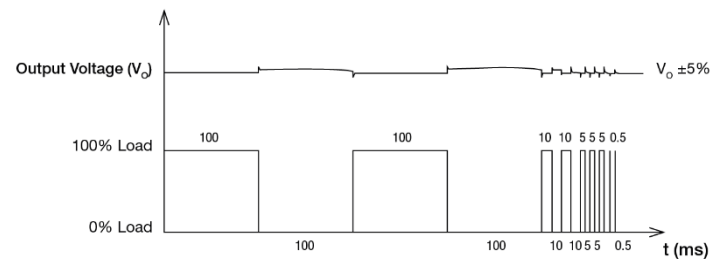

CliQ III DIN Rail Power Supply

24V 120W 1 Phase / DRP-24V120W1C□N

Overvoltage Protection (Auto-Recovery)

The power supply's overvoltage circuit will be activated when its internal feedback circuit fails. The output voltage shall not exceed its specifications defined on Page 6 under "Protections".

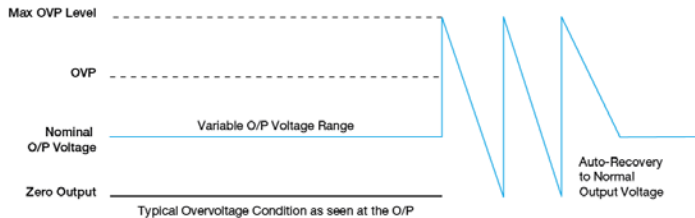

Overload & Overcurrent Protections (Auto-Recovery)

The power supply's Overload (OLP) and Overcurrent (OCP) Protections will be activated when output current is about 125 – 170% of output current (refer to ①) after 5sec typ. In such occurrence, the output current will limit to 8A typ. (at output voltage set value 24V) & 6.5A typ. (at output voltage set value 28V) and V_o (output voltage) will start to droop (refer to ②). Once V_o is below approximately 18Vdc typ., the power supply will start to operate in "Hiccup mode" (refer to ③). The power supply will recover once the fault condition due to OLP or OCP is removed, then I_o is back within its specified limits.

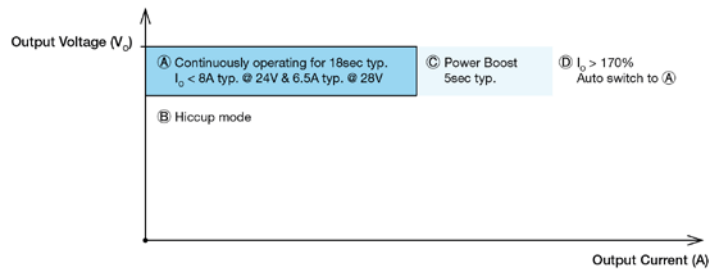

It is not recommended to prolong the duration of output current when it is <125% but >100%, since it may cause damage to the PSU.

Short Circuit Protection (Auto-Recovery)

The power supply's output Short Circuit Protection function also provides protection against short circuits. When a short circuit is applied, the output current will start to operate in "Hiccup mode". The power supply will return to normal operation after the short circuit is removed.

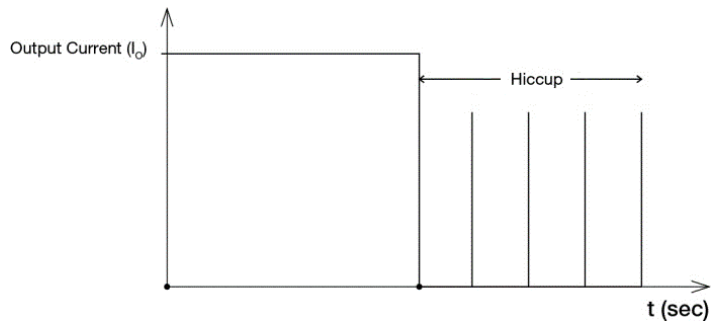

Over Temperature Protection (Auto-Recovery)

As described in load de-rating section, the power supply also has Over Temperature Protection (OTP). In the event of a higher operating temperature at 100% load, the power supply will run into OTP when the operating temperature is beyond what is recommended in the de-rating graph. When activated, the output voltage will go into bouncing mode until the temperature drops to its normal operating temperature as recommended in the de-rating graph.

CliQ III DIN Rail Power Supply

24V 120W 1 Phase / DRP-24V120W1C□N

Power Boost

Power Boost is the reserve power available constantly that allows reliable startup to support sudden and short spike of loads with high inrush current typically during turn on to remove the need of more expensive higher rated power supply unit. After the output has reached its steady state set value, the power supply can support surge loads with a higher short-term power demand up to 150% of maximum rated load (I_o Max), for a typical duration of 5 seconds. If the power boost lasts longer than typical duration, the output current will limit to 8A typ. (at output voltage set value 24V) & 6.5A typ. (at output voltage set value 28V) and V_o (output voltage) will start to droop, refer to the details in overload & overcurrent protections and the next Power Boost will be available after power boost recovery time defined on Page 4. In order to avoid this, need to maintain the duty cycle & recovery time to ensure that average (R.M.S) output power shall not exceed the continuous maximum, see duty cycle calculation below.

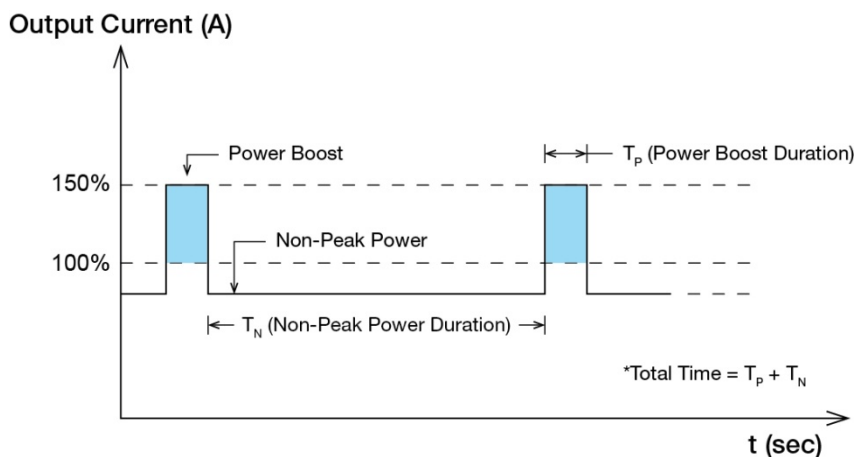

$$Duty\ cycle\ (\%) = \frac{T_p}{Total\ Time}$$

$$Average\ Output\ Power\ (P_{Avg}) = \frac{(Power\ Boost \times T_p) + (Non-Peak\ Power \times T_n)}{Total\ Time}$$

OR

$$Non-Peak\ Power = \frac{(P_{Avg} \times Total\ Time) - (Power\ Boost \times T_p)}{T_n}$$

■ An example of Power Boost and Average Output Power

Power Boost	Peak Power (W _P)	Power Boost Duration (T _P)	Duty Cycle	Non-Peak Power (W _N)	Non-Peak Power Duration (T _N)	Total Time (T)
150%	180	1 sec	10%	113W	9 sec	10 sec
150%	180	5 sec	30%	94W	11.5 sec	16.5 sec
125%	150	1 sec	10%	117W	9 sec	10 sec
125%	150	5 sec	30%	107W	11.5 sec	16.5 sec

CliQ III DIN Rail Power Supply

24V 120W 1 Phase / DRP-24V120W1C□N

Advanced Power Boost (APB)

With multiple loads connected in a system and due to one of fault load a large inrush current is drawn (demanded), this will be detected by APB. This APB will trip the circuit breaker (circuit breaker with appropriate rating base on the system load) on the current path of faulty load due to high current. This thus prevents the system from shutting down while the other connected current paths continue to operate without interruption.

The following waveforms demonstrate the typical output voltage and output current when APB is activated.

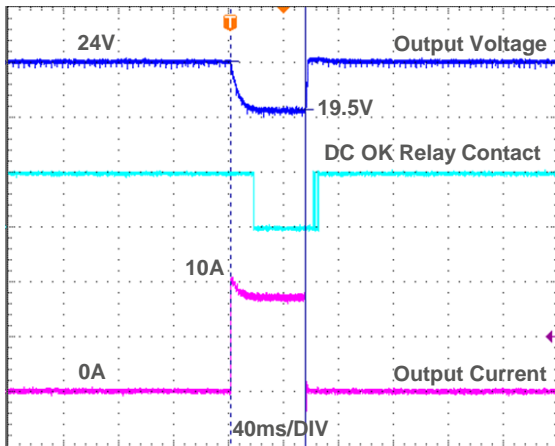

Fig. 9 APB 200% of nominal output current for 50ms

External Input Protection Device

The unit is protected at the L pin, with an internal fuse that cannot be replaced. The power supply has been tested and approved on 20A (UL) and 16A (IEC) branch circuits without additional protection device. An external protection device is only required if the supplying branch has an ampacity greater than above. Thus, if an external protective device is necessary, or, utilized, a minimum value of 8A C-characteristic breaker should be used.

CliQ III DIN Rail Power Supply

24V 120W 1 Phase / DRP-24V120W1C□N

Operating Mode

■ Redundant Operation

In order to ensure proper redundant operation for the power supply units (PSUs), the output voltage difference between the two units must be kept at 0.45~0.50V for these 24V supplies. Follow simple steps given below to set them up for the redundant operation:

Step 1.

Measure output voltage of PSU 1 and PSU 2. If PSU 1 is the master unit, then V_O of PSU 1 must be higher than PSU 2. In order to set the output voltage, individually connect each power supply to 50% of rated load at any line voltage from 88-264Vac, and set the PSU 1 and PSU 2 output voltage.

Step 2.

Connect the power supply units PSU 1 and PSU 2 to V_{in1} & V_{in2} , respectively, of the DRR-20N (or 20A) module shown on the right of above diagram.

Step 3.

Connect the system load to V_{out} . Please note that output voltage V_{out} from DRR module will be $= V_O$ (output voltage of power supply) $- V_{drop}^*$ (in DRR module).

* V_{drop} will vary from 0.60V to 0.90V (Typical 0.65V) depending on the load current and surrounding air temperature.

■ Parallel Operation

The power supply units (PSUs) can also be used for parallel operation in order to increase the output power. The difference in output voltage between the two units must be kept to within 25mV of each other. This difference must be verified with the same output load connected independently to each unit.

Parameters such as EMI, inrush current, leakage current, PARD, start up time will be different from those on the datasheet, when two units are connected in parallel. The user will need to verify that any differences will still allow the two power supplies connected in parallel will work properly in their product/application.

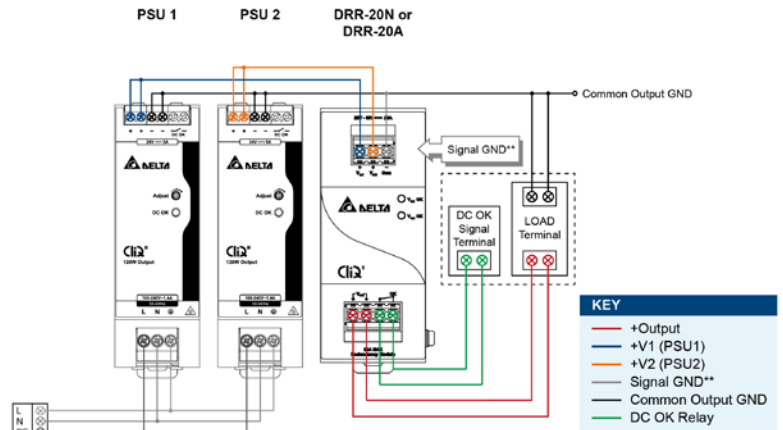

**The Signal GND in the DRR module is for the built-in LED and DC OK signals. The Output GND terminals from the two PSU's do not need to be connected to the Signal GND terminal.

Fig. 10 Redundant Operation Connection Diagram

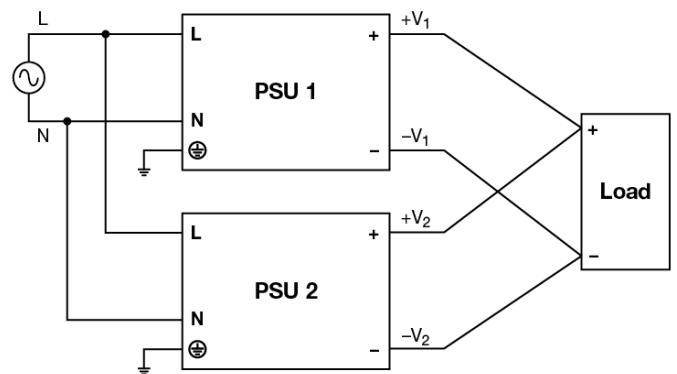

Fig. 11 Parallel Operation Connection Diagram

CliQ III DIN Rail Power Supply

24V 120W 1 Phase / DRP-24V120W1C□N

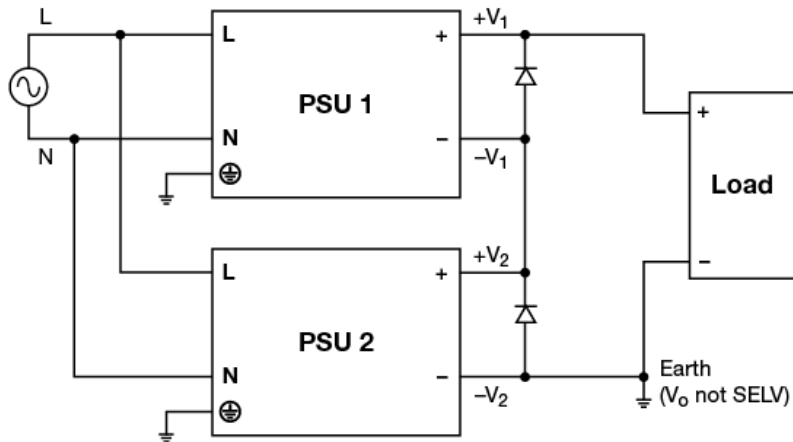
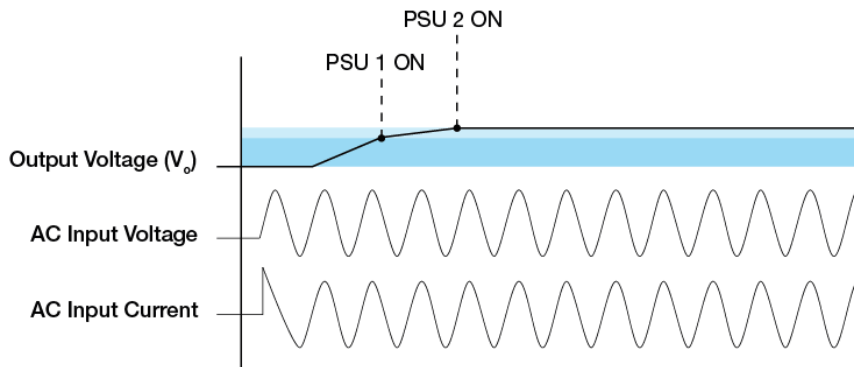

Fig. 12 Series Operation Connection Diagram

Series Operation

Delta's CliQ III can be connected in series to increase the output voltage as shown in figure above. Only power supply from the same product series, and with the same rated output current, can be used. The maximum load current should not exceed the smallest rated output current. Any number of power supplies can be connected in series. User must note that an output voltage > 60Vdc will not meet SELV requirements and could be dangerous to user, the total voltage shall not exceed 150Vdc. Installation a protection against the touching is a must and connect the output ground to earth when output voltage is not SELV. A diode in reverse bias must be added across output terminals of each power supply, this is to prevent -V voltage being applied to other power supply in fault conditions such as short circuit across load. During the short circuit -V₁ & +V₁ will come across +V₂ & -V₂ which means connecting 2 power supplies in opposite polarity and may cause damage to power supply. With reverse bias diodes in place the voltage across each power supply will be restricted to one diode drop – approximately 0.7V to 1.0V. It is recommended to provide sufficient voltage de-rating for diodes with 2 times the voltage rating of series output voltage. E.g. the two 24V power supplies are connected in series, the total voltage is 48 volts. Hence, recommended to use diodes with reverse voltage rating of 2x48=96 volts. Therefore, diodes with reverse voltage rating of 100 volts can be used.

During the short circuit condition, the current through diodes will be large, hence it is recommended that diodes to be least twice the current rating of the power supply.



The turn ON would be non-monotonic as the power supply with the fastest startup time and rise time will turn on first. As a result, the combined output voltage waveform of the 2 power supplies connected in series will include a step.

User must consider to verify parameters such as EMI, inrush current, leakage current, PARD, start up time would differ from datasheet numbers as multiple power supplies in series.

CliQ III DIN Rail Power Supply

24V 120W 1 Phase / DRP-24V120W1C□N

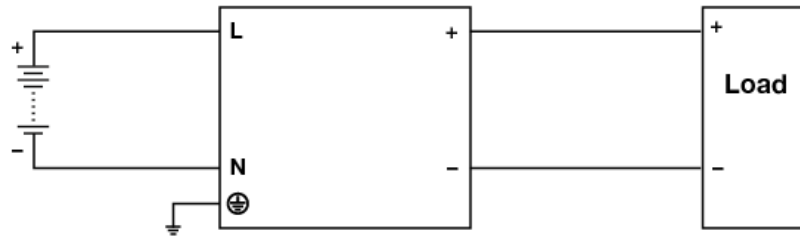

Fig. 13 DC Input Operation Connection Diagram

■ DC Input Operation

Step 1.
Use a battery or similar DC source.

Step 2.
Connect +pole to L and -pole to N.

Step 3.
Connect the PE terminal to an earth wire or to the machine ground.

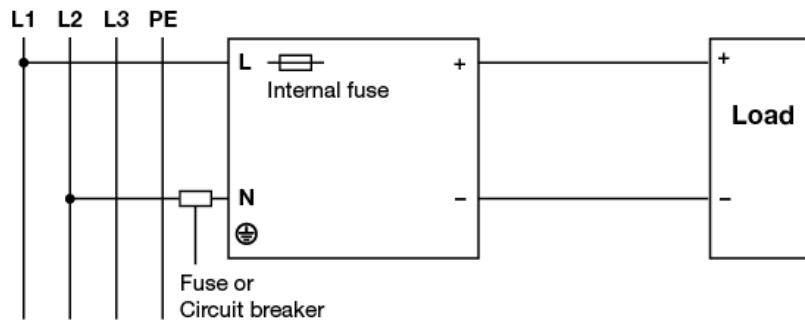

Fig. 14 2 of 3 Phase System Input Operation Connection Diagram

■ 2 of 3 Phase System Input Operation

Delta's CliQ III can use on 2 of 3 phase system. Please refer to the following step.

Step 1.
The input voltage applied from Line to Neutral is below the maximum rated input. The input voltage shall be below 240Vac +10%.

Step 2.
The external protector is needed on N (Neutral) input line to secure a safety. N line does not have internal fuse protection. An appropriate fuse or circuit breaker should be connected in series with N input line connection like the following.

CliQ III DIN Rail Power Supply

24V 120W 1 Phase / DRP-24V120W1C□N

Others

Delta RoHS Compliant



Restriction of the usage of hazardous substances

The European directive 2011/65/EU limits the maximum impurity level of homogeneous materials such as lead, mercury, cadmium, chrome, polybrominated flame retardants PBB and PBDE for the use in electrical and electronic equipment. RoHS is the abbreviation for "Restriction of the use of certain hazardous substances in electrical and electronic equipment".

This product conforms to this standard.

Conformal Coating

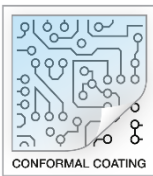

The Protective Coating Technology

Delta Electronics Group has designed the perfect dipping technique which penetrates everywhere including under device, and prevents leakage. The conformal coating dipping can be applied to PCBAs or circuit board. The coating preserves the performance of precision electronic primarily by preventing ionizable contaminants such as salt from reaching circuit nodes, where the material slumps around sharp edges. This can be a problem especially in highly conversing atmosphere.

PFC – Norm EN 61000-3-2

Line Current Harmonic content

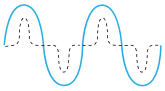

Typically, the input current waveform is not sinusoidal due to the periodic peak charging of the input capacitor. In industrial environments, compliance with EN 61000-3-2 is only necessary under special conditions. Complying to this standard can have some technical drawbacks, such as lower efficiency; and, can also result in higher product cost. Frequently, the user does not profit from compliance to this standard; therefore, it is important to know whether it is mandatory to meet this standard for a specific application.