

# The challenges and opportunities for powering electric vehicles



# Understanding charging technology for battery electric vehicles

Automotive design engineers find themselves at a very exciting confluence of technologies as we enter a new decade. Battery technology has reached a point where electrically-powered vehicles can be developed with meaningful amounts of energy stored to bring vehicle occupants from A to B, while offering both an exciting and familiar driving experience. In parallel, semiconductor technology provides ever increasing levels of measurement accuracy, incorporated in today's Battery Management

Systems (BMS), while next-generation switching technology is allowing us to attain the final few percentage points of efficiency improvement in power conversion systems as energy flows to the tires when driving, and battery when charging. This ensures that more energy than ever before is contributing usefully.

Despite the growth in battery capacity as battery electric vehicles (BEV) have matured, range anxiety still remains the biggest barrier to their adoption, according to UK fleet managers<sup>1</sup>. 80% state this as their primary concern, leading them to consider BEVs only for certain drivers within their fleets. Furthermore, 41% stated charging infrastructure as an issue for adoption, despite only 3% of charging taking place on the road (compared to 60% charging at work and 30% at home).

However, speaking to actual users reveals a different picture. Drivers describe undertaking long journeys in their BEVs between cities and not being any more concerned about reaching their destination than they would have been in an internal combustion engine (ICE) vehicle. Networks of high-speed charging stations ensure that a significant portion of the battery can be charged in a reasonable time, compatible with the refilling time at gas station using an ultra-fast DC charger<sup>2</sup>. And, of course, vehicle manufacturers integrate trip planners into their navigation systems that ensure the necessary time and location for charging is reflected in the route chosen and journey time.



## THE STATE OF BEV CHARGING

As already highlighted, many BEVs are charged while parked when their owners are either at home or at work. This ensures that charging can take place without any time pressure, meaning that the standard AC outlet can be used to charge the vehicle (Figure 1). Charging solutions of this type fall into Level 1 of the Society of Automotive Engineers' (SAE) classification of electric vehicle supply equipment (EVSE). The solution consists of an AC/DC converter integrated into the vehicle, ensuring that the correct DC voltage is generated for charging the battery, while also monitoring for faults to protect the vehicle. These are commonly known as on-board chargers (OBC). This assumes single-phase 120 V<sub>AC</sub> capable of delivering up to 16 A (<2 kW). Assuming a domestic outlet, this would mean a 35 kWh battery would require significantly more than half-a-day to fully charge from empty<sup>3</sup>.

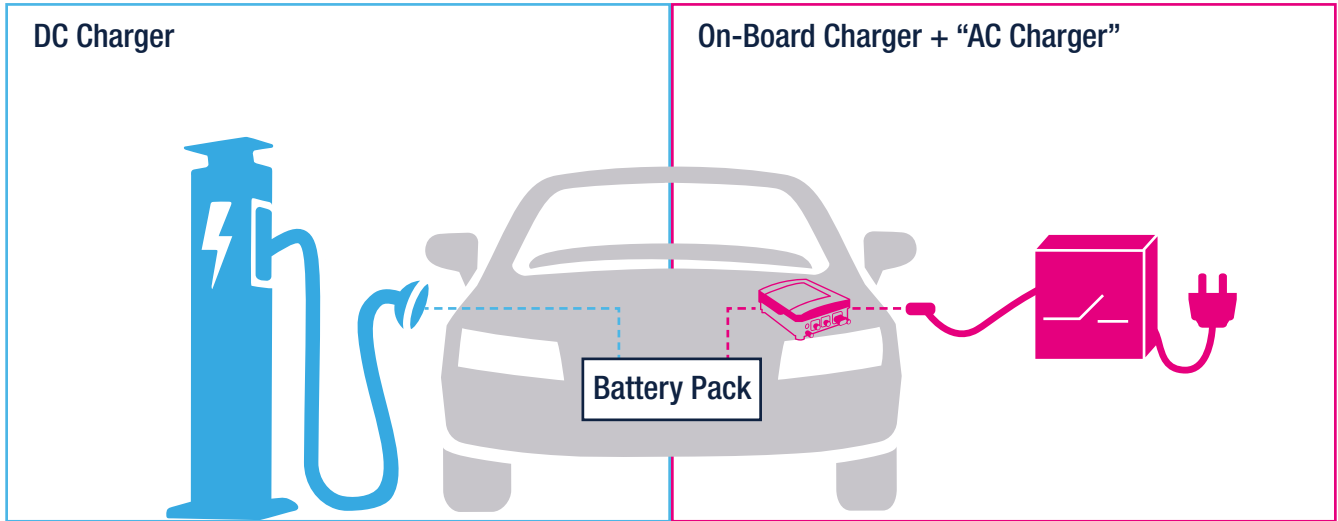

Figure 1: The Plug-In HEV and BEV charging options are split into AC On-Board Chargers and Off-Board DC Chargers

Level 2 solutions make use of two-phase 240 V<sub>AC</sub> supplies that can deliver up to 80 A (< 20 kW). This requires access to dedicated charging stations but brings charging times down to around six hours<sup>4</sup>.

Delivering power levels beyond this requires a move to DC charging. Here incoming AC is converted to DC in a standing solution, known as a charging pile and similar in design to a fuel pump, delivering up to 1000 V<sub>DC</sub> at 400 A (max. 400 kW). At these power levels, the ability of the battery system to accept the available charge becomes the limiting factor, so a mid-size family car could charge at 50 kW and gain 90 miles (144 km) per half hour<sup>5</sup>.

All of these standardized approaches are covered in both the SAE J1772 "SAE Electric Vehicle and Plug in Hybrid Electric Vehicle Conductive Charge Coupler" and SAE J3068 "Electric Vehicle Power Transfer System Using a Three-Phase Capable Coupler" standards that cover the North American market<sup>6 & 7</sup>. This also defines the 'J Plug', the electrical connector used in this market.

Of course, suppliers of charging solutions would prefer to have a single specification against which they can design, build and test BEV chargers. This should cover not only the voltages and powers supported, but also connectors and communication interfaces for detecting the vehicle's battery needs and to support billing.

To meet this need, both DC and AC charging approaches are encompassed in the CharIN e. V. group's Combined Charging System (CSS) specification, an open standard encouraging a worldwide universal charging system. This incorporates all existing standards, from those mentioned above as well as IEC 61851 and IEC 62196. This has also led to standardization of the connectors used. North America has coalesced around the Type 1 and Combo 1 system, while Europe has selected Type 2 and Combo 2, with the plug/socket providing AC only and AC/DC support respectively.

CSS is still being actively developed with the organization reaching out on topics such as wireless charging, high power charging for commercial vehicles (HPCCV) and automated connection devices (ACD) for underbody connection solutions.

Other regions and suppliers have undertaken different approaches. Japanese automotive suppliers have defined their CHAdeMO system, while GB/T is the system commonly in use in China. Some car makers have their own proprietary system.

## IMPLEMENTING FAST DC CHARGING

If charging our BEV is to be as smooth and simple as refueling our current vehicles, fast DC chargers need to provide significant quantities of power. In turn, this demands that they are also provided with suitable 3-phase power sources to be able to accomplish this. It is likely that this highest performance class of BEV charger will be located at highway service stations, providing the fast boost of charge needed along the route of longer journeys. The best performing BEVs on the market today are capable of attaining 80% of their charge using a 150 kW DC charger in just 33 minutes (max. 420 km range) and, with an upper limit of 350 kW for this charger type defined, there is still potential for even faster speeds<sup>8</sup>.

At these power levels, efficiency will be key, and the challenges are not to be underestimated. Losses will be significant not only in the electrical system but also in the cable between the charging pile and vehicle. This may even demand liquid cooling from charger to plug, something that will need to be considered in the overall design.

Fast DC chargers are typically implemented in one of two ways, both making use of an AC/DC stage followed by a DC/DC converter.

The first takes the incoming 3-phase AC and converts it into a fixed DC voltage, somewhere around 800 V, with the DC/DC converter stage setting the output to match the needs of the battery integrated into the vehicle. In the second approach, the AC/DC stage negotiates the required voltage required by the vehicle, generating a variable DC output that is used by the DC/DC converter (Figure 2). Neither approach is considered to provide any clear advantage over the other; instead it is more the implementation of each stage, specifically with a focus on highest efficiency, that is key. The complete charging unit will be made of several sub-units that, combined, deliver the target charging power. This eases construction, ensures that the charging pile continues to function if one sub-unit should fail, and makes repairs and upgrades simpler.

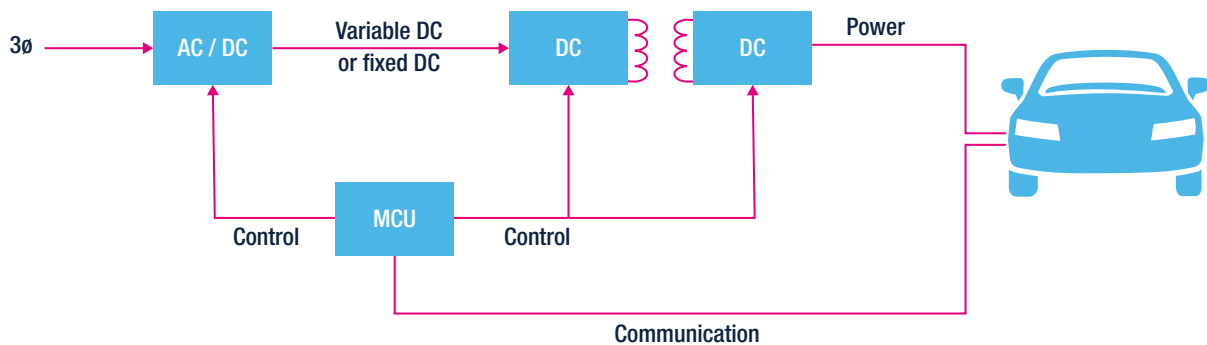

Figure 2: Architecture of a Fast DC Charger design, featuring a fixed- or variable-voltage DC link

A range of topologies offering superior efficiency can be considered for the AC/DC stage, but the Vienna rectifier for the rectification and power factor correction (PFC) is a strong contender. It can also generate a variable output voltage if required. The design is robust, even under fault conditions, capable of maintaining its output even with a loss of a phase. Should the switching control circuitry fail, there is also no risk of a short-circuit occurring. The three-level pulse-width modulated (PWM) design can be implemented with either two diodes in the incoming path (Type 1), or a single diode (Type 2).

The Type 1 approach only requires 650 V rated devices, leading to an overall lower cost for the switches selected but, due to the two diodes in the main current path, the maximum possible efficiency is impacted. In comparison, the Type 2 design can attain higher efficiencies with its single diode design, but this demands that 1200 V capable diodes are used (Figure 3). This can force the selection of silicon carbide (SiC) technology, something that will impact the overall cost.

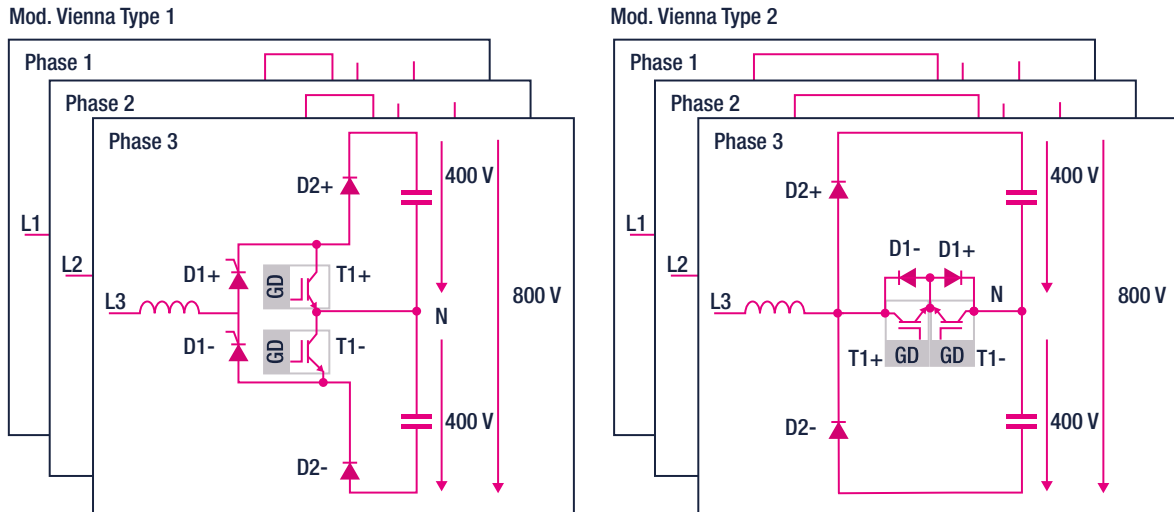
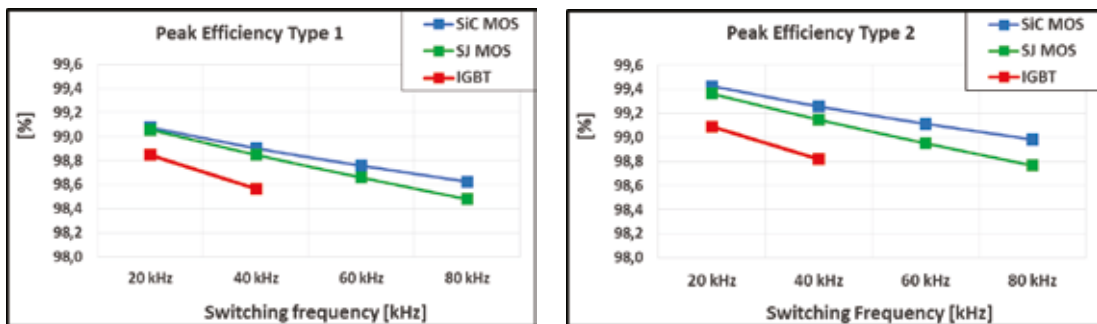

Figure 3: The Vienna rectifier is noted for its high efficiency and robustness as a PFC and AC rectifier

In the Type 2 design, a diode such as the STBR6012W is highly suitable. A silicon (Si) device, it supports a reverse repetitive voltage ( $V_{RRM}$ ) of 1200 V and an average forward current ( $I_{F(AV)}$ ) of 60 A. Provided in an ECOPACK™ package to meet environmental requirements, the DO-247 outline is easy to accommodate in both passively and actively cooled designs. The 1200 V STPSC40H12C SiC power Schottky diode could also be considered. Housed in a TO-247 LL package, it provides an  $I_{F(AV)}$  of 2 x 20 A. Thanks to SiC's stability over temperature, its switching characteristics remain remarkably consistent while the high forward surge capability is ideal during transient phases.

The switches can be implemented using the high-speed HB series of IGBT (STGW40H65DFB-4) that provide faster switching thanks to a Kelvin pin that separates power path and driving signal. Alternatively, 650 V M5 series power MOSFETs utilizing MDmesh™ technology could be used. This innovative vertical process lowers on-resistance, ideal for the high powers and target high efficiency demanded here. Finally, SiC 650 V power MOSFETs, such as the SCTW90N65G2V-4, with their 18mΩ  $R_{DS(on)}$  can comfortably handle 90 A of drain current at 100°C.

These options can deliver peak efficiencies of up to 99.4% at 20 kHz switching frequencies (simulated @ 125°C, semiconductor losses only), marginally beating the Type 1 Vienna approach thanks to the single diode in the main current path (Figure 4).



Simulated efficiency @  $T_j = 125^\circ\text{C}$ , considering only semiconductor losses.

Figure 4: Simulations show that SiC MOSFETs provide the highest efficiency in the Type 2 Vienna design.

Other approaches include the use of three single-phase PFC boosters, or a Totem Pole PFC design (Figure 5). The single-phase booster is elegant in its simplicity and is capable of attaining >98% efficiency at 1200 W for a 230 V<sub>AC</sub> input. The incoming AC is rectified using a rectifier (STBRxx12W) or thyristors (SCR), feeding a switch, inductor and diode. SiC MOSFETs and diodes provide the optimal combination, providing the necessary 1200 V operating voltage for the high DC link voltages involved. Control can be implemented using a continuous current mode PFC controller (STNRGPF01) or, if more intelligence is demanded, an STM32 microcontroller.

More demanding in the control side, the Totem Pole PFC requires a microcontroller, especially when implementing a MOSFET or SCR leg instead of just diodes. The MCU (STM32 or SPC58) can be coupled with an STGAP2S, a 4 A capable, rail-to-rail single gate driver with an 80 ns propagation delay, enabling high PWM control accuracy. It also provides a Miller clamp function to prevent gate spikes during fast commutations.

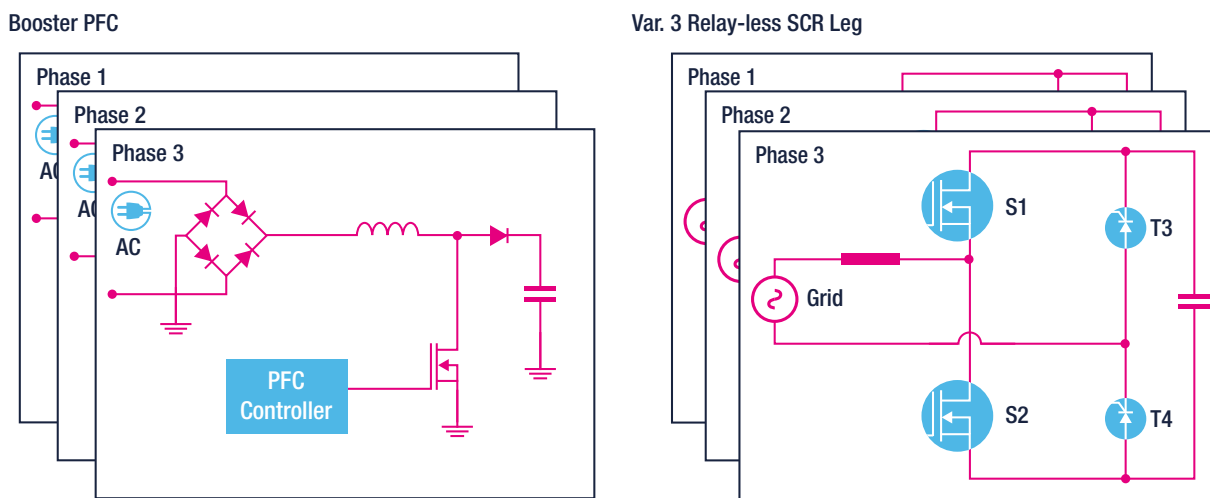

Figure 5: Alternative approaches for the AC/DC stage include Booster PFC (left) and variations on the Totem Pole PFC (right – relay-less SCR)

## THE DC/DC STAGE

The DC link voltage is passed to the DC/DC stage. One approach to this could be the use of a resonant LLC converter. The additional implementation of zero voltage switching (ZVS) contributes to their known superior efficiency and they offer high power density. This approach supports a variable DC link supply and integrates one of the primary side inductors into the transformer that also provides galvanic isolation. From here, typically battery voltages in the range of 200 V to 500 V can be attained.

Alternatively, a Dual Active Bridge (DAB) with bi-directional LLC could be considered. Increasingly Vehicle-to-Grid (V2G) or Vehicle-to-Building (V2B) is being touted as a way of utilizing the pending mass of BEV batteries to supplement the electric grid during times of peak usage or moments of power outage. This topology makes more sense in mid-power DC chargers that charge BEVs in car parks over the course of the day.

The previously mentioned MCU (STM32 or SPC58) and isolated driver devices are also well suited for system control and as switch driver. Thanks to their low  $R_{DS(on)}$ , SiC MOSFETs, 600 V or 1200 V depending on target output voltage, lend themselves to this DC/DC stage, being robust and suitable for compact designs. The resonant LLC can then make use of either 1200 V SiC diodes in a ZVS configuration, or soft ultrafast 600 V recovery diodes such as the STTH30RQ06 that provides high junction temperature capability and low reverse current and thermal resistance.

STMicroelectronics is developing a 7 kW charger evaluation board that can be stacked with two further boards of the same design to demonstrate a 21 kW DC charging solution (Figure 6). This particular design is based on an interleaved totem-pole PFC, using SiC MOSFETs, and an interleaved full-bridge LLC DC/DC converter, using 650 V super-junction silicon MOSFETs (Figure 7). With on-board charging one of the target applications, the board utilizes an automotive-qualified SPC58 N Line performance microcontroller. As well as being designed to fulfil ASIL-D safety level, making it ideal for BEV applications, it supports a broad range of automotive networking interfaces. The on-board Hardware Security Module (HSM) could also be used to provide protection and security for Over-the-Air updates (OTA) or even the billing system for charging piles.



Figure 6: The 7kW On-Board Charger module demonstrates the capability of SiC and silicon MOSFET, driver, thyristor, and SPC58 microcontroller technologies

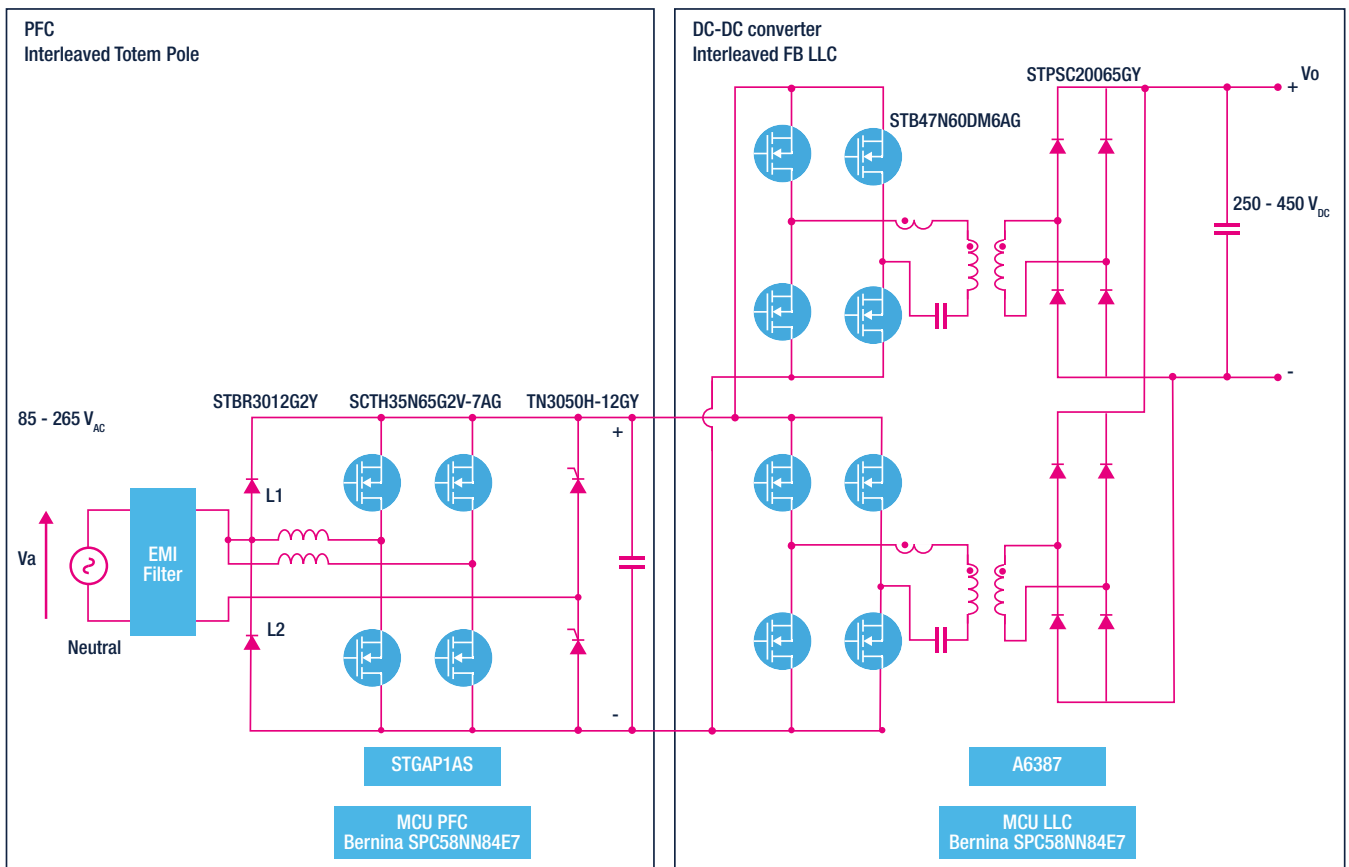

Figure 7: Schematic of the 7kW On-Board Charger design, including PFC and Interleaved FB LLC. [taken from OBC.pptx]

BEVs are coming of age, but there is still some pushback from consumers due to the perceived lack of charging infrastructure and charging times. Organizations such as CharIN are bringing relevant industry experts together to ensure that standards are defined, and that as many countries as possible sign up to them. This helps to ensure market size for BEV charging solutions are large enough to attain economies of scale. Simultaneously, advancements in MOSFET design, along with the introduction of SiC for both switches and diodes, is allowing design engineers to design and implement the fast DC charging solutions the automotive industry needs, while also ensuring highest possible levels of efficiency that fulfil challenging specifications. Partners such as STMicroelectronics provide not only the necessary state-of-the-art electronic components but, through their evaluation boards, much needed know-how and technical insight into this exciting automotive technology.

1. <https://www.fleetnews.co.uk/fleet-management/case-studies/industry-profiles/kia-motors-uk>
2. <https://thedriven.io/2019/11/24/the-death-of-range-anxiety-in-electric-vehicles/>
3. <https://www.drivingelectric.com/volkswagen/golf/e-golf/241/volkswagen-e-golf-range-battery-charging>
4. <https://www.plugincars.com/volkswagen-electric-e-golf-blue-e-motion>
5. [https://en.wikipedia.org/wiki/SAE\\_J1772](https://en.wikipedia.org/wiki/SAE_J1772)
6. [https://saemobilus.sae.org/content/J1772\\_201710/](https://saemobilus.sae.org/content/J1772_201710/)
7. [https://www.sae.org/standards/content/J3068\\_201804/](https://www.sae.org/standards/content/J3068_201804/)
8. [https://www.mobilityhouse.com/de\\_de/ratgeber/ladezeitenuebersicht-fuer-elektroautos](https://www.mobilityhouse.com/de_de/ratgeber/ladezeitenuebersicht-fuer-elektroautos)

For more information on ST products and solutions, visit [www.st.com](http://www.st.com)

© STMicroelectronics - May 2020 - Printed in United Kingdom - All rights reserved  
The STMicroelectronics corporate logo is a registered trademark of the STMicroelectronics group of companies  
All other names are the property of their respective owners



life.augmented