

1200 V, 20 mΩ SiC MOSFET

TM3B0020120A

Datasheet

Coherent Silicon Carbide power MOSFET offers improved efficiency, higher switching frequency and industry-leading 200 °C rating

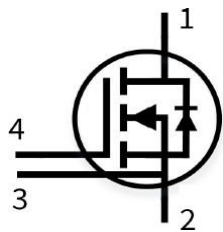
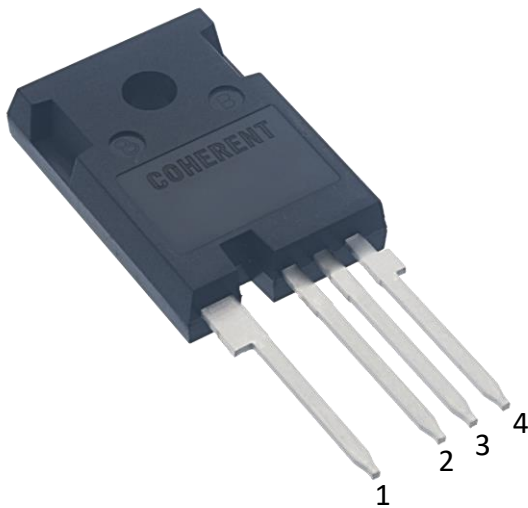

- 1 – Drain
- 2 – Source
- 3 – Kelvin sense contact
- 4 – Gate



- $V_{DSS} = 1200 \text{ V}$
- $R_{DS(ON)} = 20 \text{ m}\Omega$
- $T_{J,max} = 200 \text{ }^\circ\text{C}$

KEY FEATURES

- High voltage and low $R_{DS(ON)}$ up to 200 °C
- Fast switching enabled by ultra-low gate resistance
- Very low, temperature invariant switching losses
- Avalanche ruggedness superior to silicon
- Fast body diode for synchronous rectification
- RoHS compliant
- REACH compliant
- Pb-Free

KEY BENEFITS

- Higher system efficiency, performance and reliability
- Suitable for higher temperature and harsher environment
- Reduces cooling requirements, overall system cost and complexity
- Works in topologies with continuous hard commutation
- Increases power density
- Enables bidirectional topologies

MOSFET DC Characteristics @ $T_J = 25\text{ }^\circ\text{C}$ (unless otherwise specified)

Symbol	Parameter	Conditions	Min.	Typ.	Max.	Units
I_D	Continuous Drain Current	$V_{GS} = 20\text{ V}, T_C = 25\text{ }^\circ\text{C}, T_J = 200\text{ }^\circ\text{C}$	-	-	115	A
		$V_{GS} = 20\text{ V}, T_C = 100\text{ }^\circ\text{C}, T_J = 200\text{ }^\circ\text{C}$	-	-	87	
		$V_{GS} = 20\text{ V}, T_C = 125\text{ }^\circ\text{C}, T_J = 200\text{ }^\circ\text{C}$	-	-	75	
$I_{D,pulse}$	Pulsed Drain Current ¹⁾	$T_C = 25\text{ }^\circ\text{C}, T_J = 200\text{ }^\circ\text{C}$	-	-	173	A
I_D	Continuous Drain Current	$V_{GS} = 20\text{ V}, T_C = 25\text{ }^\circ\text{C}, T_J = 175\text{ }^\circ\text{C}$	-	-	109	A
		$V_{GS} = 20\text{ V}, T_C = 100\text{ }^\circ\text{C}, T_J = 175\text{ }^\circ\text{C}$	-	-	77	
		$V_{GS} = 20\text{ V}, T_C = 125\text{ }^\circ\text{C}, T_J = 175\text{ }^\circ\text{C}$	-	-	63	
P_{tot}	Power Dissipation	$T_C = 25\text{ }^\circ\text{C}$	-	-	660	W
$V_{(BR)DSS}$	Drain-Source Breakdown Voltage	$V_{GS} = 0\text{ V}, I_{DS} = 20\text{ }\mu\text{A}$	1200	-	-	V
I_{DSS}	Drain Leakage Current	$V_{DS} = 1200\text{ V}, V_{GS} = 0\text{ V}, T_J = 25\text{ }^\circ\text{C}$	-	-	20	μA
		$V_{DS} = 1200\text{ V}, V_{GS} = 0\text{ V}, T_J = 200\text{ }^\circ\text{C}$	-	-	200	
I_{GSS}	Gate-Source Leakage Current	$V_{GS} = -15/23\text{ V}$	-	-	100	nA
V_{GS}	Recommended Gate-Source Voltage		-	20	-	V
$V_{GS,max}$	Maximum Gate-Source Voltage	$V_{DS} = 0\text{ V}$	-	-	-15/23	V
V_{TH}	Gate-Source Threshold Voltage	$V_{GS} = V_{DS}, I_{DS} = 20\text{ mA}, J = 0.1\text{ A/cm}^2, T_J = 25\text{ }^\circ\text{C}$	2.0	2.8	3.8	V
		$V_{GS} = V_{DS}, I_{DS} = 20\text{ mA}, J = 0.1\text{ A/cm}^2, T_J = 175\text{ }^\circ\text{C}$	1.4	2.2	3.4	
$R_{DS(ON)}$	Drain-Source On-Resistance	$V_{GS} = 20\text{ V}, I_{DS} = 26\text{ A}, J = 133\text{ A/cm}^2, T_J = 25\text{ }^\circ\text{C}$	-	18.5	22.4	m Ω
		$V_{GS} = 20\text{ V}, I_{DS} = 75\text{ A}, J = 388\text{ A/cm}^2, T_J = 25\text{ }^\circ\text{C}$	-	19.7	24.3	
		$V_{GS} = 20\text{ V}, I_{DS} = 26\text{ A}, J = 133\text{ A/cm}^2, T_J = 200\text{ }^\circ\text{C}$	-	38.1	45.7	
		$V_{GS} = 20\text{ V}, I_{DS} = 51\text{ A}, J = 265\text{ A/cm}^2, T_J = 200\text{ }^\circ\text{C}$	-	39.3	47.7	
		$V_{GS} = 20\text{ V}, I_{DS} = 75\text{ A}, J = 388\text{ A/cm}^2, T_J = 200\text{ }^\circ\text{C}$	-	40.4	49.7	
g_{fs}	Forward Transconductance	$I_{DS} = 75\text{ A}, V_{DS} = 10\text{ V}$	-	30	-	S
$R_{GATE, ESR}$	Gate-Source Series Resistance	$V_{GS} = 0\text{ V}, \text{Drain Source Shorted}$	-	0.75	-	Ω
E_{AS}	Single Pulse Avalanche Energy	$I_D = 30\text{ A}, L = 8\text{ mH}$	-	3.6	-	J
R_{thJC}	Thermal Resistance, Junction-Case	Assumes TO247-4L Packaged Die	-	0.22	0.27	$^\circ\text{C/W}$
T_J, T_{stg}	Bare chip/Discrete Max Junction Operating and Storage Temperature		-55	-	200	$^\circ\text{C}$

MOSFET Dynamic Characteristics

Symbol	Parameter	Conditions	Min.	Typ.	Max.	Units
C_{ISS}	Input Capacitance	$V_{GS} = 0 \text{ V}, V_{DS} = 500 \text{ V}, f = 100 \text{ kHz}$	-	3982	-	pF
C_{OSS}	Output Capacitance		-	195	-	
C_{RSS}	Reverse Transfer Capacitance		-	14	-	
$t_{d(on)}$	Turn-on Delay Time	$V_{DS} = 600 \text{ V}, V_{GS} = -5/20 \text{ V}, I_D = 75 \text{ A}, R_{G(ext)} = 5.11 \Omega$	-	17	-	ns
t_r	Rise Time		-	39	-	
$t_{d(off)}$	Turn-off Delay Time		-	38	-	
t_f	Fall Time		-	12	-	
E_{ON}	Turn-on Energy	$V_{DS} = 600 \text{ V}, V_{GS} = -5/20 \text{ V}, I_D = 75 \text{ A}$ $R_{G(ext)} = 5.11 \Omega, L = 1.6 \text{ mH}$	-	0.91	-	mJ
E_{OFF}	Turn-off Energy		-	0.52	-	
E_{TOT}	Total Switching Energy		-	1.43	-	
Q_G	Total Gate Charge ²⁾	$V_{GS} = -5 \text{ to } 18 \text{ V}, I_{DS} = 60 \text{ A}, V_{DS} = 900 \text{ V}$	-	172	-	nC
Q_{GS}	Gate-Source Charge ²⁾		-	68	-	
Q_{GD}	Gate-Drain Charge ²⁾		-	48	-	

Diode Characteristics ³⁾

Symbol	Parameter	Conditions	Min.	Typ.	Max.	Units
I_{SD}	Pulsed Body Diode Current	$V_{GS} = 0 \text{ V}$	-	-	100	A
V_{SD}	Diode Forward Voltage	$V_{GS} = 0 \text{ V}, I_{SD} = 75 \text{ A}$	-	4.0	-	V
t_{rr}	Reverse Recovery Time	$I_F = 75 \text{ A}, V_R = 600 \text{ V}$	-	24	-	ns
Q_{rr}	Reverse Recovery Charge	@ $di/dt = 3239 \text{ A}/\mu\text{s}$	-	386	-	nC
I_{rrm}	Peak Reverse Current	$L_\sigma = 50 \text{ nH}, C_\sigma = 10 \text{ pF}$	-	32.0	-	A

¹⁾ Pulse width limited by $T_{J,max}$.

²⁾ Q_{GS} and Q_{GD} values were calculated using the two-curve extraction method shown in Fig. 12.

³⁾ We recommend the use of body diode in synchronous rectification mode with repetitive conduction during switch commutation dead-time $\leq 1\mu\text{s}$. Our long term (up to 13,000 hours) continuous switching test results show excellent reliability and forward voltage stability, indicating it is safe to use the body diode in this mode.

Figure 1. Output Characteristics

$$I_D = f(V_{DS}, V_{GS}); T_J = 25\text{ }^\circ\text{C}$$

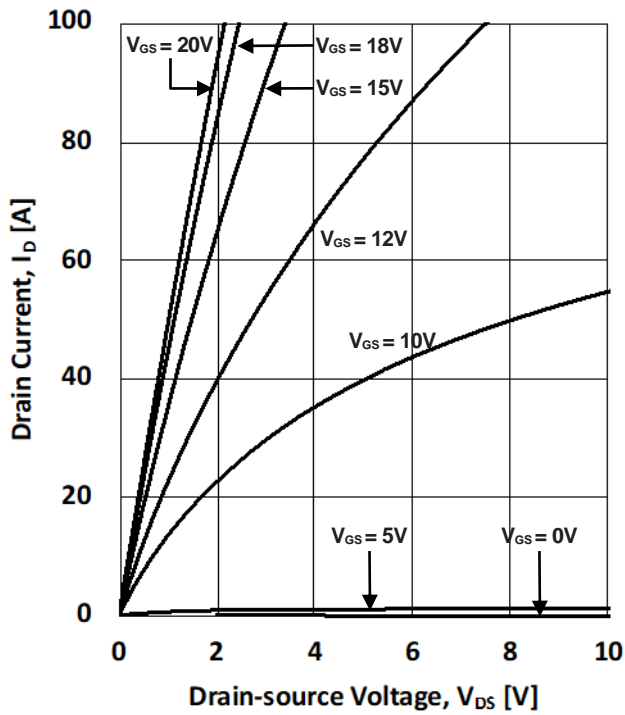

Figure 2. Output Characteristics

$$I_D = f(V_{DS}, V_{GS}); T_J = 200\text{ }^\circ\text{C}$$

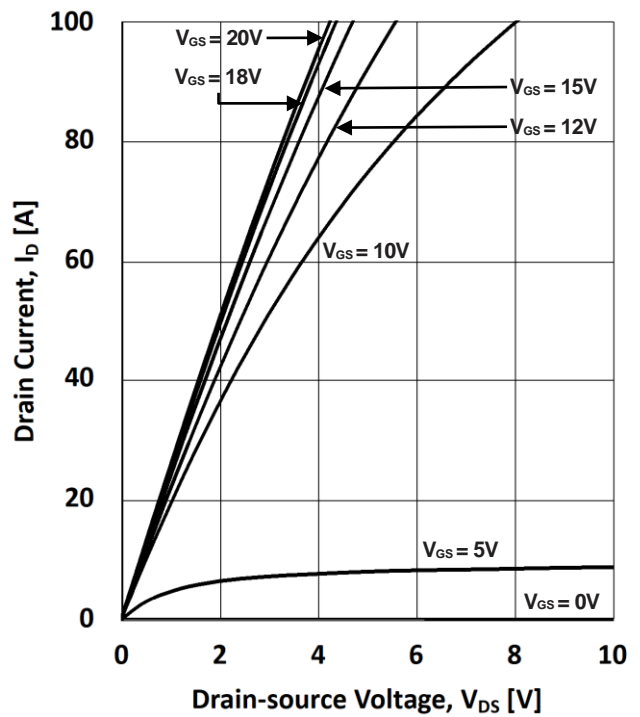

Figure 3. Threshold Voltage

$$V_t = f(T_J); V_{DS} = V_{GS}; I_D = 20\text{ mA}$$

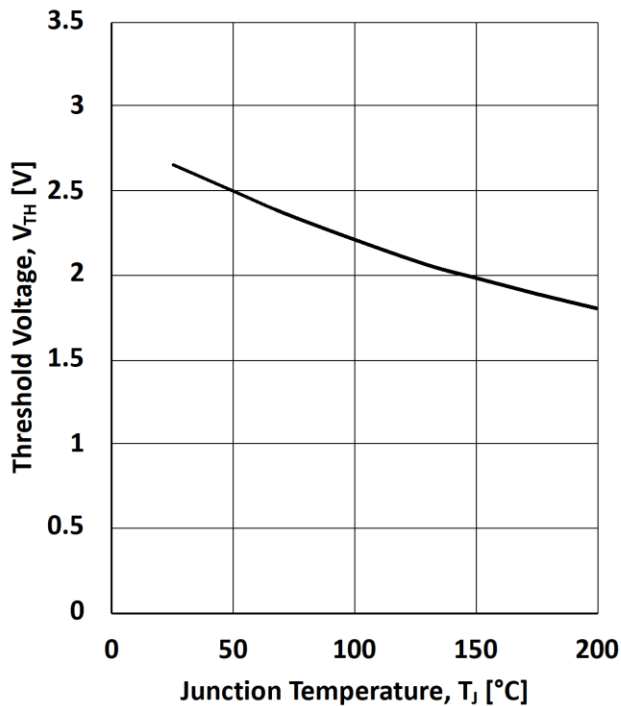

Figure 4. Drain-Source On-State Resistance

$$R_{DS(ON)} = f(T_J); I_D = 75\text{ A}$$

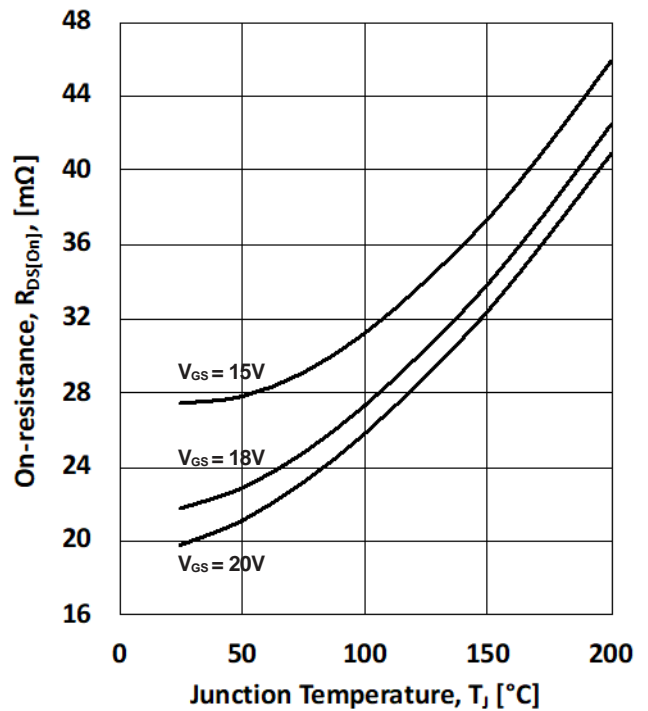

Figure 5. Drain-Source On-State Resistance

$$R_{DS(on)} = f(I_D); T_J = 25\text{ }^\circ\text{C}$$

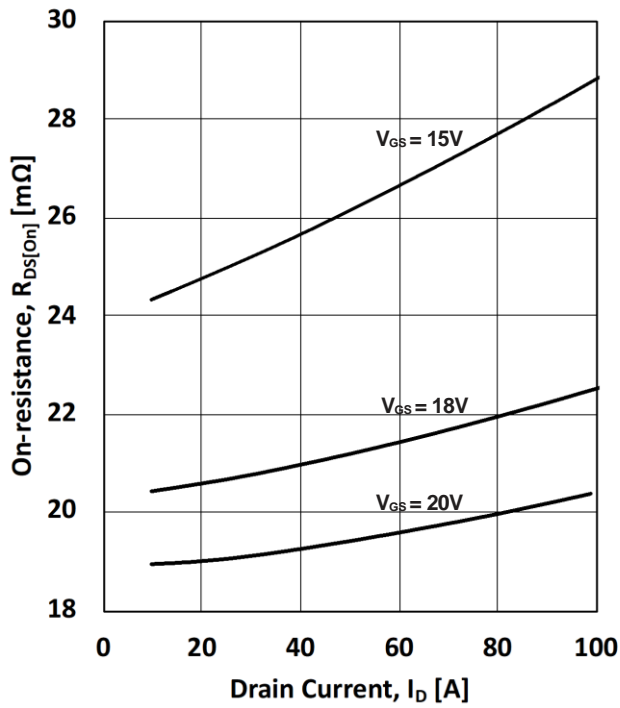

Figure 6. Drain-Source On-State Resistance

$$R_{DS(on)} = f(T_J); V_{GS} = 20\text{ V}$$

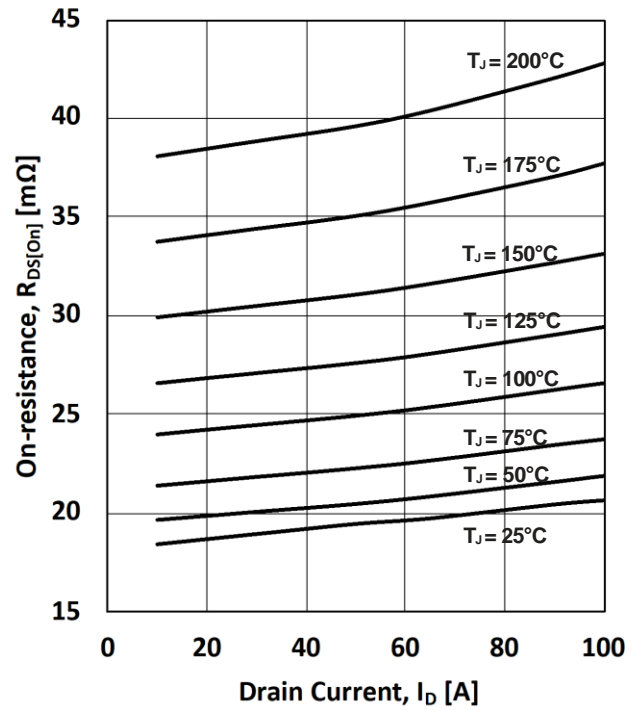

Figure 7. Third Quadrant Characteristics

$$I_D = f(V_{DS}, V_{GS}); T_J = 25\text{ }^\circ\text{C}$$

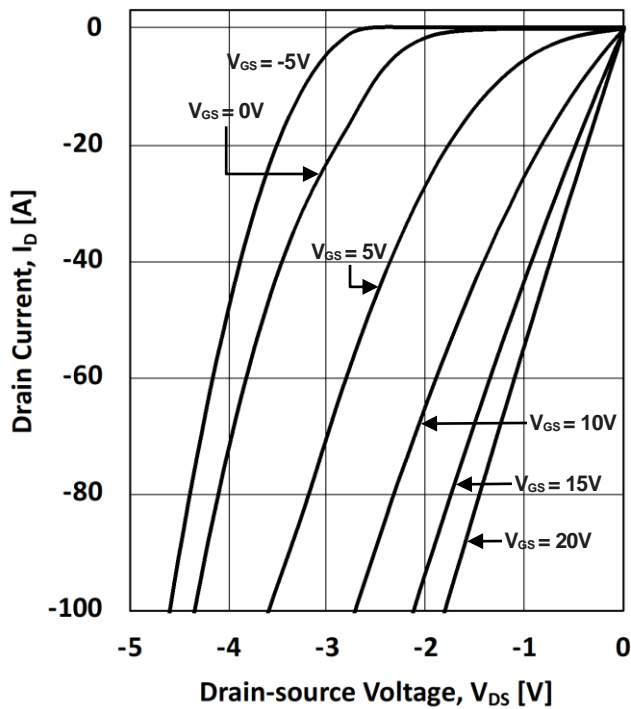

Figure 8. Third Quadrant Characteristics

$$I_D = f(V_{DS}, V_{GS}); T_J = 200\text{ }^\circ\text{C}$$

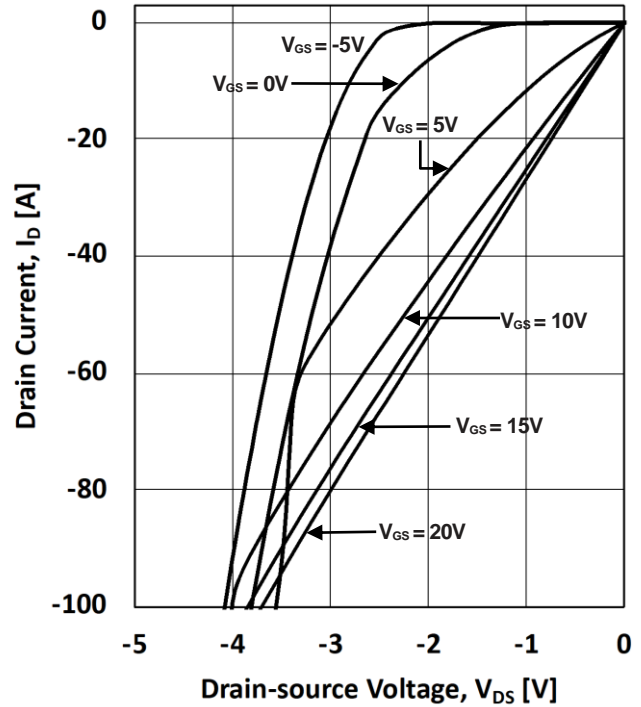

Figure 9. Capacitances
 $C = f(V_{DS}); f = 100 \text{ kHz}$

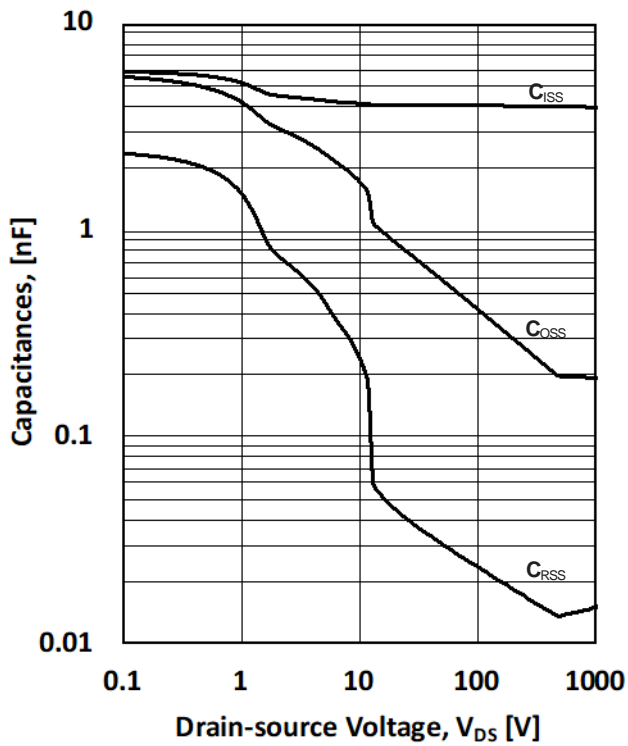

Figure 10. Inductive Switching Energies (See Fig. 17)
 $E_{ON} = f(I_D); E_{OFF} = f(I_D); E_{TOT_SW} = f(I_D)$

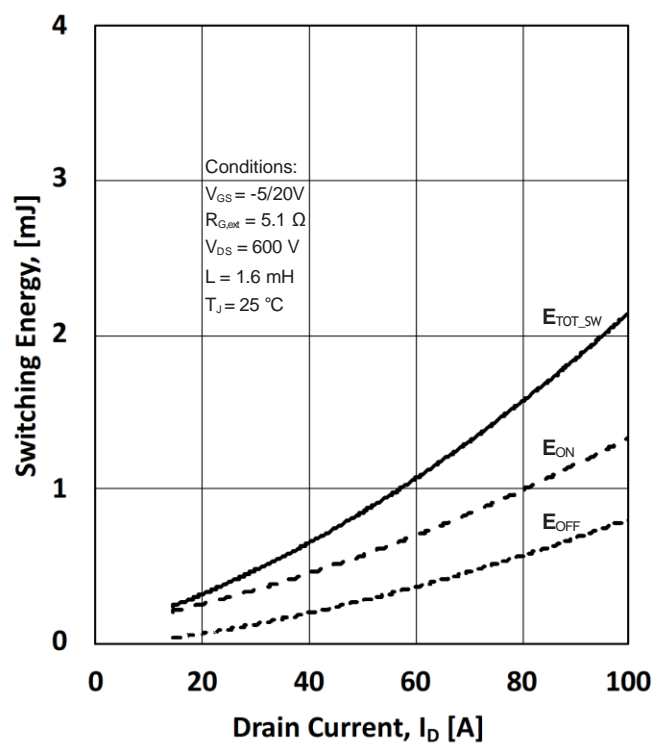

Figure 11. Typical Unclamped Inductive Switching Waveforms
 $I_D = f(t); V_{DS} = f(t)$

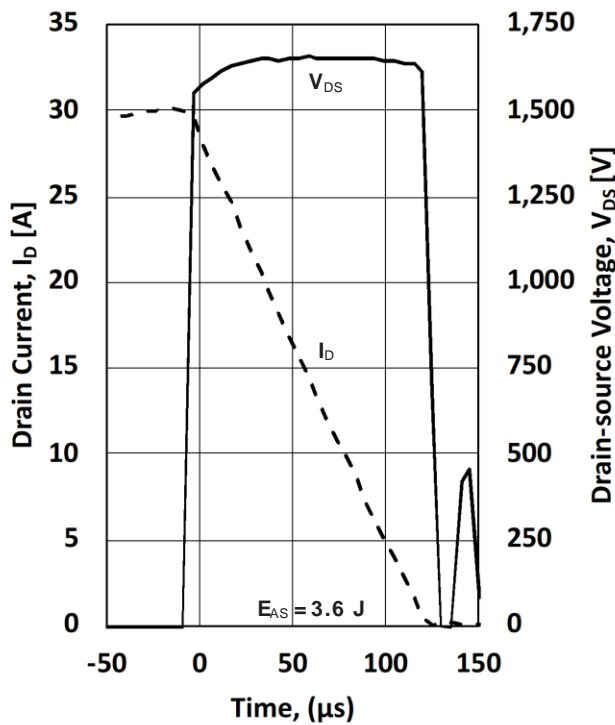

Figure 12. Gate Charge

$V_{GS} = (-5... +18\text{V}); V_{DS} = 900 \text{ V}; I_{DS} = 60 \text{ A}; T_J = 25 \text{ }^\circ\text{C}$

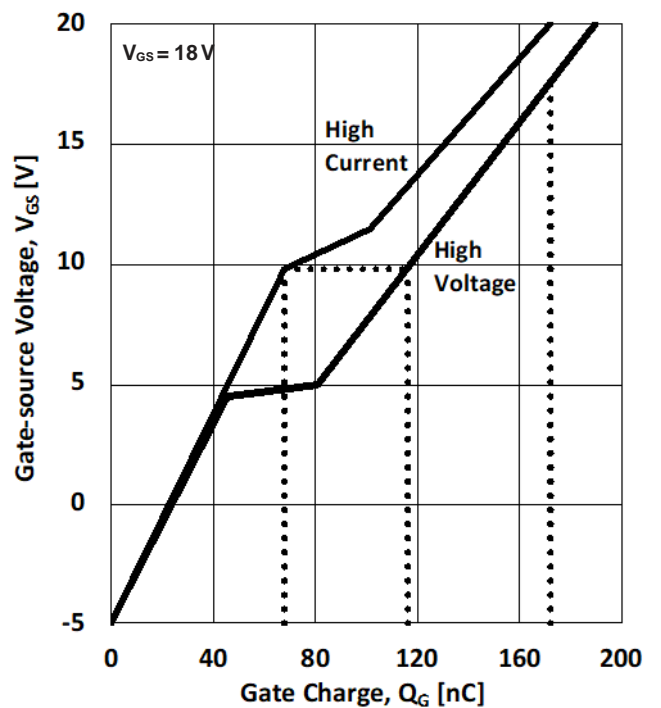

Figure 13. Transfer Characteristics

$$I_D = f(V_{GS}); V_{DS} = 10 \text{ V};$$

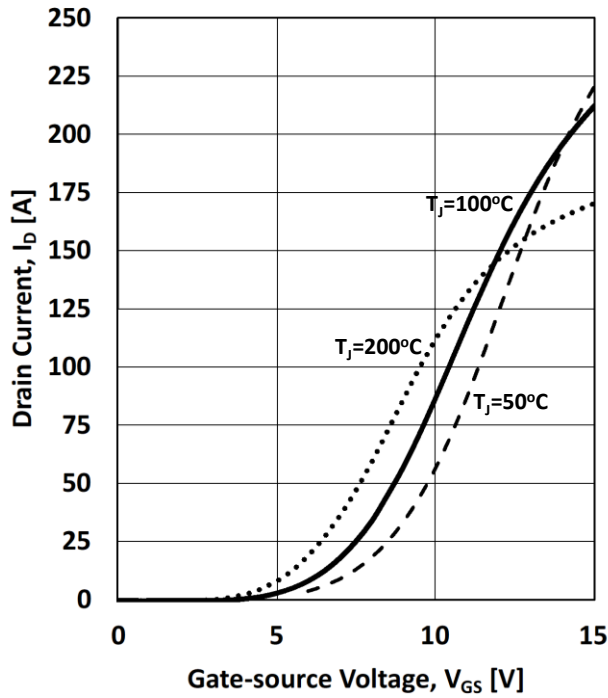

Figure 14. Power Dissipation

$$P_{tot} = f(T_C)$$

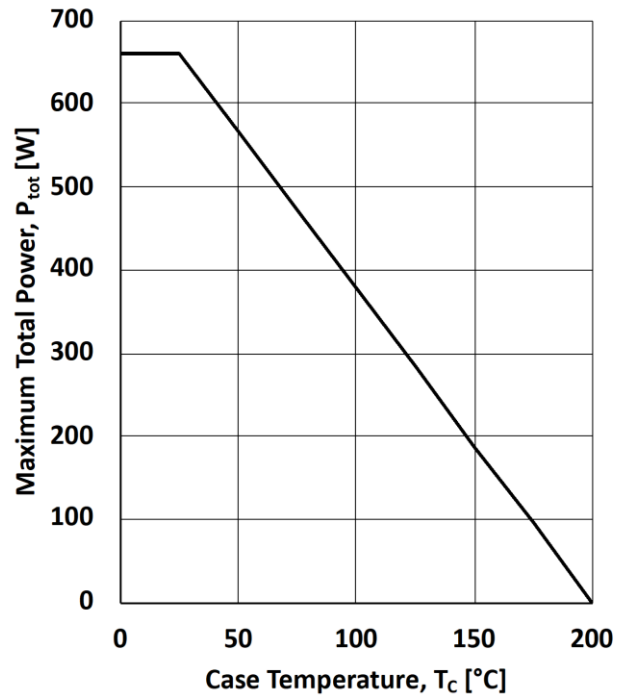

Figure 15. Transient Thermal Impedance

$$Z_{th,jc} = f(t_p, D); D = t_p / (\text{period})$$

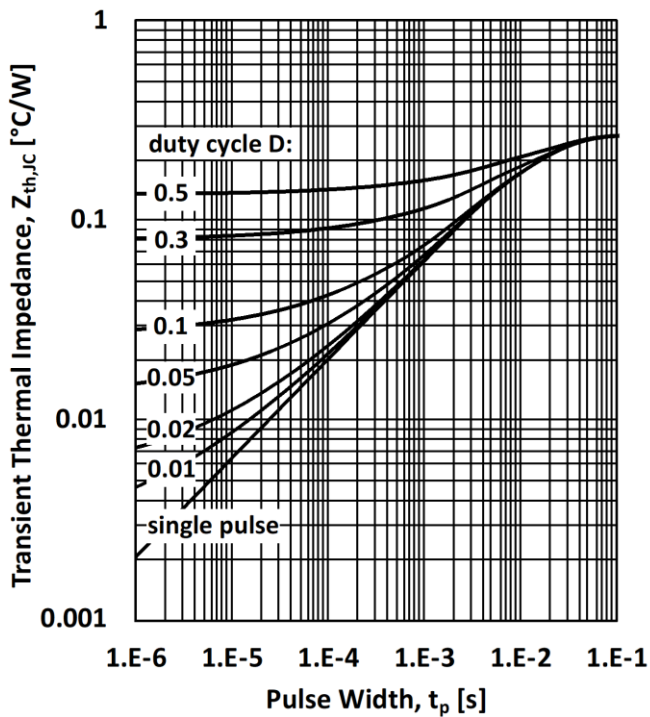

Figure 16. Safe Operating Area

$$I_D = f(V_{DS}, t_p); T_C = 25^\circ\text{C}; D = 0 \text{ (single pulse)}$$

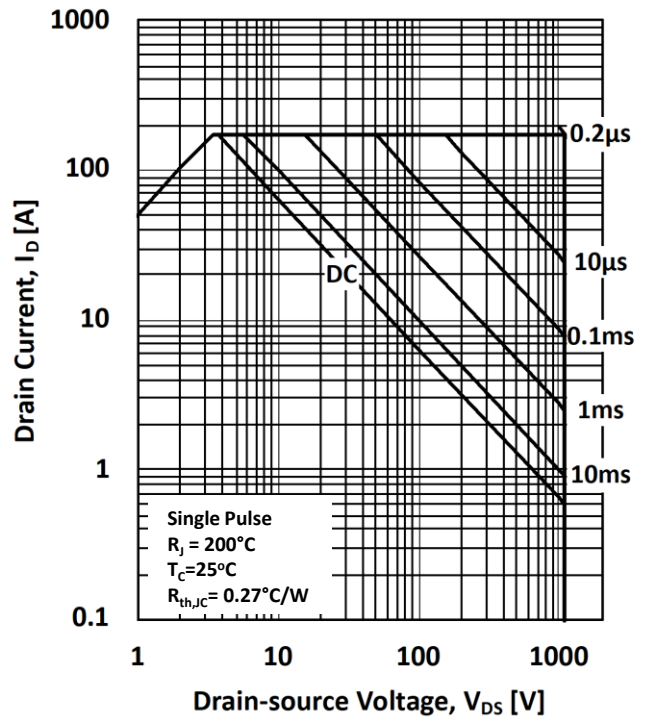

Figure 17. Clamped Inductive Switching Test Circuit

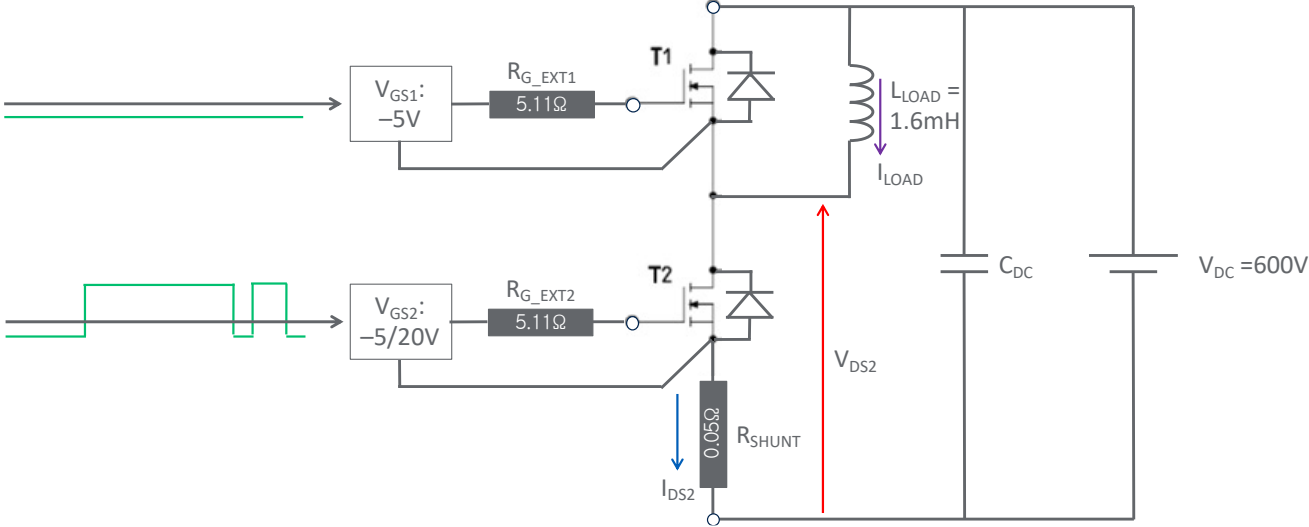

Figure 18. Switching Waveforms for Transition Times

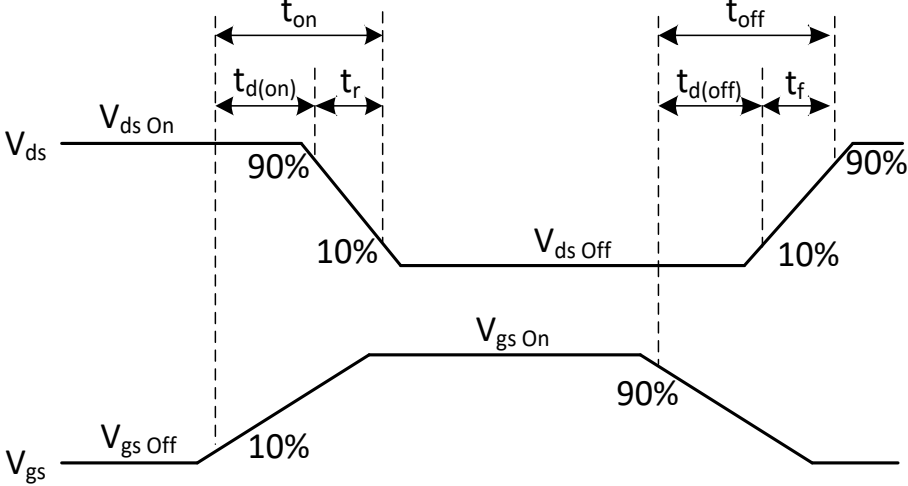
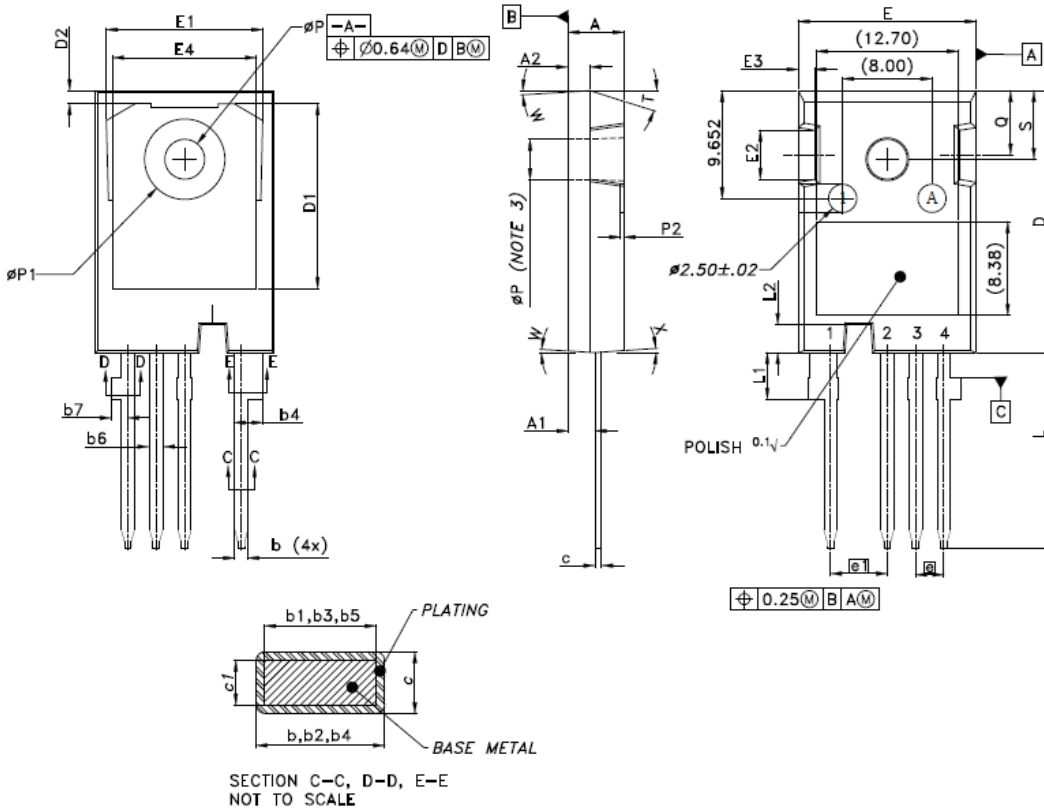

Figure 19. Part Dimensions (mm)



AREA	MIN	NOM	MAX
A	4.83	5.02	5.21
A1	2.29	2.415	2.54
A2	1.86	1.99	2.12
D	23.30	23.45	23.60
D1	15.85	16.55	17.25
D2	1.02	1.17	1.32
E	15.75	15.94	16.13
E1	13.89	14.02	14.15
E2	3.68	4.39	5.10
E3	1.00	1.45	1.90
E4	12.38	12.91	13.43
e	2.540 BSC		
e1	5.080 BSC		
L	17.31	17.57	17.82
L1	3.97	4.17	4.37
L2	2.35	2.50	2.65
b	1.07	-	1.33
b1	1.07	1.20	1.28
b2	2.39	-	2.64
b3	2.39	-	2.69
b4	2.39	-	2.94
b5	2.39	2.53	2.84
b6	1.07	-	1.60
b7	1.30	-	1.70
c	0.55	-	0.68
c1	0.55	0.60	0.65
ϕP	3.51	3.58	3.65
Q	5.49	5.75	6.00
S	6.04	6.15	6.30
$\phi P1$	7.18 REF		
T	17.5° REF		
W	3.5° REF		
X	4° REF		
P2	0.05	0.175	0.30

NOTES:

1. DIMENSIONS ARE IN MILLIMETERS
2. DIMENSION D & E DO NOT INCLUDE MOLD FLASH, MOLD FLASH SHALL NOT EXCEED 0.127 MM PER SIDE. THESE DIMENSIONS ARE MEASURED AT THE OUTERMOST EXTREME OF THE PLASTIC BODY.
3. ϕP TO HAVE A MAXIMUM DRAFT ANGLE OF 1.5° TO THE TOP OF THE PART WITH A MAXIMUM HOLE DIAMETER OF 3.65mm.
4. ADDED DIMENSION P2 TO SPECIFY EJECTION MARK DEPTH

Handling

These devices are sensitive to electrostatic discharge and proper handling procedures are recommended. Please refer to ESD standard.

Revision History

Reference	Date	Description
v1.0	Jan.05.2023	Preliminary Datasheet
v2.0	Feb.23.2024	Final Datasheet

Disclaimer

The data presented in this document are for informational purposes only and shall in no event be regarded as a guarantee of conditions or characteristics. Any warranty or license for this product shall be specified and governed by the terms of a separate purchase agreement. Coherent does not assume any liability arising out of the application or use of this product; neither does it convey any license under its patent rights, nor the rights of others.

Coherent reserves the right to make changes in specifications and features shown herein to improve reliability, function, or design, or discontinue this product, at any time without notice or obligation. Contact your Coherent representative for the most current information.

Warning

This product is not authorized for use (1) in life support systems or (2) for applications implanted into the human body, without the express written approval of Coherent.