

High-Throughput Ethernet Interface Solutions

High Performing, Power Efficient, Easy to Use





Maximum Reliable Bandwidth

Ethernet communication provides robust, reliable communication, offering real-time performance and Gigabit speeds ideal for a vast array of networking applications. Our comprehensive portfolio includes transceivers (PHYs), bridges, controllers and switches to accommodate large and small networks.

Ethernet Made Easy

- Tested to stringent IEEE® 802.3 standards at UNH-IOL
- Robust evaluation boards, application examples and notes
- Extensively tested, free drivers for MPLAB® Harmony, Windows®, macOS and Linux® operating systems
- Complimentary design review that leverages in-house Ethernet experts for your design (see below for details)

Our Ethernet Portfolio

Transceivers (PHYs)

- Speeds of up to 1 Gigabit for copper and 10 Gigabits for optical
- Commercial-, industrial- and automotive-grade
- Enhanced EMC robustness

Bridges

- Enable Ethernet with your processor's USB/PCIe® port

Controllers

- Add Ethernet with reduced microcontroller (MCU)/ MPU/SoC overhead via a variety of processor interfaces

Switches

- Up to 64 ports, up to 25 Gigabit speeds, advanced features and industrial and automotive temperatures

Applications

- Internet of Things (IoT)
- Point-of-sale machines
- Home/building/lighting automation
- Smart energy/smart grid
- Remote equipment monitoring
- Security and IP cameras
- Industrial sensors and controls
- Automotive/in-vehicle networking
- IP telephony
- Media players/set-top boxes
- Digital televisions
- Wireless 4G/LTE modems
- Broadband modems and routers
- Network infrastructure (routers, switches, access points and bridges)
- Wireless 5G small cell



Our Ethernet Products

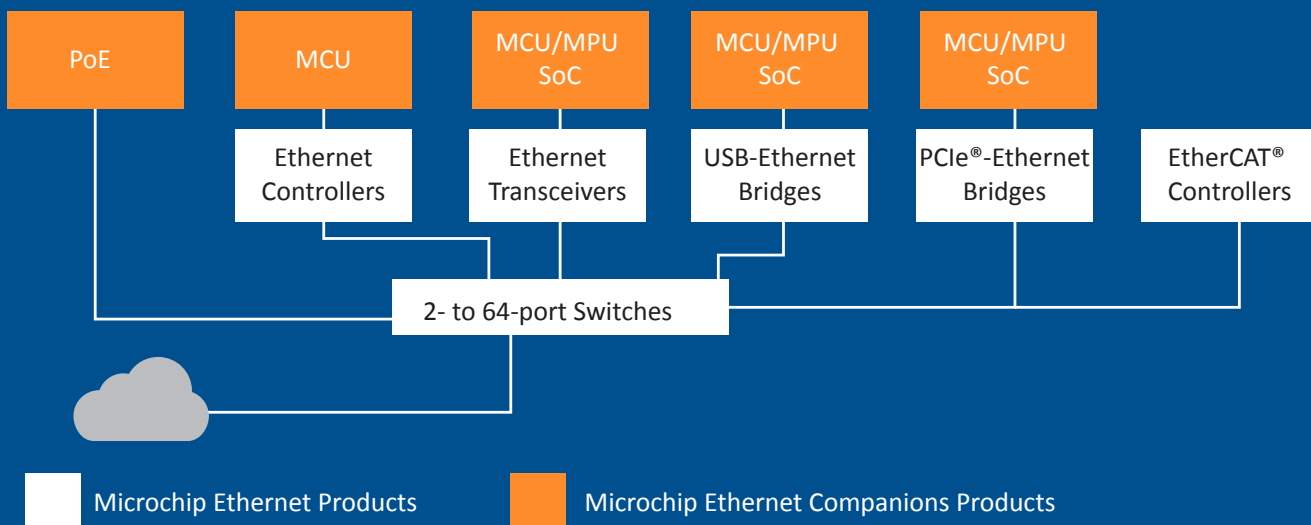

Design Check Online Design Review

Our Design Check Online Design Review services are personalized, value-added services available to our customers. Design Check will support your design process by providing guidance through the complete design cycle—from initial schematic design to PCB design. After an initial Design Check registration, you may submit the design schematic, PCB layout or PCB routing design information to a confidential and secure environment where it is analyzed by our engineers who will provide you with personalized feedback. Submit your design today at www.microchip.com/design-check-services.



Software Drivers

We develop, test and certify software drivers for MPLAB Harmony, Microsoft Windows, MacOS, Linux OS, Autosar and many proprietary stacks used in MCU-, MPU- and SoC-based systems. We include MPLAB Harmony drivers in the download of the software and they also support our starter kits, allowing you to get your application online quickly. Our Windows drivers comply with our rigorous Windows Logo Program for Hardware (WHQL), ensuring seamless operation in Windows-based systems. We submit our Linux drivers to the Linux kernel, and they are thoroughly vetted by members of the community, giving you high-quality, peer-reviewed software for your application. Visit our Embedded Software website for more information: <http://www.microchip.com/mplab/embedded-software-center> and www.microchip.com/mplab/embedded-software-center.

Our software for Ethernet switching applications provides a comprehensive set of features for enterprise, carrier and industrial designs. Customizable and turnkey solutions shorten development cycles and reduce your costs. See our website for links to software drivers: www.microchip.com/design-centers/ethernet/software.

Additional MPLAB Harmony Software

- TCP/IP stack
- WolfSSL SSL/TSL encryption library
- USB host/device stack

Supported Applications

- WebStaX
- SMBStaX
- ISTaX
- FreeRTOS

Ethernet Switch and PHY API

- ETH API

Devices With Available Drivers

- PHY transceivers
- Bridging devices
- Ethernet controllers
- Ethernet switches



Transceivers (PHYs)

Microchip's 10/100, Gigabit PHY, multi-Gigabit and multi-port options seamlessly attach to SoCs, MCUs and CPUs with industry standard interfaces (GMII, RGMII, RMII, MII). Designed with Energy-Efficient Ethernet and Wake-On-LAN, the devices lower power consumption, minimize emissions and increase immunity to noisy environments. The availability of high-temperature versions make these devices ideal for industrial and automotive applications. LinkMD®+ enables advanced diagnostics, critical to maintaining scalable network deployments. Standard Linux drivers are provided to ensure minimal code development.

Available Features

- Standard Media Access Control (MAC) interface
- Single Pair Ethernet
- On-chip termination
- Robust technology
- Energy-efficient Ethernet (802.3az)
- LinkMD+ with signal quality indicator
- MACsec
- 1588v2
- EtherCAT® Support



Ethernet PHYs

Feature	KSZ8081	KSZ8041	KSZ8051	LAN8742A	LAN8710A	LAN8770	VSC8531	KSZ9131	VSC85412
Bandwidth	10BASE-T/100BASE-TX					100BASE-T1	10/100/1000BASE-T		
Interface	MII/RMII	MII/RMII/ SMII	MII/RMII	RMII	MII/RGMII	RGMII/ MII/ RMII	RMII/ RGMII	MII/RGMII/ GMII	RMII/RGMII/ GMII
WoL	-	✓	-	✓	✓	TC10	✓	✓	✓
EEE	-	✓	-	-	✓	-	✓	✓	✓
Vdd I/O	1.8/2.5/3.3		-	1.6-3.3	1.3-3.3	1.8/2.5/3.3	1.5/1.8/ 2.5/3.3	1.8/2.5/3.3	1.5/1.8/ 2.5/3.3
LinkMD® Technology	✓	✓	✓	✓	✓	✓	✓	✓	✓
EtherCAT	✓	✓	✓	✓	✓	-	✓	✓	✓
1588v2	-	-	-	-	-	-	-	-	SoF, SyncE
Power	152 mW	<180 mW	155 mW	163 mW	158 mW	130 mW	644 mW	489 mW	644 mW
Temperature	-40 to 85°C	-40 to 85°C (AEC-Q100)	-40 to 105°C (AEC-Q100)	-40 to 85°C		-40 to 125°C (AEC-Q100)	-40 to 125°C	-40 to 105°C (AEC-Q100)	-40 to 125°C
Packages	24-pin VQFN	32-pin VQFN, 48- pin LQFP	32-pin VQFN	24-pin QFN	32-pin QFN,	32-pin VQFN, 36- pin VQFN	48-pin VQFN	48-pin VQFN, 64- pin VQFN	68-pin VQFN

Notes: 1. VSC devices maximum temperature is specified as junction temperature 2. Contact Microchip for radiation tolerant versions for aerospace applications

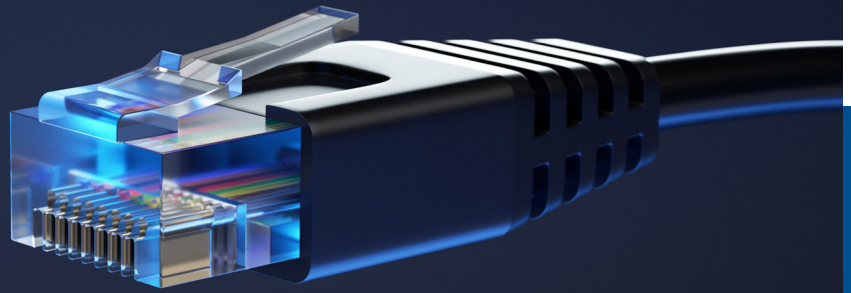

PHY Evaluation Boards

Getting started with our Ethernet PHYs is easy. Several development board options are available, from MCU/MPU boards with a specific on-board PHY, to modular development boards accommodating one of the PHY Daughter boards. Our most popular options are below but you can find a complete list of PHY evaluation boards at [HYPERLINK "http://www.microchip.com/EthernetPHY"](http://www.microchip.com/EthernetPHY)

Several development board options are available, from MCU/MPU boards with a specific on-board PHY, to modular development boards accommodating one of the PHY Daughter boards.

Development boards With On-Board PHYs

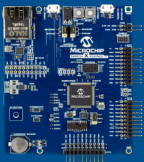

ATSAME54-XPRO

An XPro development board based on the SAM E54 high performance micro-controller series featuring a 32-bit ARM® Cortex®-M4F processor, running up to 120 MHz with the on-board KSZ8081 10/100 PHY.

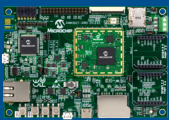

SAMA5D27 SOM1 Kit1

A development board based on the high performance 32-bit Arm Cortex-A5 SAMA5D27 System-On-Module (SOM) running up to 500 MHz with on-board KSZ8081 10/100 PHY. The SAMA5D27-SOM1 is delivered with a free Linux distribution and bare metal C code examples.

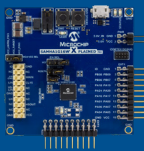

ATSAM4E-XPRO Evaluation Kit

An XPro development board based on the SAM4E featuring the ARM® Cortex®-M4 processor, running up to 120 MHz with the on-board KSZ8081 10/100 PHY.

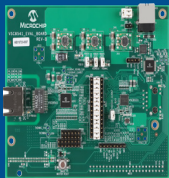

VSC8541 Evaluation Board

VSC8541EV provides a way to evaluate the VSC8541 and VSC8531 devices in multiple configurations. Two RJ-45 connectors are provided for the copper media interface from each device. The MAC interface is exposed through 0.1 inch pin-headers. For standalone access to all device features, an external microcontroller is used to configure both the VSC8541 and the VSC8531 through the MDIO bus.



EVB-LAN8770M_MC (EV02N47A)

The EVB-LAN8770M_MC is a media converter evaluation board between 100BASE-TX and 100BASE-T1 Ethernet PHY technology.



EVB-LAN8770-RMII (EV48S68A)

The EVB-LAN8770_RMII board is a 100BASE-T1 Ethernet PHY plug-in card for the SAMS70/E70/V70/V71 Xplained Ultra board.

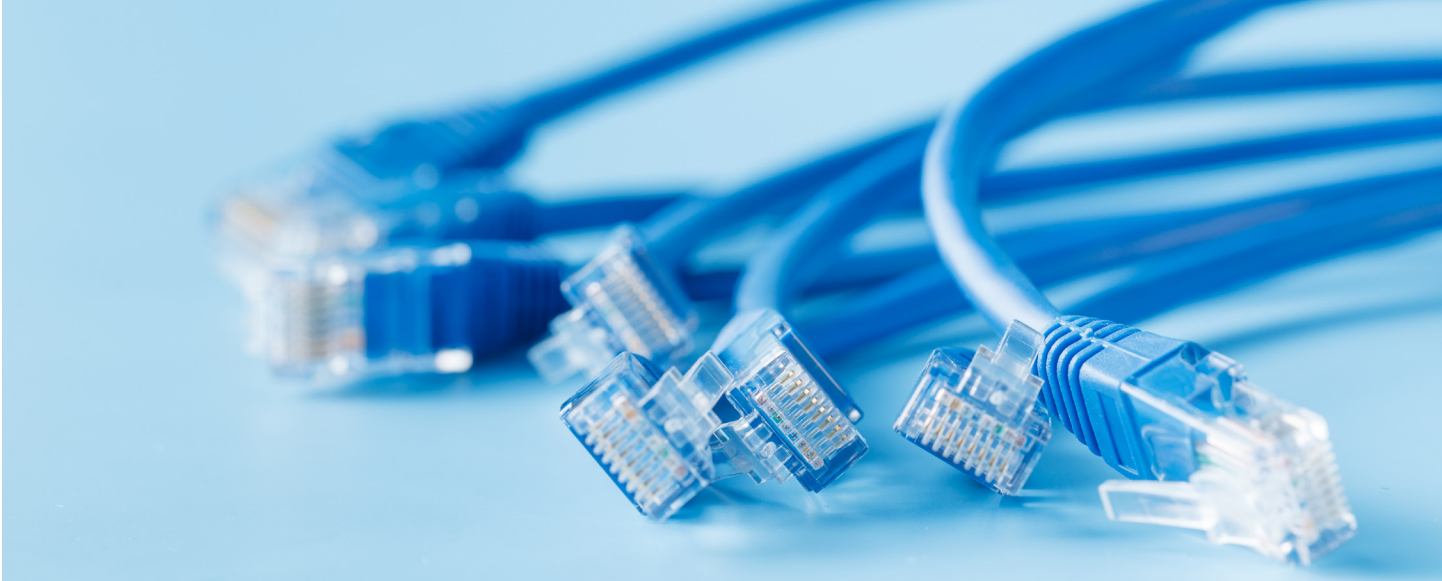

Development Boards Socketed for PHY Daughter Boards



SAM E70 Xplained Ultra Evaluation board

DM320113 The SAM E70 Xplained Ultra Evaluation Kit is a hardware platform for evaluating the ATSAME70 an Arm Cortex-M7 running at up to 300 MHz with an integrated MAC supporting any AC320004x PHY Daughter Board.



SAM E54 Curiosity Ultra Evaluation board

DM320210 is Microchip's latest generation of development platforms with high modularity. The SAME54 is based on the ARM Cortex M4 core running up to 120MHz with integrated 10/100 MAC supporting AC320004x PHY Daughter Boards.

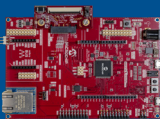

PIC32MZ EF Curiosity 2.0 Development Board

DM320209 is based on the PIC32MZ with Floating Point Unit (EF), a MIPS M5150 core running at up to 200 MHz, up to 2 MB of flash and 512 KB SRAM with a broad set of peripherals including a socket for 10/100 Ethernet PHY Daughter Boards. (KSZ8061 AC320004-6 included).

SAMA5D3 Ethernet Development System (EDS)

DM320114 is based on the SAMA5D36 Microprocessor, a high-performance, ultra-low-power ARM Cortex-A5 processor running up to 536MHz with a floating-point unit that features a Gigabit EMAC and/or 10/100 EMAC. The platform is ready for any 10/100 Daughter Board and/or an EDS Daughter boards.

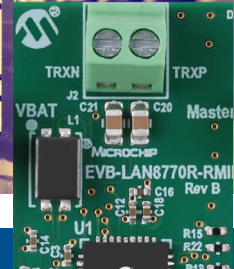

Ethernet PHY Daughter Boards

Ethernet PHY Daughter Boards enable modular development of a platform design that fits your needs. The original 10/100 Ethernet Daughter Boards were designed to plug into multiple development platforms to take advantage of MCUs with integrated 10/100 Ethernet MACs.

PHY Device	Ports	Description	Daughter Board
KSZ8041	1	10/100 PHY	AC320004-5
KSZ8061	1	10/100 PHY	AC320004-6
KSZ8863	2	10/100 PHY	AC320004-7
LAN8720	1	10/100 PHY	AC320004-3
LAN8770	1	100BASE-T1 PHY	EV48S68A
KSZ9131	1	10/100/1000 PHY	EV16T60A

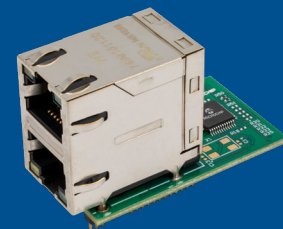

The Ethernet Development System (EDS) Daughter Boards represent Microchip's latest generation develop platform supporting 10/100/1000 Mbps Ethernet PHYs. The EDS connector that is on the bottom side of these boards delivers the performance needed for Gigabit+ PHY speeds.

For the latest Ethernet PHY Daughter board offering go to www.microchip.com/EDB



PIC32 Ethernet Starter Kit II (DM320004-2)

This kit provides the easiest and lowest-cost method to experience 10/100 Ethernet development with PIC32 MCUs. It is combined with LAN8720A and our free TCP/IP software.



KSZ9131RNX Gigabit Ethernet Evaluation Board (KSZ931RNX-EVAL)

This board features an integrated triple-speed (10Base-T/100Base-TX/1000Base-T) Ethernet physical layer transceiver for transmission and reception of data over a CAT-5 UTP cable. The KSZ9131RNX provides RGMII for direct connection to RGMII MACs.



KSZ8061MNX Evaluation Board (KSZ8061MNX-EVAL)

This board allows you to test the KSZ8061MNX PHY with Quiet-WIRE technology. Additionally, a second PHY, the KSZ8081 (10/100 Ethernet PHY), is used to provide a second-line interface for simple full-duplex traffic through the KSZ8061. This board is not intended for evaluation of the KSZ8081.



LAN8742 10/100 High-Speed Ethernet Transceiver Evaluation Board (EVB8742)

This board has a standard 40-pin MII connector for RMII configurations and supports WoL and cable diagnostics.



For SoCs and MPUs/CPU's that have USB or PCIe but no Ethernet-standard interface, we offer a portfolio of bridge devices. These devices are fully integrated with on-chip USB or PCIe and Ethernet MAC/PHYs to minimize application size and BOM costs. We provide Windows, macOS and Linux and QNX drivers to enable transparent operation and compatibility. Our Ethernet bridge devices are compatible with USB 2.0, USB 3.1 Gen1, PCIe and HSIC, delivering up to Gigabit performance.

Available Features

- Wire speed: USB 3.1 Gen1 to Ethernet
- Internal or external PHY interface
- Small 6 × 6 mm, 48-pin package
- On-chip configuration OTP memory
- Bridge USB 3.1, PCIe to 1000BASE-T1 or HDBase-T
- EEE 802.3az
- WoL and Microsoft Always On Always Connected (AOAC)
- Single Pair Ethernet (802.3bw)

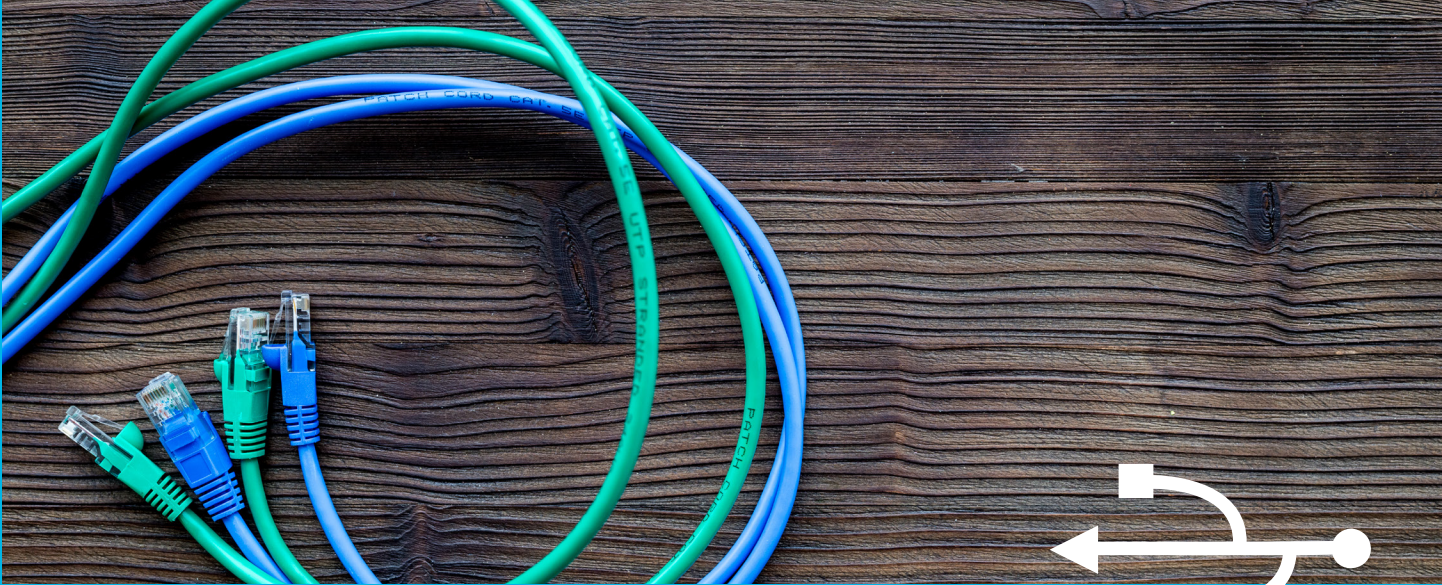

Ethernet Bridges

Feature	LAN9730	LAN9500A	LAN9512/3/4	LAN7500	LAN7850	LAN7800	LAN7801	LAN7430	LAN7431
Ethernet Bridge	HSIC to 10/100	USB 2.0 to 10/100		USB 2.0 to 10/100/1000	USB 2.0/ HSIC to 10/100/1000	USB 3.1 Gen1 to 10/100/1000	PCIe® to 10/100/1000		
Integrated Ethernet PHY	✓	✓	✓	✓	✓	✓	-	✓	-
NetDetach™ Technology	✓	✓	-	✓	✓	✓	✓	✓	✓
WoL	✓	✓	✓	✓	✓	✓	✓	✓	✓
PME Support	✓	✓	-	✓	✓	✓	✓	✓	✓
EEE	-	-	-	-	✓	✓	✓	✓	✓
IEEE® Standard 1588	-	-	-	-	-	-	-	✓	✓
Temperature	-40 to 85°C	-40 to 85°C	-40 to 85°C	-40 to 85°C	-40 to 85°C	-40 to 85°C	-40 to 105°C AEC-Q100	-40 to 105°C	-40 to 105°C, AEC-Q100
Packages	56-pin QFN		64-pin QFN	56-pin QFN	56-pin QFN	48-pin QFN	64-pin QFN	48-pin SQFN	72-pin SQFN
MAC I/F	MII and Turbo MII		-	-	-	-	RGMII	-	RMII/RGMII



Bridge Evaluation Boards

The low-cost dongle format of USB-to-Ethernet bridges makes it easy to get started. We provide a complete suite of software drivers for Linux, MacOS and Windows. Our most popular options are below but you can find a complete list of bridge evaluation boards at www.microchip.com/design-centers/ethernet/ethernet-devices/products/ethernet-bridges.



LAN7500 High-Speed USB 2.0-to-10/100/1000 Ethernet Evaluation Board (EVB-LAN7500)

This board is a fully functional, bus-powered USB-to-Ethernet solution with on-board Ethernet RJ45 and USB Type A connectors. The on-board 4K EEPROM loads the USB configuration parameters and MAC address. Software drivers for Windows, MacOS and Linux operating systems are available.



LAN7800 Super-Speed USB-to-Ethernet Low-Cost Evaluation Board (EVB-LAN7800-LC1)

With an ultra-low cost BOM, this evaluation board integrates the USB Type-C connector to implement a super-speed data transfer to Gigabit Ethernet with an on-board RJ45 connector. Linux, OS X and Windows drivers are available.

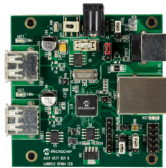

LAN9512 High-Speed USB Hub-to-Ethernet Evaluation Board (EVB9512)

This board provides a two-port USB 2.0 hub with an integrated 10/100 Ethernet controller and USB connectivity via one Type B upstream USB connector and two Type A downstream USB connectors. An RJ-45 Ethernet jack with integrated magnetics and link/activity LEDs provides 10/100 Ethernet connectivity. The board supports both bus-powered and self-powered modes of operation.

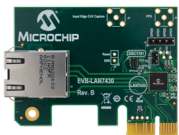

LAN7430 PCIe-to-Gigabit Ethernet Evaluation Board (EVB-LAN7430)

This board enables comprehensive evaluation of basic networking through to IEEE 1588 Precision Time Protocol (PTP). We provide connectors for access to accurate timing signals. JTAG is available via headers or mapping.



LAN9513/LAN9514 High-Speed USB 2.0 TO 10/100 Ethernet Hub Customer Evaluation Board (EVB-LAN9514)

The EVB9514 is an Evaluation Board EVB that utilizes the LAN9514 to provide a four port USB 2.0 hub with an integrated 10/100 Ethernet controller. The EVB9514 provides USB connectivity via one type B upstream USB connector and four type A downstream USB connectors. An RJ-45 integrated magnetics Ethernet jack with link/activity LEDs provides 10/100 Ethernet connectivity. The EVB9514 supports both bus-powered and self-powered modes of operation.



Switches

You can implement managed or unmanaged networks using our portfolio of 10/100, Gigabit and multi-Gigabit switches. These L2+ switches feature multiple ports, extensive advanced switch functionality and a small footprint, assuring optimal network performance. For real-time control, like Time-Sensitive Networking (TSN), our switches feature IEEE 1588 v2 PTP with nanosecond precision, traffic scheduling/shaping and path reservation.

Available Features

- Up to 25 Gbps speeds
- Audio/Video Bridging (AVB)
- Energy Efficient Ethernet IEEE802.3az
- IEEE 802.1Qav-based traffic scheduler
- IEEE 802.1X port-based authentication
- PTP (IEEE 1588 v2, IEEE802.1AS-2020)
- Network fault recovery (DLR/HSR)
- Industrial temperatures
- LinkMD+ cable diagnostics with signal quality indicator
- Synchronous Ethernet support
- Supports TSN
- Single Pair Ethernet

Ethernet Switches

Gigabit Switch Family

Feature	LAN9370	LAN9371	LAN9372	LAN9373	LAN9374	KSZ9477	KSZ956x	KSZ989x
Bandwidth	100BASE-TX/T1					10Base-T/100Base-TX/1000Base-T		
Ports	4	3	5	5	6	7	3, 7	3, 6, 7
Interface	RGMII/RMII/MII			SGMII	RGMII/RMII/MII	SGMII/RGMII/GMII/RMII/MII		
Cable Diagnostics	LinkMD®+ with signal quality indicator					LinkMD Technology	LinkMD+ with signal quality indicator	LinkMD Technology
IEEE® 1588 v2/802.1AS	✓	✓	✓	✓	✓	✓	✓	-
AVB	✓	✓	✓	✓	✓	✓	✓	-
TSN	✓	✓	✓	✓	✓	✓	✓	-
Time Aware Scheduler	✓	✓	✓	✓	✓	✓	✓	-
Low-Latency Cut-Through	✓	✓	✓	✓	✓	✓	✓	-
Network Fault Recovery (DLR/HSR)	✓	✓	✓	✓	✓	✓	-	-
EEE/WoL/TC10	✓	✓	✓	✓	✓	✓	✓	✓
Temperature	-40 to 105°C AEC-Q100					-40 to 85°C		
Packages	64-pin QFN	128-pin TQFP	128-pin TQFP	128-pin TQFP	128-pin TQFP	128-pin TQFP	64-pin QFN, 128-pin LQFP, 128-pin TQFP	64-pin QFN, 128-pin LQFP, 128-pin TQFP

Microchip offers an extensive line of Fast Ethernet switches to meet a variety of consumer, industrial and automotive needs. The following are just a portion of the entire portfolio. For the complete portfolio, please go to

<http://www.microchip.com/design-centers>

www.microchip.com/design-centers/ethernet/ethernet-devices/products/ethercat

<https://www.microchip.com/en-us/products/high-speed-networking-and-video/ethernet/ethernet-switches>



3-Port Switches

Feature	KSZ8863	KSZ8873	KSZ8463	KSZ8563	LAN9303	LAN9353	LAN9355
Bandwidth	10Base-T/100Base-TX/100Base-FX			10Base-T/100Base-TX		10Base-T/100Base-TX/100Base-FX	
Interface	MII/RMII			MII/RMII/RGMII	MII/RMII/ Turbo MII	SPI/SQI/RMII/MII	MII
EEE	-	-	✓	✓	-	✓	✓
V_{DD} I/O	1.8/2.5/3.3				3.3	1.6-3.3	
Cable Diagnostics	✓	✓	✓	✓	-	✓	✓
IEEE® 1588	-	-	✓	✓	-	✓	✓
Power	520 mW		330 mW	-	640 mW	555 mW	
Temperature	-40 to 85°C	-40 to 85°C (AEC-Q100)		-40 to 105°C (AEC-Q100)	-40 to 85°C		
Packages	48-pin LQFP	64-pin LQFP		64-pin QFN	56-pin QFN	64-pin QFN, 64-pin TQFP-EP	88-pin QFN, 80-pin TQFP-EP

Switches









4-Port to 9-Port Switches: KSZ Models

Feature	KSZ8864	KSZ8895	KSZ8794	KSZ8795	KSZ8775	KSZ8765	KSZ8565	KSZ8567	KSZ8999
Bandwidth	10/100Base-T/TX, 100Base-FX		10/100Base-T/TX with GigE Uplink			10/100BASE-T/TX, 100BASE-FX with GigE Uplink	10/100BASE-T/TX with GigE Uplink		10/100BASE-T/TX, 100BASE-FX
Number of Ethernet Ports	4	5	4	5			7		9
Interface	MII/RMII (×2)		RGMIIMII/RMII	GMII/RGMII MII/RMII	RGMIIMII/RMII	GMII/RGMII MII/RMII	RGMIIMII/RMII	RGMIIMII/RMII/SGMII	MII, SNI
EEE/WoL	-	-	✓	✓	✓	✓	✓	✓	-
IEEE® 802.1X	-	-	-	-	-	-	✓	✓	-
V_{DD} I/O	1.8/2.5/3.3								3.3
LinkMD® Technology	✓	✓	✓	✓	✓	✓	LinkMD+ with signal quality indicator		-
Power	253 mW	435 mW	430 mW	560 mW	460 mW	560 mW	-	-	1472 mW
Temperature	-40 to 85°C (AEC-Q100)		-40 to 85°C				-40 to 105°C (AEC-Q100)	-40 to 105°C (AEC-Q100)	-40 to 85°C
Packages	64-pin QFN	128-pin LQFP	64-pin QFN	80-pin LQFP			128-pin TQFP		208-pin PQFP

4-Port to 64-Port Switches: VSC Models

Features	VSC7511	VSC7512	VSC7513	VSC7514	VSC7440	VSC7448	VSC7449	VSC7546TSN	VSC7549TSN
Bandwidth	10/100/1000/2500 Mbps	10/100/1000/2500 Mbps	10/100/1000/2500 Mbps	10/100/1000/2500 Mbps	10/100/1000/2500 Mbps 10 Gbps	10/100/1000/2500 Mbps 10 Gbps	10/100/1000/2500 Mbps 10 Gbps	10/100/1000/2500 Mbps 5/10 Gbps	10/100/1000/2500 Mbps 5/10 Gbps
Ports	4	10	8	10	10	52	52	64	64
Interface	SGMII 1000Base-T (4)	SGMII, QSGMII 1000Base-T (4)	SGMII, QSGMII 1000Base-T (4)	SGMII, QSGMII 1000Base-T (4)	SGMII 1000Base-T XFI	SGMII, QSGMII XFI, XAUI, RXAUI	SGMII, QSGMII XFI, XAUI, RXAUI	SGMII, QSGMII, USGMII, USXGMII, XFI	SGMII, QSGMII, USGMII, USXGMII, XFI
EEE	✓	✓	✓	✓	-	✓	✓	✓	✓
TSN	-	-	-	-	-	-	-	✓	✓
V_{DD} I/O (V)	1.0/1.2/2.5	1.0/1.2/2.5	1.0/1.2/2.5	1.0/1.2/2.5	1.0/1.2/2.5	1.0/1.2/ 2.5/3.3	1.0/1.2/ 2.5/3.3	0.9/1.5/ 1.8/3.3	0.9/1.5/ 1.8/3.3
Cable Diagnostics	✓	✓	✓	✓	✓	✓	✓	-	-
IEEE 1588	✓	✓	✓	✓	✓	-	-	✓	✓
Temperature	-40 to 125°C	-40 to 125°C	-40 to 125°C	-40 to 125°C	-40 to 125°C	-40 to 110°C	-40 to 110°C	-40 to 110°C	-40 to 110°C
Packages	172 VQFN	172 VQFN	256 PBGA	256 PBGA	172 VQFN	672 pins	672 pins	888 FCBGA	888 FCBGA

Development Tools

	Development Tool	Part Number	Description
	Add-On for EL9800 Development Platform	EVB-LAN9252-ADD-ON	This is designed to be used as an add-on board (ESC board) with the Beckhoff EL9800 EtherCAT® Evaluation Board. This board supports the SPI and DIGIO PDI modes of the LAN9252.
	Pictail™ Plus for Explorer 16 Platform	EVB-LAN9252-PICTAIL	This board is used to evaluate the LAN9252. It is an expansion board for the Explorer 16 Development Board (DM240001).
	3-Port EtherCAT Slave Controller Evaluation Kit with SPI PDI Interface	EVB-LAN9252-3PORT	This evaluation board is a stand-alone platform with SPI/SQI as the PDI interface. It supports the on-board PIC32MX or options for other SoCs.
	4-Port Slave Controller Evaluation Kit in Expansion Mode	EVB-LAN9252-4PORT	This board features a unique design by cascading two LAN9252 ESCs in a back-to-back configuration through the MII interface. It is a stand-alone platform to develop an EtherCAT slave device with SPI/SQI™ as the PDI interface. This board supports the on-board PIC32MX or options for other SoCs.
	EtherCAT Slave Controller Evaluation Kit with DIGIO PDI Interface	EVB-LAN9252-DIGIO	This board satisfies the demand for hardware-only EtherCAT slave devices. The exposed DIGIO interface can operate together with control signals without an attached MCU.
	EtherCAT Slave Controller Evaluation Kit with HBI PDI Interface	EVB-LAN9252-HBIPLUS	This board is a stand-alone platform to develop an EtherCAT slave device with PIC32 or other SoCs/MCUs/MPUs with more advanced features over the standard HBI board.
	EVB-LAN9255	EV25Y25A	EVB-LAN9255 allows engineers to develop using an integrated Cortex M4F microcontroller and EtherCAT device controller. Peripherals are provided on board with expansion via the popular mikroBUS Click Board™ interface. An ethernet MAC is available and allows connection to associated boards for single and dual port options. This hardware is fully supported within the Microchip Harmony Framework.
	EVB-LAN9253 D51 EVB-LAN9253 Ethercat Device Controller Evaluation Kit With SAMD51 Microcontroller	EV50P30A	VB-LAN9253-D51 allows engineers to develop using the LAN9253 ESC together with a Cortex M4F Microcontroller. Peripherals are provided on board with expansion via the popular mikroBUS Click Board™ interface. This hardware is fully supported within the Microchip Harmony Framework. An identical board is available that carries LAN9252. Between these two platforms a user can observe pin compatibility and a migration path from LAN9252 towards LAN9253.
	EtherCAT controller with dual integrated Ethernet PHYs	LAN9254	Microchip's LAN9254 is a 3 port EtherCAT device controller (ESC) with dual integrated Ethernet PHYs which each provide a full-duplex 100BASE-TX transceiver and support 100Mbps (100BASE-TX) operation. The LAN9253 supports HP Auto-MDIX, allowing the use of direct connect or cross-over LAN cables. This device provides system developers a cost-effective solution for realizing EtherCAT device solutions.

Find out more at www.microchip.com/ethercat.

Switch Evaluation Boards

You can implement Ethernet networks with ease by starting with our switch evaluation boards. For development in MPLAB Harmony software framework, select the PIC32 Starter Kit for Ethernet II and the LAN9303 daughter card. For development with processors running Linux OS, choose from our evaluation boards with standard MAC interfaces. Our most popular options are below, but you can find a complete list of switch evaluation boards at www.microchip.com/design-centers/ethernet/ethernet-devices/products/ethernet-switches.



LAN9303 PHY Switch Daughter Board (AC320004-4)

Used with the PIC32 Ethernet Starter Kit II, this board provides an easy and low-cost way to implement 10/100 Ethernet switching. Combined with our free TCP/IP software, this kit gets your project running quickly.

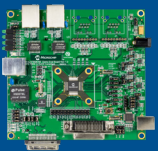

KSZ8765 10/100 Ethernet Evaluation Board (KSZ8765CLX-EVAL)

This board features an integrated 5-port switch with Gigabit up-link. It contains four MAC/PHYs with two fiber ports, two copper ports and one GMAC interface that is configurable with GMII/RGMII/MII/RMII interfaces. We designed this board to allow Gigabit up-link with the Gigabit port of any processor.

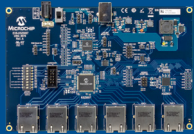

KSZ9897 Gigabit Ethernet Evaluation Board (EVB-KSZ9897)

This board features a completely integrated triple speed (10Base-T/100BASE-TX/1000Base-T) Ethernet switch with seven ports. The board has six physical ports and one USB-to-Ethernet port. The board also features the LAN7800 USB-to-Ethernet bridge and KSZ9031 Gigabit PHY.



KSZ9477 Gigabit Ethernet Evaluation Board (EVB-KSZ9477)

This board features a completely integrated triple speed (10Base-T/100-Base-TX/1000Base-T) Ethernet switch with five ports and one SFP port. The Arm[®]-based ATSAMA5D3 host processor implements advanced switch management features such as IEEE 1588 v2, HSR/DLR ring redundancy, AVB and authentication and it is also reprogrammable.

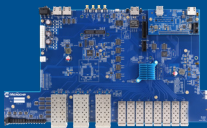

VSC5640EV SPARX-5,-5I Evaluation Board, 12 SFP 8 SFP28

The VSC5640EV ethernet development system can be used to demonstrate the SparX-5,-5i Ethernet switches.



VSC5634EV - Ocelot, Elise, 8XRJ45, 2XSFP, Unmanaged Reference Board

The VSC5634EV ethernet development system can be used to demonstrate the VSC7511/12 Ocelot unmanaged Ethernet switches and the VSC8514 PHY devices.



VSC7514EV - Ocelot, 8XRJ45, 8XSFP, PTP, SyncE, Managed Reference Board

This is the evaluation board for the VSC7514 10-Port Gigabit Ethernet Switch (and the VSC7513).

EVB-LAN9370 (EV64C55A)

The EVB-LAN9370 board is a 100BASE-T1 Ethernet switch plug-in card for the SAMS70/E70/V70/V71 Xplained Ultra board.

Controllers

For embedded applications, like those using MCUs, our Ethernet controller family offers many flexible interfaces, including SPI, PCI and 8-/16-/32-bit parallel host bus interfaces. All of these interfaces work with an integrated MAC and PHY, delivering 10/100 performance with minimal CPU overhead. We offer free compact TCP/IP stacks for 8-, 16- and 32-bit MCUs. Our Ethernet controllers are also available in small package options.

Available Features

- Variety of flexible processor interfaces
- Small 5 × 5 mm 32-pin packaging
- IEEE 1588 v2 PTP
- Hardware AES encryption engine
- Energy Efficient Ethernet (EEE) (802.3az)

Ethernet Controllers

We provide drivers for our award-winning MPLAB Harmony software framework and for open operating systems like Linux. Whether your application is large or small, we have the driver to cover your needs.

Feature	ENC28J60	ENC624J600	KSZ8851	LAN9250	LAN9221	KSZ8441	KSZ8462
Bandwidth	10Base-T	10/100Base-T/TX	10/100Base-T/TX, 100Base-FX	10/100Base-T/TX		10/100Base-T/TX, 100Base-FX	
TX/RX Buffer	8 KB	24 KB	12 KB (RX), 6 KB (TX)	16 KB		12 KB (RX), 6 KB (TX)	
Interface	SPI	SPI, Parallel	SPI, 8-/16-bit, 16-/32 bit	SPI, 16-bit	16-bit	8-/16-bit	
IEEE® 1588 v2	-	-	-	✓	-	✓	✓
WoL	-	-	✓	✓	-	-	-
EEE 802.3az	-	✓	✓	✓	-	✓	✓
Number of Ports	1	1	1 or 2	1	1	1	2
Cable Diagnostics	-	-	✓	✓	-	✓	✓
Power	790 mW	416 mW	330 mW	344 mW	522 mW	330 mW	
Temperature	-40 to 85°C		-40 to 85°C (AEC-Q100)	-40 to 85°C			
Packages	28-pin QFN, 28-pin SOIC 300 mil, 28-pin SPDIP, 28-pin SSOP 208 mil	48-pin QFN, 48-pin TQFP, 64-pin TQFP	32-pin QFN, 48-pin LQFP, 128-pin PQFP	56-pin VQFN		64-pin LQFP	

Controller Evaluation Boards

Adding an Ethernet controller to your application is easy. The Ethernet PICtail™ Plus daughter board used with the Explorer 16 is an ideal solution for your PIC24- and PIC32-based applications. For development in the MPLAB Harmony software framework, select the LAN9250 10/100 Ethernet Controller Evaluation Board. For development with processors running the Linux OS, the KSZ8851SNL evaluation board provides SPI-to-Ethernet connectivity. Our most popular options are below but you can find a complete list at www.microchip.com/design-centers/ethernet/ethernet-devices/products/ethernet-controllers.



Ethernet PICtail Plus Daughter Board (AC164123)

Designed for flexibility while evaluating and developing Ethernet control applications, you can plug this board into our Explorer 16 (DM240001) and use it with our TCP/IP stack to connect with any of our 16-bit MCUs.



KSZ8851SNL Evaluation Board (KSZ8851SNL-EVAL)

This board is for the evaluation of this single-port Ethernet controller. With a 32-pin QFN (5 × 5 mm) package, it is ideal for applications requiring SPI and provides a basic software driver and configuration utility.

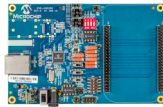

LAN9250 10/100 Ethernet Controller Evaluation Board (EVB-LAN9250)

The simple yet highly functional host bus interface provides a glue-less connection to the most common MPUs and MCUs and you can access the device via SPI/SQI. You can also fit an optical fiber interface via an SFP module. You can interface the on-board PIC32MX MCU to the LAN9250 using an HBI or SPI interface.



EtherCAT®

Microchip's LAN9252 is a 2/3-port EtherCAT device controller (ESC) with dual integrated Ethernet PHYs which each contain a full-duplex 100BASE-TX transceiver and support 100Mbps (100BASE-TX) operation. The LAN9252 supports HP Auto-MDIX, allowing the use of direct connect or cross-over LAN cables. 100BASE-FX is supported via an external fiber transceiver. This device provides system developers a cost-effective solution for realizing EtherCAT device solutions.

Available Features

- Operates with/without host processor
- Fast SPI, quad SPI or 8-/16-bit interfaces
- Multi-function GPIO
- Compact 12 × 12 mm 64-pin package
- Flexible operation modes with up to three ports
- Integrated microcontroller

Product Features	LAN9252	LAN9253	LAN9254	LAN9255
EtherCAT Ports				
Number of ports available	1,2,3, 4*	1,2,3,4*	1,2,3,4*	1,2,3,4*
Number of PHY available	2 PHY, 1 MII**	2 PHY, 1 MII**	2 PHY, 1 MII**	2 PHY, 1 MII**
Integrated MCU	-	-	-	✓
Integrated Arm® Cortex®-M4F MCU	-	-	-	✓
10/100 Ethernet MAC (RMII)	-	-	-	✓
Process Data Interface (PDI)				
SPI/SQI	✓	✓	✓	✓
Link status LED	✓	✓	✓	✓
EtherCAT Error LED		✓	✓	✓
EEPROM				
EEPROM size (in bits)	1K to 4M	1K to 4M	1K to 4M	1K to 4M
EEPROM emulation	-	✓	✓	✓
Fibre support	✓	-	-	-
Auto MDIX	✓	✓	✓	✓
EtherCAT Wake Up	✓	✓	✓	✓
Power Over EtherCAT (EtherCAT P)	✓	✓	✓	✓
Target cycle time	125 µSec	76.9 µSec	76.9 µSec	76.9 µSec
Package	64 QFN, 64 TQFP	64 QFN	80 TQFP	128 TQFP
Extended Industrial Version	-40 to +105°C	-40 to +105°C	-40 to +105°C	-40 to +105°C



Ethernet Companion Processors

We have over 150 PIC® MCUs and SAM Arm MCU/MPUs with Ethernet MAC to support networking applications. Options range from fully integrated PIC MCUs plus 10Base-T MAC/PHY to MPUs with on-board 10/100/1000 MAC interfacing to external PHYs or switches.





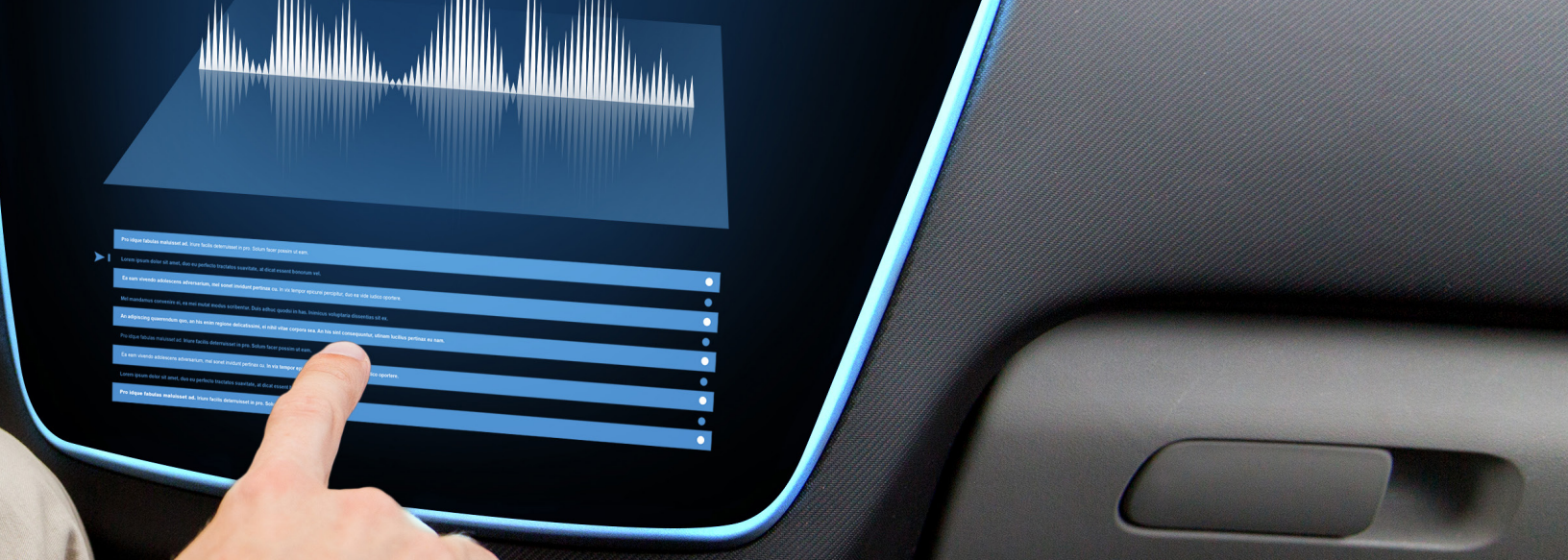

Ethernet Companion Processors

- PIC18 with on-board MAC/PHY
- Over 90 PIC MCUs with on-board MAC
- Over 40 SAM 32-bit Arm MCUs with on-board 10/100 MAC
- Over 15 SAM A5/Arm9 32-bit Arm MPUs with on-board 10/100 or Gigabit MAC



We provide a free TCP/IP stack for our PIC and SAM Arm-based MCUs/MPUs. In addition, we provide Ethernet drivers for the MPLAB Harmony software framework and for open operating systems like Linux OS.

Development Tools

	Development Tool	Part Number	Description
	PIC32 Ethernet Starter Kit II	DM320004-2	This board provides an easy and low-cost method to experience 10/100 Ethernet development with PIC32 MCUs. Combined with our free TCP/IP software, this kit gets your project running quickly. Features include a socket accommodating various 10/100 Ethernet transceiver (RJ-45) PHY daughter boards.
	SAME70 Xplained Evaluation Kit	ATSAM70-XPLD	Featuring the KSZ8081 10/100 Ethernet PHY, this board is ideal for evaluating and prototyping fast Ethernet for consumer and industrial applications. The MCU is a ATSAME70Q21 Arm® Cortex®-M7 MCU with on-board debugger. Expansion boards can be purchased separately.
	SAM V71 Xplained Ultra Evaluation Kit	ATSAMV71-XULT	Featuring the KSZ8061 10/100 Ethernet PHY with Quiet-WIRE® technology, this board is ideal for evaluating Ethernet for harsh-environment applications. The MCU is an ATSAMV71Q21 Arm Cortex-M7 with on-board debugger. Extension boards can be purchased separately.
	SAM A5 D3 Xplained	ATSAMA5D3-XPLD	Featuring the KSZ9031 Gigabit PHY and the KSZ8081 10/100 Ethernet PHY, this board supports fast prototyping and evaluation of 10/100 and Gigabit Ethernet microprocessor-based designs. It includes a rich set of connectivity and storage peripherals with expansion headers for customization, as well as a Linux® OS distribution and software package. You can power and debug with the on-board USB connector.
	KSZ9567 Gigabit Ethernet Evaluation Board	EVB-KSZ9477	This board features a completely integrated triple-speed (10BASE-T/100Base-TX/1000Base-T) Ethernet switch featuring five ports and one SFP port. The Arm-based ATSAMV71Q21 host processor implements advanced switch management features such as IEEE® 1588 v2, AVB and authentication and it is reprogrammable.
	PIC32MZ with FPU (With/Without Crypto Engine) Embedded Connectivity Starter Kit	DM320007 (Without Crypto Engine) DM320007-C (With Crypto Engine)	Featuring the LAN8740 10/100 PHY, the PIC32MZ with FPU Embedded Connectivity Starter Kit provides a low-cost method for the development and testing of USB- and Ethernet-based applications with PIC32MZ EF family devices.

Our Ethernet Solutions

Product	Bandwidth	Ports	Interface (Upstream)	1588 v2	Cable Diagnostics	100 Fx	Temperature	AEC-Q100	Packages
EtherCAT® Controllers									
LAN9252	10/100	2/3	SPI, SQI™, 8-/16-/32-bit host bus	Clock Sync.	✓	✓	-40°C to +85°C	-	64-pin QFN, 64-pin TQFP-EP
Ethernet Switches									
LAN9303	10/100	3	MII/RMII/Turbo MII	-	-	✓	-40°C to +85°C	-	56-pin QFN, 72-pin QFN
LAN9352	10/100	2	SPI/SQI/HBI	✓	✓	-	-40°C to +85°C	-	72-pin QFN, 80-pin TQFP-EP
LAN9353	10/100	3	MII/RMII/Turbo MII	✓	✓	✓	-40°C to +85°C	-	64-pin QFN, 64-pin TQFP-EP
LAN9354	10/100	3	RMII	✓	✓	✓	-40°C to +85°C	-	56-pin QFN
LAN9355	10/100	3	MII/RMII/Turbo MII	✓	✓	✓	-40°C to +85°C	-	64-pin QFN, 64-pin TQFP-EP
KSZ8463	10/100	3	MII/RMII	✓	✓	✓	-40°C to +85°C	-	64-pin LQFP
KSZ8563	10/100	3	MII/RMII/RGMII	✓	✓	-	-40°C to 105°C	✓	64-pin VQFN
KSZ8565	10/100	5	MII/RMII/RGMII	✓	✓	-	-40°C to 105°C	✓	128-pin TQFP
KSZ8567	10/100	7	MII/RMII/RGMII/SGMII	✓	✓	with SGMII	-40°C to 105°C	✓	128-pin TQFP
KSZ8765	10/100	5	MII/GMII/RGMII	-	✓	✓	-40°C to +85°C	-	64-pin QFN, 80-pin LQFP
KSZ8775	10/100	5	MII/GMII/RGMII	-	✓	-	-40°C to +85°C	-	80-pin LQFP
KSZ8794	10/100	4	MII/GMII/RGMII	-	✓	-	-40°C to +85°C	-	64-pin VQFN
KSZ8795	10/100	5	GMII/RGMII/MII/RMII	-	✓	-	-40°C to +85°C	-	80-pin LQFP
KSZ8863	10/100	3	MII/RMII	-	✓	✓	-40°C to +85°C	-	48-pin LQFP
KSZ8864	10/100	4	MII/RMII	-	✓	-	-40°C to 105°C	✓	64-pin VQFN
KSZ8873	10/100	3	MII/RMII	-	✓	✓	-40°C to 105°C	✓	64-pin VQFN
KSZ8895	10/100	5	MII/RMII	-	✓	-	-40°C to +85°C	✓	128-pin LQFP
LAN9370	Gigabit	5	RGMII/ MII/RMII	✓	✓	-	-40°C to 105°C	✓	64-pin QFN
LAN9371									
LAN9372									
LAN9373									
LAN9374									
KSZ9477	Gigabit	7	SGMII/RGMII/MII/RMII	1588 + AVB +HDR/DLR	LinkMD+ with signal quality indicator	with SGMII	-40°C to +85°C	-	128-pin LQFP
KSZ9563	Gigabit	3	SGMII/RGMII/MII/RMII	1588 + AVB	LinkMD+ with signal quality indicator	with SGMII	-40°C to +85°C	-	64-pin QFN, 128-pin LQFP
KSZ9567	Gigabit	7	SGMII/RGMII/MII/RMII	1588 + AVB	LinkMD+ with signal quality indicator	with SGMII	-40°C to +85°C	-	128-pin TQFP-EP
KSZ9893	Gigabit	3	SGMII/RGMII/MII/RMII	-	✓	-	-40°C to +85°C	-	64-pin QFN, 128-pin LQFP
KSZ9896	Gigabit	6	RGMII/GMII/MII/RMII	-	✓	-	-40°C to +85°C	-	128-pin TQFP
KSZ9897	Gigabit	7	RGMII/SGMII/MII/RMII	-	✓	with SGMII	-40°C to +85°C	-	128-pin TQFP
VSC7511	10/100/1000/2500 Mbps	4	SGMII 1000BASE-T (4)	-	✓	100FX, 1000X	-40°C to +125°C	-	172-pin VQFN
VSC7512	10/100/1000/2500 Mbps	10	SGMII, QSGMII 1000BASE-T (4)	-	✓	100FX, 1000X	-40°C to +125°C	-	172-pin VQFN
VSC7513	10/100/1000/2500 Mbps	8	SGMII, QSGMII 1000BASE-T (4)	✓	✓	100FX, 1000X	-40°C to 125°C	-	256-pin PBGA
VSC7514	10/100/1000/2500 Mbps	10	SGMII, QSGMII 1000BASE-T (4)	✓	✓	100FX, 1000X	-40°C to +125°C	-	256-pin PBGA
VSC7420	10/100/1000/2500 Mbps	10	SGMII 1000BASE-T (8)	-	✓	100FX, 1000X	-40°C to +125°C	-	672-pin HSBGA
VSC7421	10/100/1000/2500 Mbps	17	SGMII, QSGMII 1000BASE-T (12)	-	✓	100FX, 1000X	-40°C to +125°C	-	672-pin HSBGA
VSC7422	10/100/1000/2500 Mbps	25	SGMII, QSGMII 1000BASE-T (12)	-	✓	100FX, 1000X	-40°C to +125°C	-	672-pin HSBGA

Our Ethernet Solutions (Continued)

Product	Bandwidth	Ports	Interface (Upstream)	1588v2	WoL	EEE	Temperature	AEC-Q100 Auto	Packages
Ethernet Switches									
VSC7423	10/100/1000/ 2500 Mbps	7	SGMII 1000BASE-T (5)	✓	✓	100FX, 1000X	-40°C to +125°C	-	672-pin HSBGA
VSC7424	10/100/1000 Mbps	10	SGMII 1000BASE-T (8)	-	✓	100FX, 1000X	0°C to 125°C	-	672-pin HSBGA
VSC7425	10/100/1000 Mbps	18	SGMII, QSGMII 1000BASE-T (12)	-	✓	100FX, 1000X	0°C to 125°C	-	672-pin HSBGA
VSC7426	10/100/1000 Mbps	24	QSGMII 1000BASE-T (12)	-	✓	-	0°C to 125°C	-	672-pin HSBGA
VSC7427	10/100/1000 Mbps	26	SGMII, QSGMII 1000Base-T (12)	-	✓	100FX, 1000X	0°C to 125°C	-	672/HSBGA
VSC7440	10/100/1000/ 2500 Mbps 10 Gbps	10	SGMII 1000Base-T XFI	✓	✓	100FX, 1000X, SFI	-40°C to +125°C	-	324/PBGA
VSC7448	10/100/1000/ 2500 Mbps 10 Gbps	52	SGMII, QSGMII XFI, XAUI, RXAUI	✓	-	100FX, 1000X, SFI	-40°C to +110°C	-	672/HFCBGA
VSC7449	10/100/1000/ 2500 Mbps 10 Gbps	52	SGMII, QSGMII XFI, XAUI, RXAUI	✓	-	100FX, 1000X, SFI	-40°C to +110°C	-	672/HFCBGA
VSC7546	10/100/1000/2500 Mbps 5/10 Gbps	64		-			0 to 105°C		
VSC7546TSN	10/100/1000/2500 Mbps 5/10 Gbps	64		✓			-40 to 110°C		
VSC7549	10/100/1000/2500 Mbps 5/10 Gbps	64		-			0 to 105°C		
VSC7549TSN	10/100/1000/2500 Mbps 5/10 Gbps	64		✓			-40 to 110°C		
VSC7552	10/100/1000/2500 Mbps 5/10/25 Gbps	64		-			0 to 105°C		
VSC7552TSN	10/100/1000/2500 Mbps 5G/10G/25 Gbps	64		✓			-40 to 110°C		
VSC7556	10/100/1000/2500 Mbps 5/10/25 Gbps	64		-			0 to 105°C		
VSC7556TSN	10/100/1000/2500 Mbps 5/10/25 Gbps	64		✓			-40 to 110°C		
VSC7558	10/100/1000/2500 Mbps 5/10/25 Gbps	64		-			0 to 105°C		
VSC7558TSN	10/100/1000/2500 Mbps 5/10/25 Gbps	64		✓			-40 to 110°C		
Ethernet Controllers									
ENC28J60	10	1	SPI	-	-	-	-40°C to +85°C	-	28-pin SPDIP, SSOP, SOIC, QFN
ENC624J600	10/100	1	SPI/Parallel	-	-	-	-40°C to +85°C	-	24-pin TQFN, QFN, 64-pin TQFN
LAN9217	10/100	1	16-bit Host Bus/MII	-	-	-	-	-	100-pin TQFP
LAN9218	10/100	1	32-bit Host Bus	-	-	-	-40°C to +85°C	-	100-pin TQFP
LAN9220/1	10/100	1	16-bit Host Bus	-	-	-	-40°C to +85°C	-	56-pin QFN
LAN9250	10/100	1	SPI, SQI™, HBI	-	✓	✓	-40°C to +85°C	-	64-pin QFN, 64- pin TQFP-EP
LAN9420	10/100	1	32-bit PCI 3.0	-	-	-	-40°C to +85°C	-	128-pin VTQFP
LAN89218	10/100	1	32-bit Host Bus	-	-	-	-40°C to +105°C	✓	100-pin TQFP

Our Ethernet Solutions (Continued)

Product	Bandwidth	Ports	Interface (Upstream)	1588v2	WoL	EEE	Temperature	AEC-Q100 Auto	Packages
Ethernet Controllers									
KSZ8851	10/100	1	8-/16-/32-bit or SPI	-	✓	-	-40°C to +105°C	✓	32-pin QFN, 48-pin LQFP, 128-pin PQFP
KSZ8852	10/100	1	8-/16-/32-bit	-	✓	✓	I	-	64-pin LQFP
KSZ8441	10/100	1	8-/16-/32-bit or SPI	-	✓	✓	I	-	64-pin LQFP
USB to Ethernet									
LAN9500A	10/100	1	USB 2.0	-	✓	-	-40°C to +85°C	-	56-pin QFN
LAN9730	10/100	1	USB 2.0 (HSIC)/MII	-	-	-	-40°C to +85°C	-	56-pin QFN
LAN9512/13/14	10/100	1	USB 2.0	-	-	-	-40°C to +85°C	-	64-pin QFN
LAN89530	10/100	1	USB 2.0	-	✓	-	-40°C to +85°C	✓	56-pin QFN
LAN89730	10/100	1	HSIC	-	✓	-	-40°C to +85°C	✓	56-pin QFN
LAN7500	Gigabit	1	USB 2.0	-	✓	-	-40°C to +85°C	-	56-pin QFN
LAN7800/01/50	Gigabit	1	USB 3.1/USB 2.0/HSIC	-	✓	✓	-40°C to +105°C	✓	48-pin SQFN, 64-pin SQFN, 66-pin SQFN

Our Ethernet Solutions (Continued)

Product	Bandwidth	Ports	Interface (Upstream)	1588v2	WoL	EEE	Temperature	AEC-Q100 Auto	Packages
PCIe® to Ethernet									
LAN7430	Gigabit	1	PHY	-	✓	✓	-40°C to +105°C	-	48-pin QFN
LAN7431	Gigabit	1	MII/RGMII	-	✓	✓	-40°C to +105°C	✓	72-pin QFN
Ethernet Transceivers (PHYs)									
LAN8710A	10/100	1	MII/RMII	-	-	-	-40°C to +85°C	-	32-pin QFN
VSC8491-17		1		<4 ns					
VSC8254-01		2		<4 ns					
VSC8489-02		2							
VSC8489-17		2		<4 ns					
VSC8490-17		2		<4 ns					
VSC8257-01		4		<4 ns					
VSC8258-01		4		<4 ns					
LAN8720A	10/100	1	RMII	-	-	-	-40°C to +85°C	-	24-pin QFN
LAN8740A	10/100	1	MII/RMII	-	✓	✓	-40°C to +85°C	-	32-pin QFN
LAN8741A	10/100	1	MII/RMII	-	-	✓	-40°C to +85°C	-	32-pin QFN
LAN8742A	10/100	1	RMII	-	✓	-	-40°C to +85°C	-	24-pin QFN
LAN88730	10/100	1	MII/RMII	-	-	-	-40°C to +105°C	✓	32-pin QFN
KSZ8051	10/100	1	MII/RMII	-	-	-	-40°C to +105°C	✓	32-pin QFN
KSZ8061	10/100	1	MII/RMII	-	✓	-	-40°C to +105°C	✓	32-/48-pin QFN
KSZ8081	10/100	1	MII/RMII	-	-	-	-40°C to +85°C	-	24-/32-pin QFN, 48-pin LQFP
KSZ8091	10/100	1	MII/RMII	-	✓	✓	-40°C to +85°C	-	24-/32-pin QFN, 48-pin LQFP
LAN8770	Gigabit	1	RGMII/ MII/RMII	-	✓	✓	-40°C to +125°C	✓	32-/36-pin VQFN
LAN8810	Gigabit	1	GMII	-	-	-	-40°C to +85°C	-	72-pin QFN
LAN8820	Gigabit	1	RGMII	-	-	-	-40°C to +85°C	-	56-pin QFN
KSZ9031	Gigabit	1	MII/RMII/RGMII	-	✓	-	-40°C to +105°C	✓	48-/64-pin QFN
KSZ9131	Gigabit	1	MII/RMII/RGMII	-	✓	✓	-40°C to +105°C	✓	48-/64-pin QFN
VSC8531	Gigabit	1	RMII/RGMII	-	✓	✓	-40°C to +125°C	-	48 pin QFN
VSC8541	Gigabit	1	GMII/MII//RMII/ RGMII	-	✓	✓	-40°C to +125°C	-	68 pin QFN
VSC8584	Gigabit	4 Cu/4 Fbr	QSGMII/SGMII	✓	✓	✓	-40°C to +125°C	-	256 pin QFN
VSC8258	10G Optical	4Cu	XFI, SFI, KR	✓	✓	✓	-40°C to +125°C	-	256 pin QFN
VSC8490	10G Optical	2Cu	XAU1, RXAU1, XFI, SFI	✓	✓	✓	-40°C to +125°C	-	196 pin QFN

Notes: VSC devices maximum temperature is specified as junction temperature



SMART | CONNECTED | SECURE

Microchip Technology Inc. | 2355 W. Chandler Blvd. | Chandler AZ, 85224-6199 | microchip.com

The Microchip name and logo, the Microchip logo, LANCheck, LinkMD, MPLAB, PIC and Quiet-WIRE are registered trademarks and NetDetach, PICtail and SQI are trademarks of Microchip Technology Incorporated in the U.S.A. and other countries. Arm and Cortex are registered trademarks of Arm Limited (or its subsidiaries) in the EU and other countries. All other trademarks mentioned herein are property of their respective companies.
© 2021, Microchip Technology Incorporated. All Rights Reserved. 12/21

DS00002285D

