

NON-ISOLATED DC/DC CONVERTERS

5.5 Vdc - 13.2 Vdc Input

0.6 Vdc - 5.5 Vdc / 6 A Output



May. 12, 2016

Bel Power Inc., a subsidiary of Bel Fuse Inc.

SRPE-06E1A0

RoHS Compliant

Rev.J

Features

- Non-Isolated
- High Efficiency
- Fixed Frequency
- Low Cost
- Wide Input
- Class 2, Category 2, Non-Isolated DC/DC Converter (refer to IPC-9592B)
- Under-Voltage Lockout
- Wide Trim
- OCP/SCP
- Remote On/Off

Applications

- Networking
- Computers and peripherals
- Telecommunications



Description

The Bel SRPE-06E1A0 is part of the non-isolated dc/dc converter Power Module series. The modules use a SIP package. These converters are available in a range of output voltages from 0.6 Vdc to 5.5 Vdc over a wide range of input voltage ($V_{IN} = 5.5 \text{ Vdc} - 13.2 \text{ Vdc}$). The efficiency is typically 91% at 3.3 Vout ($V_{in}=12 \text{ Vdc}$) at full load.

Part Selection

Output Voltage	Input Voltage	Max. Output Current	Max. Output Power	Typical Efficiency	Model Number
0.6 V - 5.5 V	5.5 V - 13.2 V	6 A	33 W	91%	SRPE-06E1A0

Notes: 1. Add "G" suffix at the end of the model numbers listed above to indicate "Tray Packaging".

Ordering Part Number

S R PE - 06 E 1A 0 X
1 2 3 4 5 6 7 8

1---Mounting type,
2---RoHS Status,
3---Series name,
4---Output power,
5---Input range,
6---Output voltage,
7---Active logic and HSK feature,
8---Package type,

S –Surface mount
R – RoHS 6
PE –SMD Series name
06 – 33W output
E – 5.5-13.2V input
1A – 0.6-5.5V output
0 – active high, without HSK
G – Tray packaging

NON-ISOLATED DC/DC CONVERTERS

5.5 Vdc - 13.2 Vdc Input

0.6 Vdc - 5.5 Vdc / 6 A Output



May. 12, 2016

Bel Power Inc., a subsidiary of Bel Fuse Inc.

Absolute Maximum Ratings

Parameter	Min	Typ	Max	Unit	Notes
Input Supply Voltage	-0.3	-	15	V	All specification are typical at 25°C unless otherwise stated.
Remote On/Off	-0.3	-	15	V	
Ambient Temperature	0	-	50	°C	
Storage Temperature	-55	-	125	°C	
Altitude	-	-	2000	m	

Note: All specifications are typical at 25 °C unless otherwise stated.

Input Specifications

Parameter	Min	Typ	Max	Unit	Notes
Input Voltage	5.5	-	13.2	V	
Input Current (full load)	-	-	4.9	A	This power module is not internally fused. An input line fuse must always be used
Input Current (no load)	-	50	150	mA	
Remote Off Input Current	-	1	5	mA	
Input Reflected Ripple Current (rms)	-	7	20	mA	With simulated source impedance of 1000nH, 5Hz to 20MHz. Use a 1000uF/25V AL-Cap with ESR=0.03 ohm max and 2*100uF/25V Tan cap with ESR=0.013 ohm max, at 100KHz@25°C.
Input Reflected Ripple Current (Pk-Pk)	-	22	40	mA	
I ² t Inrush Current Transient	-	-	1	A ² s	
Turn-on Voltage Threshold	4.15	4.2	4.45	V	
Turn-off Voltage Threshold	3.7	4	4.2	V	

Note: All specifications are typical at 25 °C unless otherwise stated.

Output Specifications

Parameter	Min	Typ	Max	Unit	Notes	
Output Voltage Set Point	Vo, set ≥ 0.9Vdc	-2	-	2	%Vo,set	Setpoint test condition: Vin=12V, Iout=half load, Ta=25°C
	Vo, set < 0.9Vdc	-3	-	3	%Vo,set	
Load regulation	Vo ≥ 3.3 Vdc	-2	-	2	%Vo,set	Vin=12V, Io=0-6A, Ta=25°C .
	Vo < 3.3Vdc	-40	-	40	mV	
Line Regulation	Vo ≥ 3.3 Vdc	-1.5	-	1.5	%Vo,set	Vin=8-13.2V, Io=3A, Ta=25°C . Vin=5.5-13.2V, Io=3A, Ta=25°C .
	Vo < 3.3Vdc	-15	-	15	mV	
Regulation Over Temperature	-	0.8	-	%Vo,set		
Output Ripple and Noise (pk-pk)	-	60	200	mV	0-20MHz BW, with 360µF ceramic capacitor at output.	
Output Ripple and Noise (rms)	-	15	80	mV		
Output Current Range	0	-	6	A		
Output DC Current Limit	7	-	10	A		
Output Short-Circuit Current (Vo ≤ 20mV)(Hiccup Mode)	-	-	4	Adc		
Rise time	-	2	2.5	ms		
Turn On Time	-	2.9	5	ms		
Overshoot at Turn on	-	0	4.5	%		
Output Capacitance	200	-	2000	uF		
Transient Response						
ΔV50%~100% of Max Load	Overshoot	-	40	80	mV	di/dt=0.25A/us, Vin=12Vdc, Ta=25°C, with 360µF ceramic capacitor at output.
	Settling Time	-	80	200	us	
ΔV100%~50% of Max Load	Overshoot	-	40	80	mV	
	Settling Time	-	80	200	us	

Note: All specifications are typical at 25 °C unless otherwise stated.

NON-ISOLATED DC/DC CONVERTERS

5.5 Vdc - 13.2 Vdc Input

0.6 Vdc - 5.5 Vdc / 6 A Output



May. 12, 2016

Bel Power Inc., a subsidiary of Bel Fuse Inc.

General Specifications

Parameter	Min	Typ	Max	Unit	Notes
Efficiency 5.5V 3.3V 0.6V	92.2 90 69	94.2 91.6 71		%	The efficiency is measured at Vin=12V, full load and Ta=25°C.
Switching Frequency	-	650	-	kHz	
Output Voltage Trim Range(Wide Trim)	0.6	-	5.5	V	This voltage is achieved by trimming up output slowly.
Weight	-	2.5	-	g	
FIT		17		-	Calculated Telcordia SR-332, Issue 2 (Vin=12 V, Vo=5.5V, Io=6A, Ta = 40C, no forced air, 90% confidence Level FIT=10 ⁹ /MTBF)
Dimensions Inches (L × W × H) Millimeters (L × W × H)	0.41 x 0.65 x 0.339 10.41 x 16.51 x 8.60			-	

Note: All specifications are typical at 25 °C unless otherwise stated.

Efficiency Data

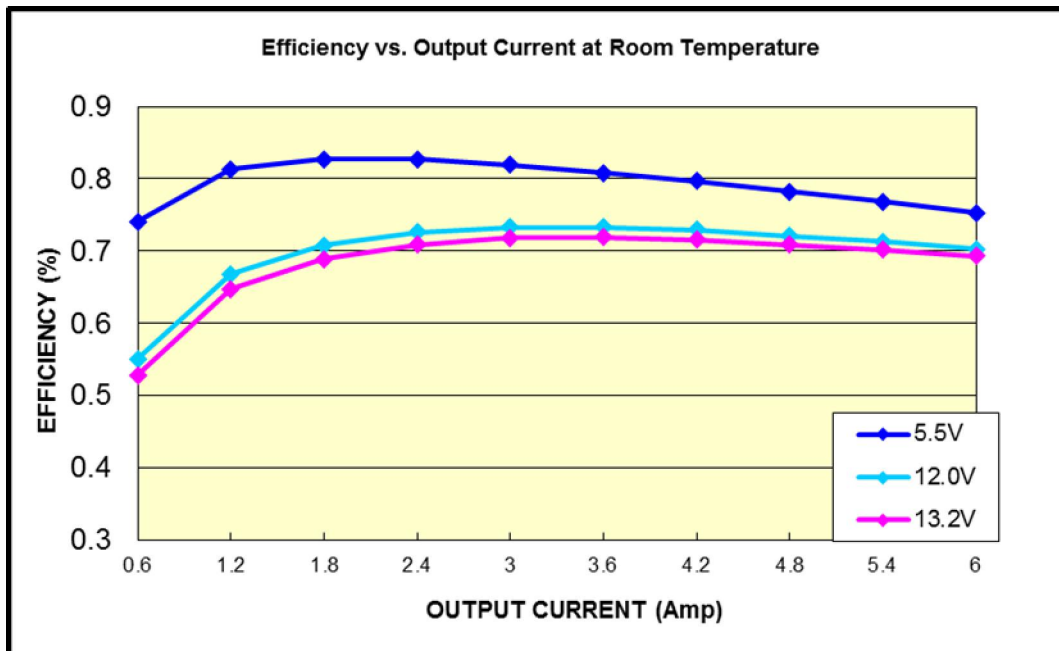

Vout: 0.6V

NON-ISOLATED DC/DC CONVERTERS

5.5 Vdc - 13.2 Vdc Input

0.6 Vdc - 5.5 Vdc / 6 A Output



May. 12, 2016

Bel Power Inc., a subsidiary of Bel Fuse Inc.

Efficiency Data (continued)

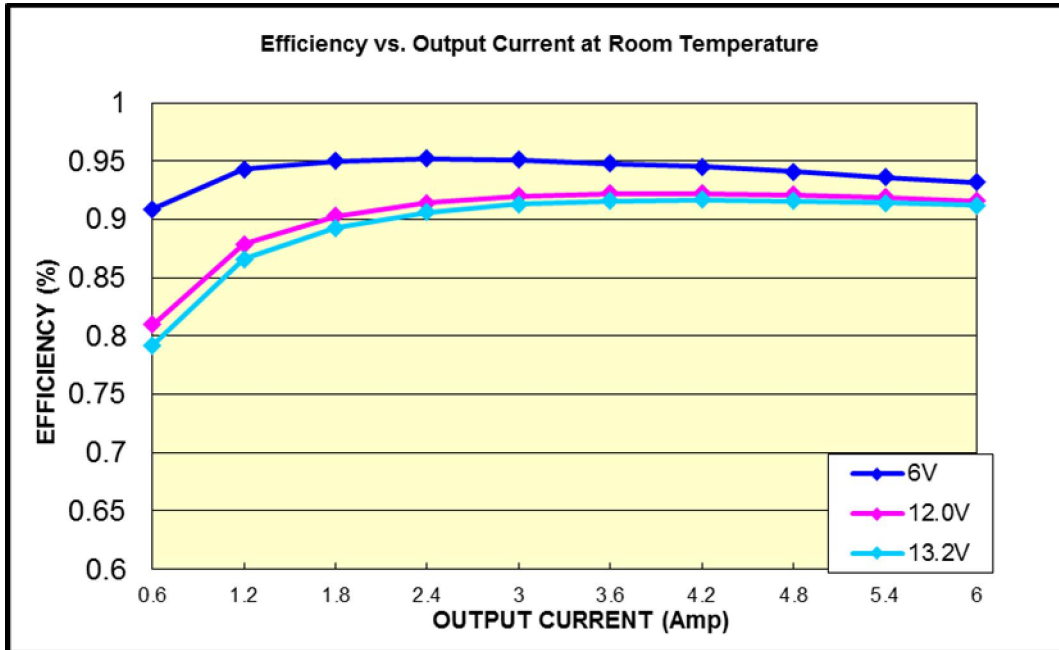

Vout: 3.3V

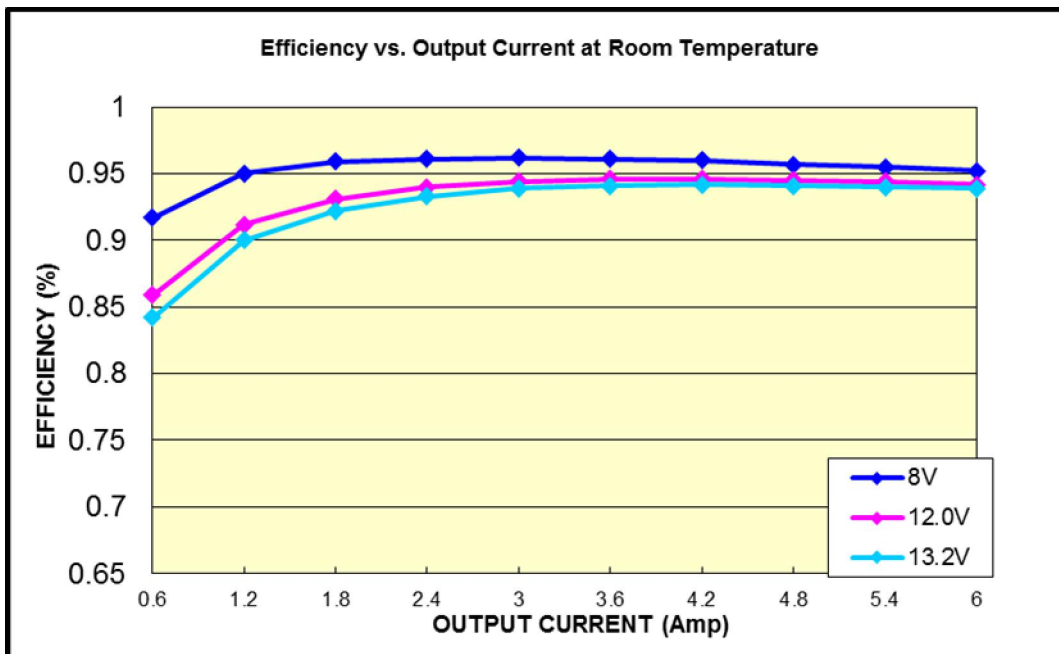

Vout: 5.5V

NON-ISOLATED DC/DC CONVERTERS

5.5 Vdc - 13.2 Vdc Input

0.6 Vdc - 5.5 Vdc / 6 A Output



May. 12, 2016

Bel Power Inc., a subsidiary of Bel Fuse Inc.

Input under-voltage lockout

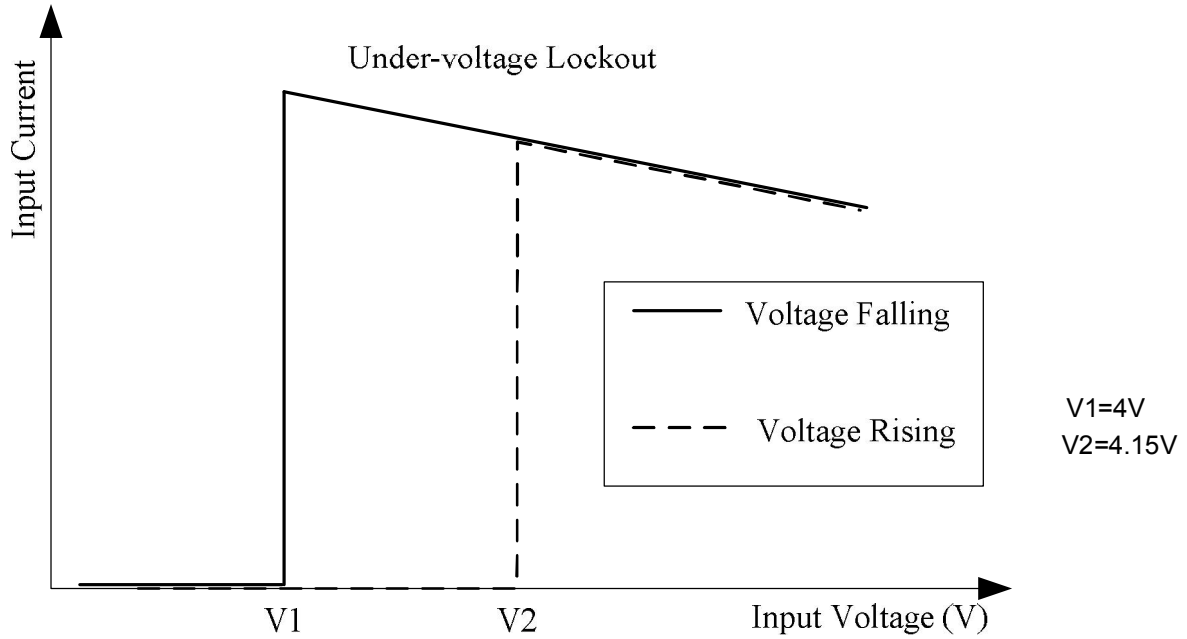

Thermal Derating Curves

$V_{in}=12V$, with maximum junction temperature of semiconductors derated to 115C

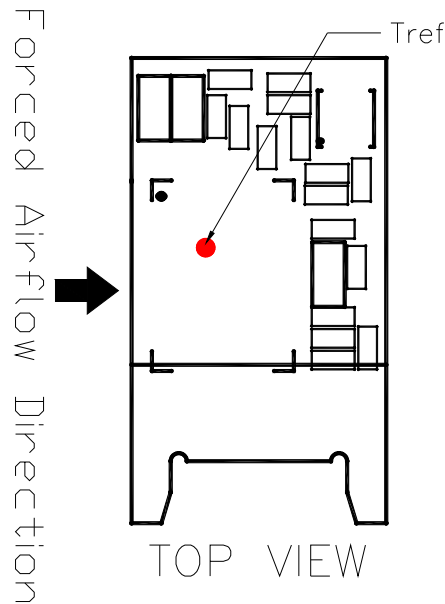

NON-ISOLATED DC/DC CONVERTERS

5.5 Vdc - 13.2 Vdc Input

0.6 Vdc - 5.5 Vdc / 6 A Output



May. 12, 2016

Bel Power Inc., a subsidiary of Bel Fuse Inc.

Thermal Derating Curves(continued)

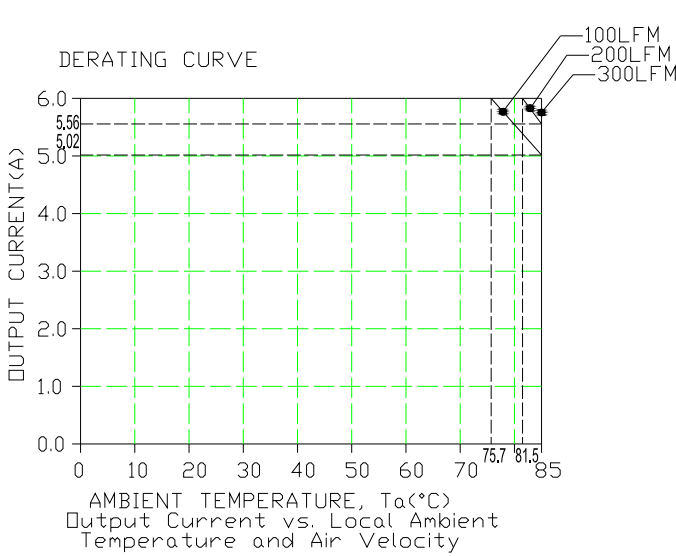

Vout=0.6V

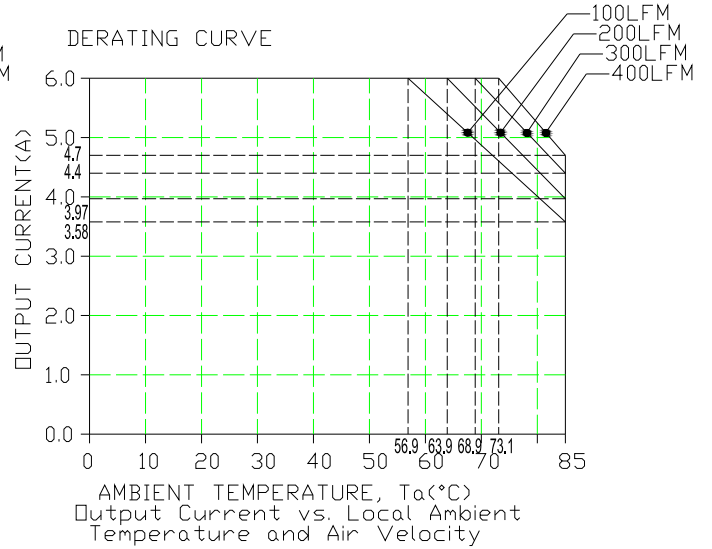

Vout=1.8V

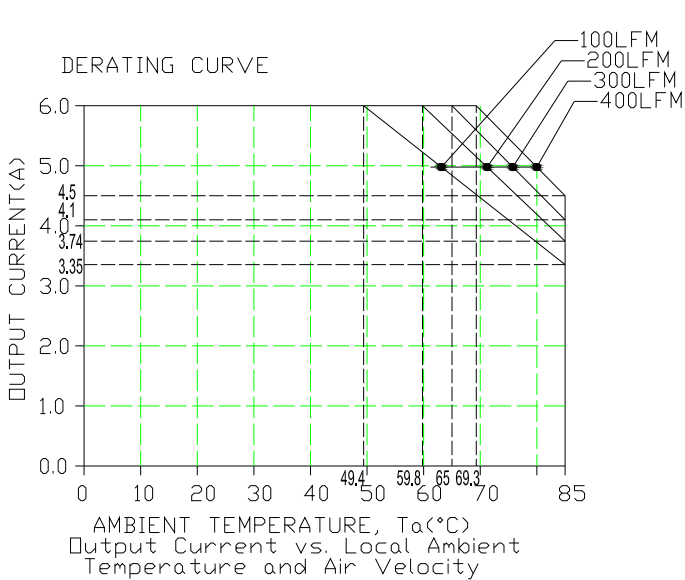

Vout=3.3V

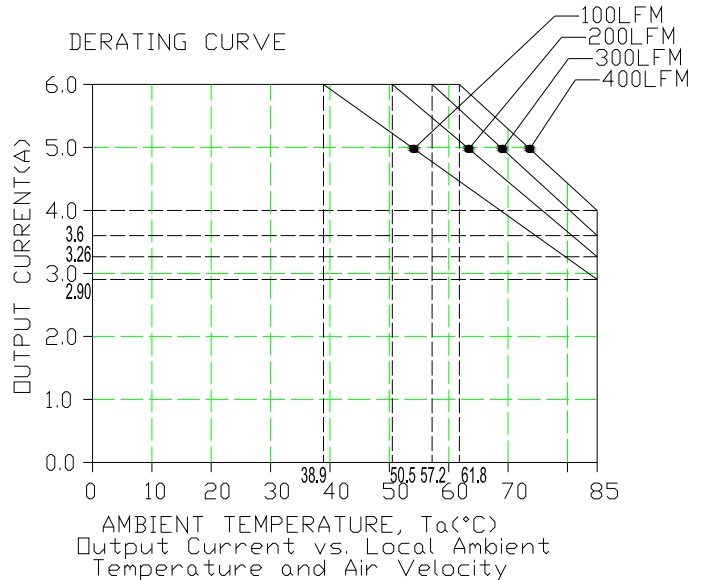

Vout=5.5V

NON-ISOLATED DC/DC CONVERTERS

5.5 Vdc - 13.2 Vdc Input

0.6 Vdc - 5.5 Vdc / 6 A Output



May. 12, 2016

Bel Power Inc., a subsidiary of Bel Fuse Inc.

Ripple and Noise Waveform

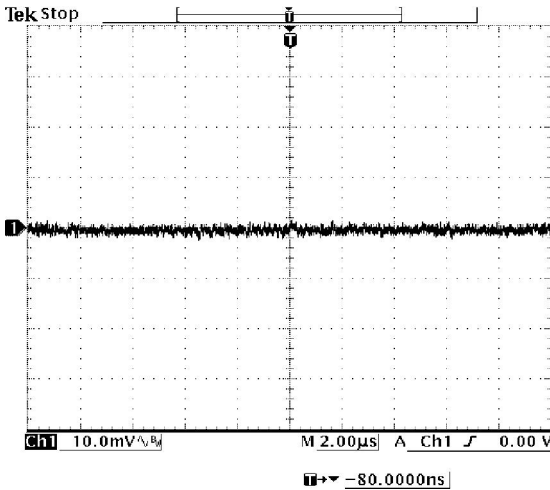

Ripple and noise at full load, 12V input,
0.6V output and Ta=25 degC

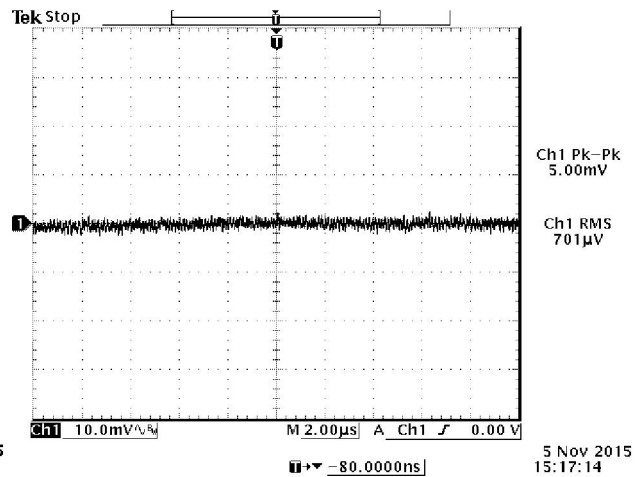

Ripple and noise at full load, 12V input,
3.3V output and Ta=25 degC

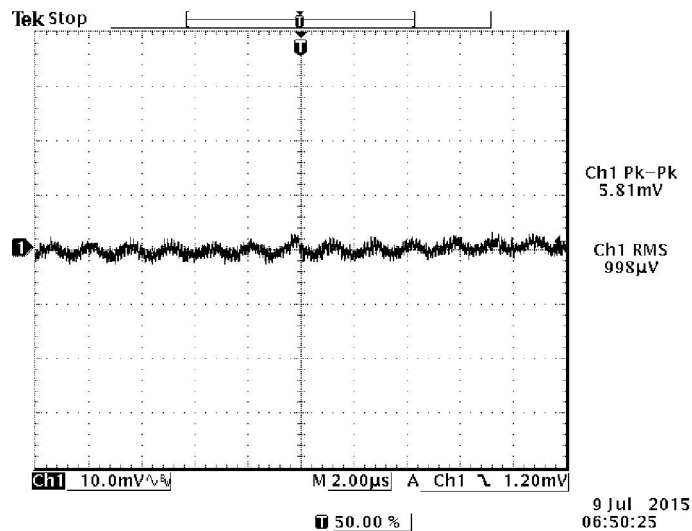

Ripple and noise at full load, 12V input, 5.5V output and Ta=25 degC

Note: Test condition of the output ripple and noise: 0-20MHz BW, with 360uF ceramic cap at output

NON-ISOLATED DC/DC CONVERTERS

5.5 Vdc - 13.2 Vdc Input

0.6 Vdc - 5.5 Vdc / 6 A Output



May. 12, 2016

Bel Power Inc., a subsidiary of Bel Fuse Inc.

Transient Response Waveforms

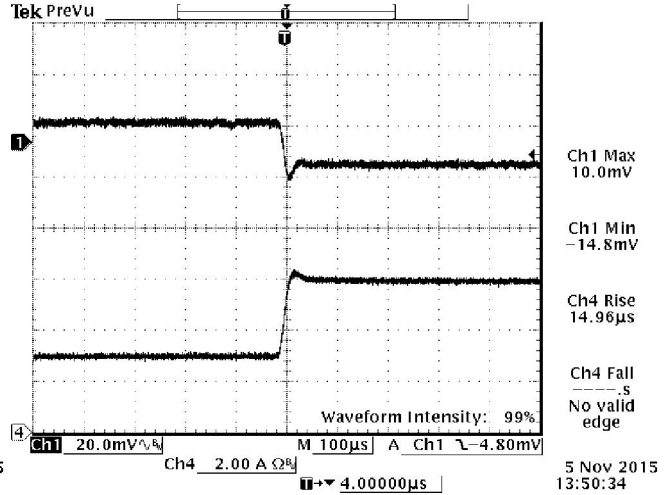
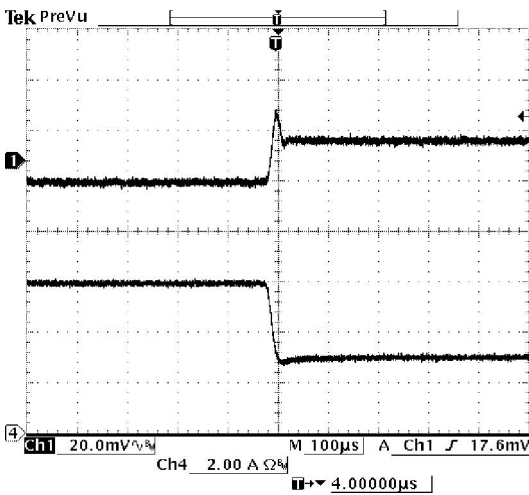

100%-50% Load Transients at Vin=12V, Vout=0.6V@Ta=25°C

50%-100% Load Transients at Vin=12V, Vout=0.6V@Ta=25°C

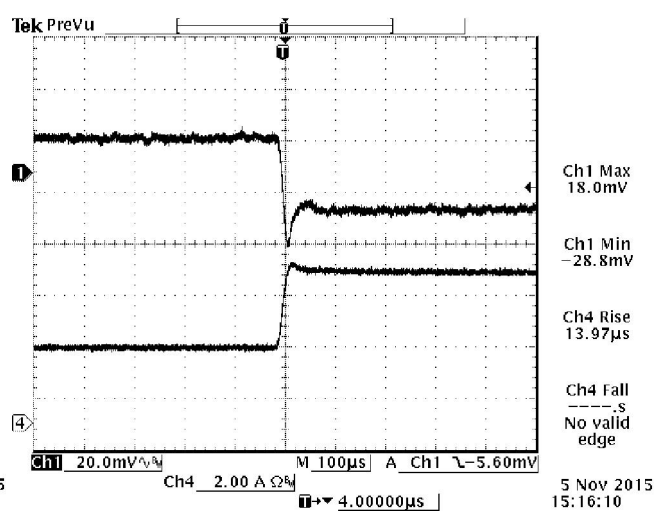
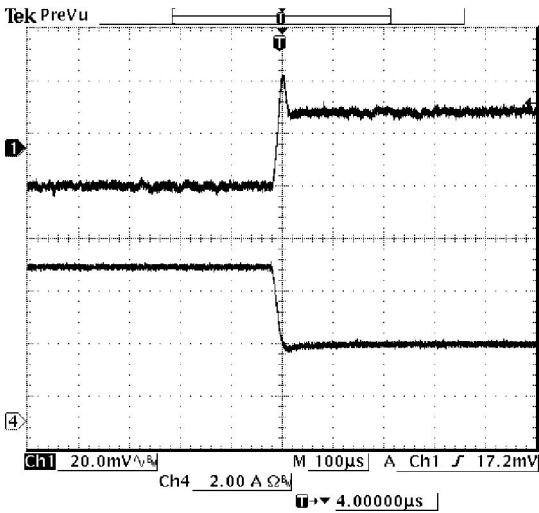

100%-50% Load Transients at Vin=12V, Vout=3.3V@Ta=25°C

50%-100% Load Transients at Vin=12V, Vout=3.3V@Ta=25°C

NON-ISOLATED DC/DC CONVERTERS

5.5 Vdc - 13.2 Vdc Input

0.6 Vdc - 5.5 Vdc / 6 A Output



May. 12, 2016

Bel Power Inc., a subsidiary of Bel Fuse Inc.

Transient Response Waveforms (continued)

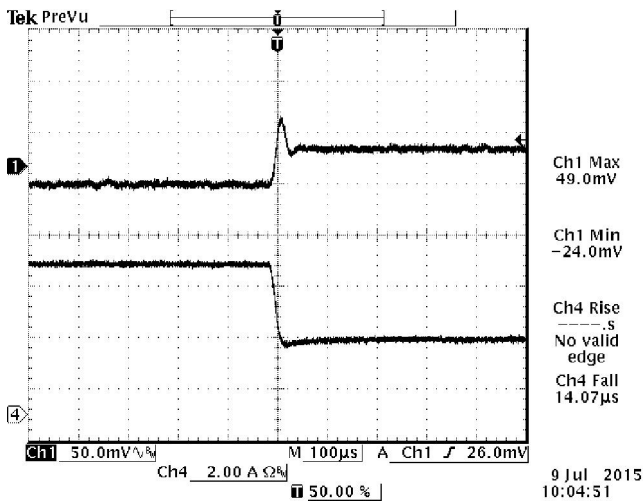

100%-50% Load Transients at Vin=12V,
Vout=5.5V@Ta=25°C

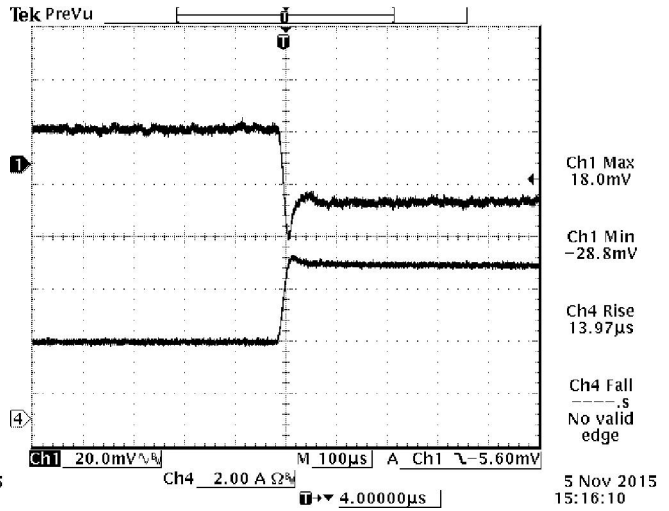

50%-100% Load Transients at Vin=12V,
Vout=5.5V@Ta=25°C

Note: Test condition of the transient response: di/dt=0.25A/uS, with 360uF ceramic cap at output

Remote On/Off

Parameter		Min	Typ	Max	Notes
Signal Low (Unit Off)	Active High	-0.3 V	-	0.8V	Remote On/Off pin is open, the module is off.
Signal High (Unit On)		2.4 V	-	18 V	

Recommended remote on/off circuit for active high

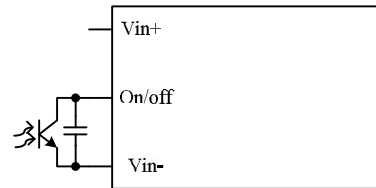
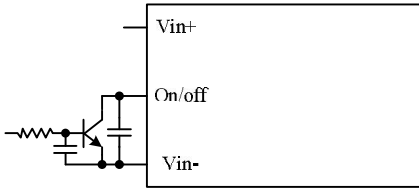

Control with open collector/drain circuit

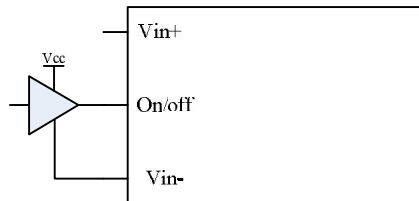

Control with photocoupler circuit

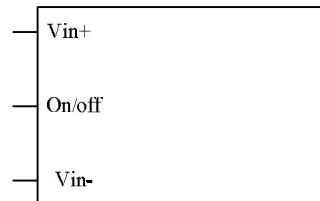

Control with logic circuit

Permanently off

NON-ISOLATED DC/DC CONVERTERS

5.5 Vdc - 13.2 Vdc Input

0.6 Vdc - 5.5 Vdc / 6 A Output



May. 12, 2016

Bel Power Inc., a subsidiary of Bel Fuse Inc.

Trim

Trim up circuit (using an external resistor)

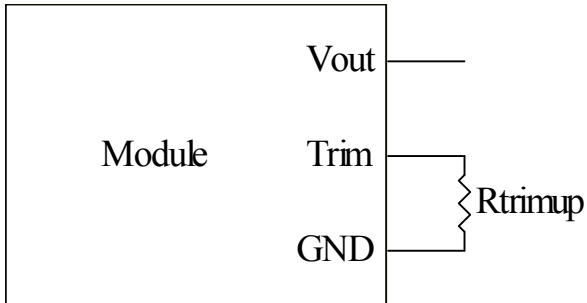

$$R_{trim} = \frac{1.2}{V_o - 0.6} k\Omega$$

V_o is the desired output voltage

R_{trim} is the required resistance between TRIM and GND

SRPE-06E1A0 Trim up Resistor Calculate

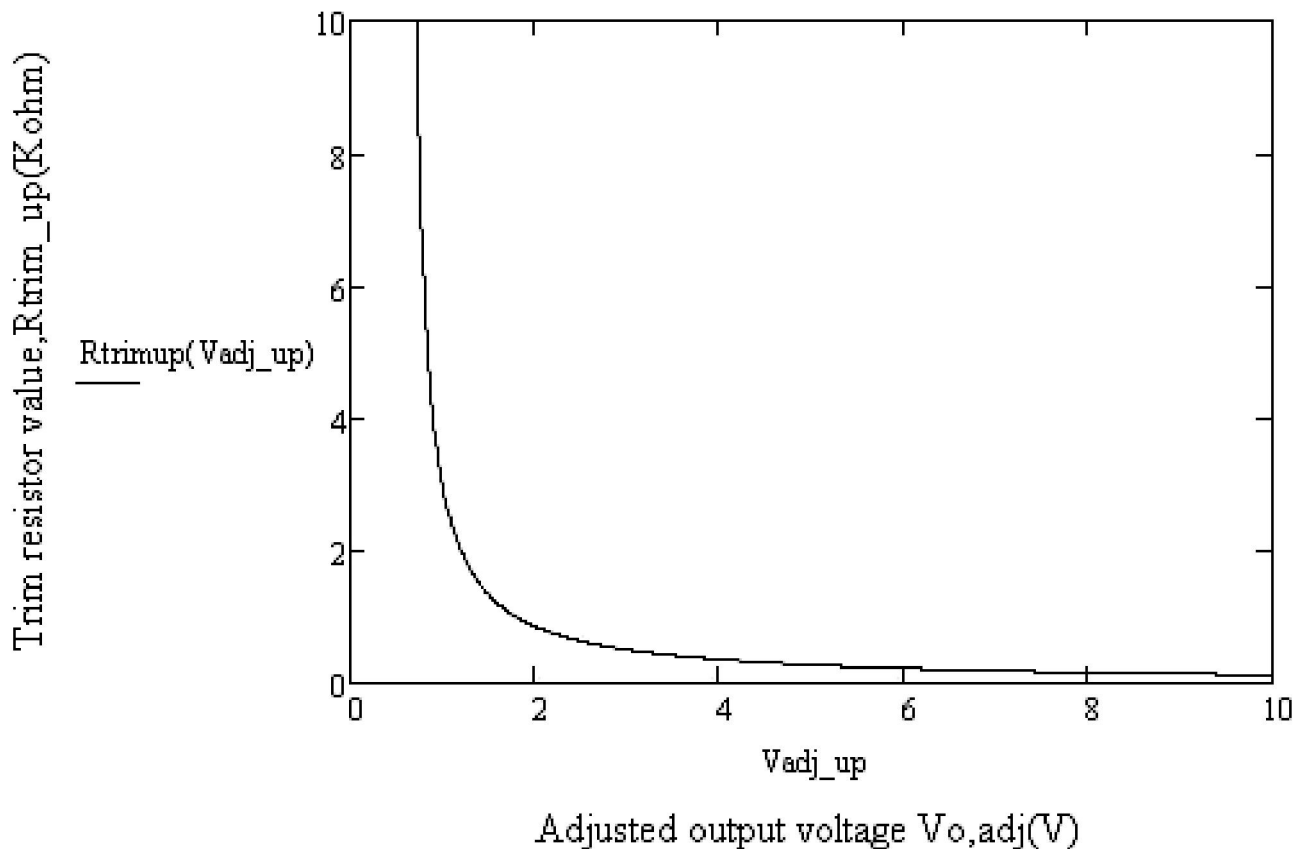

NON-ISOLATED DC/DC CONVERTERS

5.5 Vdc - 13.2 Vdc Input

0.6 Vdc - 5.5 Vdc / 6 A Output



May. 12, 2016

Bel Power Inc., a subsidiary of Bel Fuse Inc.

Soldering Information

The SRPE-06E1A0G modules are designed to be compatible with a Paste-In-Hole assembly process. The suggested Pb-free solder paste is Sn/Ag/Cu(SAC). The recommended reflow profile using Sn/Ag/Cu solder is shown in the following. Recommended reflow peak temperature is 245°C while the part can withstand peak temperature of 260°C maximum for 10seconds. This profile should be used only as a guideline. Many other factors influence the success of SMT reflow soldering. Since your production environment may differ, please thoroughly review these guidelines with your process engineers.

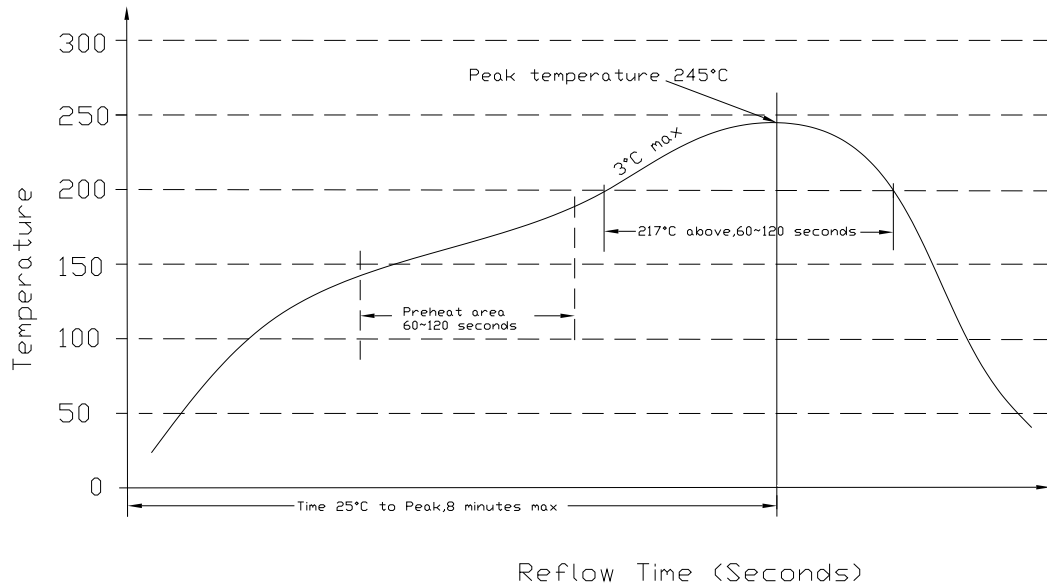

MSL Rating

The SRPE-06E1A0G modules have a MSL rating of 3.

Storage and Handling

The SRPE-06E1A0G modules are designed to be compatible with J-STD-033 Rev:A (Handling, Packing, Shipping and Use of Moisture /Reflow Sensitive surface Mount devices). Moisture barrier bags (MBB) with desiccant are applied. The recommended storage environment and handling procedure is detailed in J-STD-033.

Pre-baking

This component has been designed, handled, and packaged ready for pb-free reflow soldering. If the assembly shop follows J-STD-033 guidelines, no pre-bake of this component is required before being reflowed to a PCB. However, if the J-STD-033 guidelines are not followed by the assembler, Bel recommends that the modules should be pre-baked @ 120~125°C for a minimum of 4 hours (preferably 24 hours) before reflow soldering.

NON-ISOLATED DC/DC CONVERTERS

5.5 Vdc - 13.2 Vdc Input

0.6 Vdc - 5.5 Vdc / 6 A Output



May. 12, 2016

Bel Power Inc., a subsidiary of Bel Fuse Inc.

Mechanical Outline

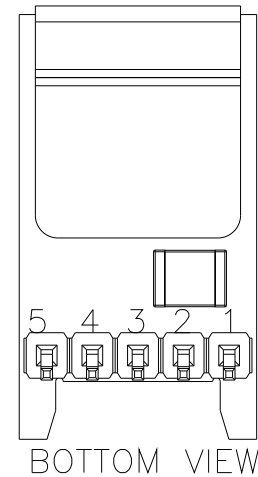
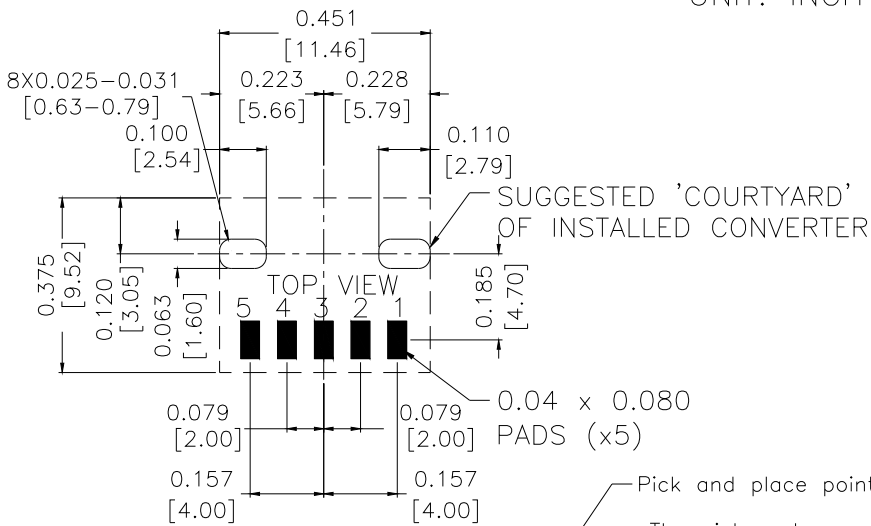
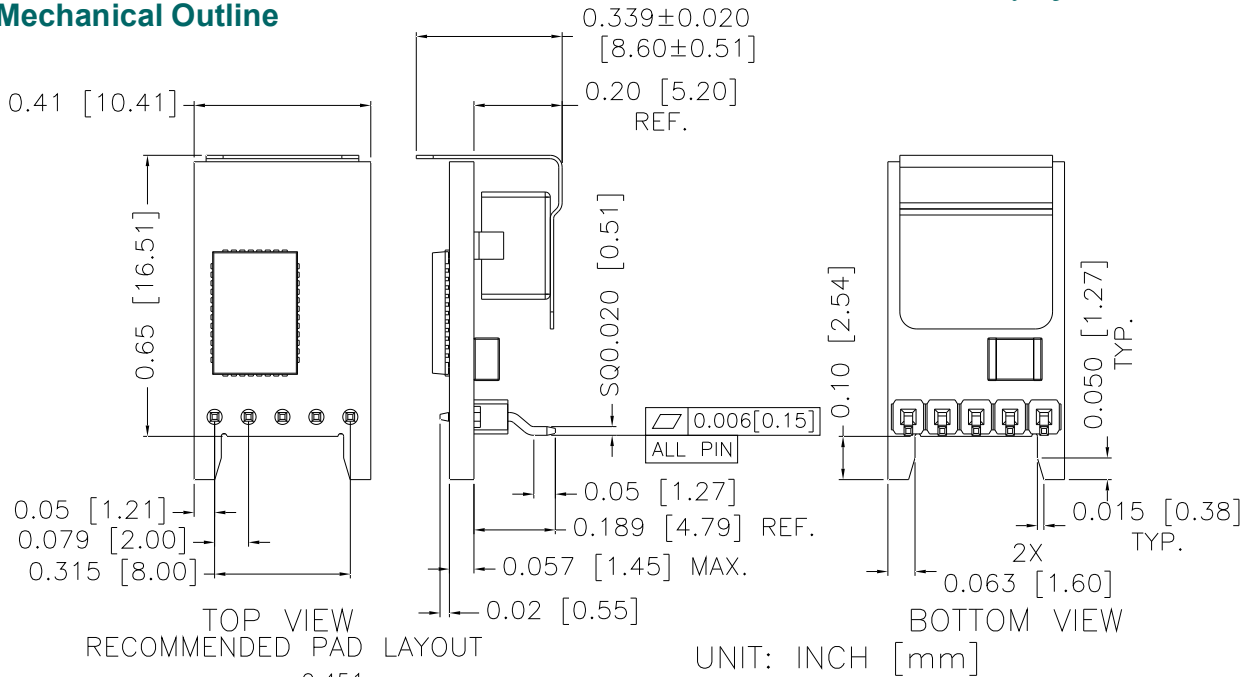

Pin Connections

Pin	Function
1	Enable
2	Vin
3	GND
4	Vout
5	Trim

Note:

- 1) All Pins: Material - Copper Alloy; Finish - 3 micro inches minimum Gold over 50 micro inches minimum Nickel plate.
- 2) Undimensioned components are shown for visual reference only.
- 3) All dimensions in inches (mm); Tolerances: x.xx +/-0.02 in[0.5mm] x.xxx +/-0.010 in[0.25mm].

NON-ISOLATED DC/DC CONVERTERS

5.5 Vdc - 13.2 Vdc Input

0.6 Vdc - 5.5 Vdc / 6 A Output



May. 12, 2016

Bel Power Inc., a subsidiary of Bel Fuse

Datasheet Revision History

Date	Revision	Changes Detail	Approval
2013-8-20	A	First Release	XF JIANG
2014-1-23	B	1.Mechanical drawing; 2. Output ripple and noise; 3.Output DC Current Limit; 4.Transient Response; 5.add ROHS logo; 6.Output Voltage Set Point; 7.Load Regulation; 8.Line Regulation; 9.Output DC Current Limit; 10.Efficiency; 11.Turn on/off Voltage Threshold; 11.Update on/off discription, add a note for UVLO.	XF JIANG
2014-4-8	C	Update MD.	XF JIANG
2014-6-24	D	Update MD.	XF JIANG
2014-7-3	E	Update part number explanation, RoHS compliance, Add MD Note.	XF JIANG
2014-11-5	F	Update MD.	XF JIANG
2014-11-18	G	Update General Specifications, TD, MD.	XF JIANG
2015-11-12	H	Update Input Specs, Output Specs, General, Efficiency Data, NR, TR, MD.	XF JIANG
2015-12-22	I	Update Output Specs.	XF JIANG
2016-05-12	J	Update Thermal Derating Curves.	XF JIANG

RoHS Compliance

Complies with the European Directive 2011/65/EU, calling for the elimination of lead and other hazardous substances from electronic products.



©2016 Bel Fuse Inc. Specifications subject to change without notice.051216

CORPORATE

Bel Fuse Inc.
206 Van Vorst Street
Jersey City, NJ 07302
Tel 201-432-0463
Fax 201-432-9542
www.belfuse.com

FAR EAST

Bel Fuse Ltd.
8F/ 8 Luk Hop Street
San Po Kong
Kowloon, Hong Kong
Tel 852-2328-5515
Fax 852-2352-3706
www.belfuse.com

EUROPE

Bel Fuse Europe Ltd.
Preston Technology Management Centre
Marsh Lane, Suite G7, Preston
Lancashire, PR1 8UD, U.K.
Tel 44-1772-556601
Fax 44-1772-888366
www.belfuse.com