

## GLOSSARY AND DEVELOPMENT TOOLS

**Accuracy** – the maximum deviation from the specified overvoltage and overcurrent protection levels.

**Auto-retry** – an auto-retrying device will turn itself back on after a thermal shutdown once the die temperature is below the hysteresis value.

**Bias current** – the current needed by the eFuse itself to maintain operation.

**Overload current limit, or current limit trip-point** – the eFuse reacts to overcurrent events by reducing the conductivity of the pass element once the current exceeds this limit.

**Short-circuit current** – when a strong overload occurs and the output voltage drops as a consequence, the device limits the current to a level below the regular current limit.

**dV/dt** – this refers to the internal circuitry that controls the output voltage rise at turn-on. The external dV/dt pin allows the user to adjust the soft-start time.

**Enable-fault** – the enable-fault pin is a dual-function pin: it lets the user enable and disable the device and at the same time provides the device status through a three-state logic.

**Gate driver** – to protect the supply and pass element, STEF01 and STEF12S include an internal charge pump to drive an external MOSFET that prevents reverse currents and large transient voltages that may occur during high-current limiting.

**Hysteresis** – to prevent an auto-retrying device from repeatedly turning ON and OFF after a thermal shutdown, the device only turns back on once the temperature has dropped by the hysteretic value.

**Latch** – when a thermal fault occurs, the device will remain OFF until the power or enable-signal is cycled by the user.

**Output voltage clamp** – if the input voltage exceeds the pre-defined voltage clamp value, the internal protection circuit ensures the output voltage does not rise above this preset value.

**Pass element** – the voltage and current pass through a low-resistive power MOSFET that can be controlled to limit the output current and voltage in reaction to fault conditions.

**Power dissipation** – during normal operation, the power dissipated by the device depends on the pass element's RDS(on) and the load current. When voltage/current is regulated, which happens during startup and in case of faults, the excess power is dissipated in the form of heat. In persistent faulty conditions, this heat causes the device to shut down as a consequence of thermal protection. Thermal design and correct soft-start configurations are important to prevent unwanted shutdowns, which are most likely to occur during startup phases or in high and continuous current conditions.

**Power Good (PG)** – a signal to indicate that the output voltage is very close to the input and that no current/voltage limitation is in place. It can be used for power-sequencing, reset-triggering, and more.

**Soft-start (SS)** – a soft-start is a controlled delivery of the output which minimizes inrush currents to protect the power supply from overloading. The soft-start time can be extended by adding a capacitor to the dV/dt pin.

**Thermal shutdown** – during a persistent fault, the eFuse die will heat up. Once the shutdown temperature is reached, the device will turn off the internal pass element and enter latch or auto-retry state.

**UVLO (undervoltage lockout)** – the UVLO ensures that the device does not turn on until the supply voltage is high enough.

## DEMOBOARDS

Part number	Product	Description
STEVAL-EFUSE01	STEF01	Evaluation board based on the STEF01 fully programmable universal electronic fuse
STEVAL-IFP021V1	STEF12/STEF05	5 V and 12 V power line protection based on STEF05 and STEF12 electronic fuses

For more information, visit us on <https://st.com/hot-swap>



Order code: BR2310EFUSEQR

At STMicroelectronics  
we create  
technology that  
starts with You

For more information on ST products and solutions, visit [www.st.com](http://www.st.com)

© STMicroelectronics - October 2023 - Printed in United Kingdom - All rights reserved  
ST and the ST logo are registered and/or unregistered trademarks of STMicroelectronics International NV or its affiliates in the EU and/or elsewhere. In particular, ST and the ST logo are Registered in the US Patent and Trademark Office.  
For additional information about ST trademarks, please refer to [www.st.com/trademarks](http://www.st.com/trademarks).  
All other product or service names are the property of their respective owners.



# eFuse (electronic fuse) Quick reference guide





## Ensuring safer designs and more efficient applications

### HOW DOES AN eFuse WORK

An **eFuse** is a low-resistance switch connected in series to the main power rail and controlled by logic circuitry to protect loads and power supplies. Smaller, faster, and more efficient than conventional fuses or polymeric PTCs, eFuses detect and react to overcurrent and overvoltage conditions, and do not require replacement after a fault event.

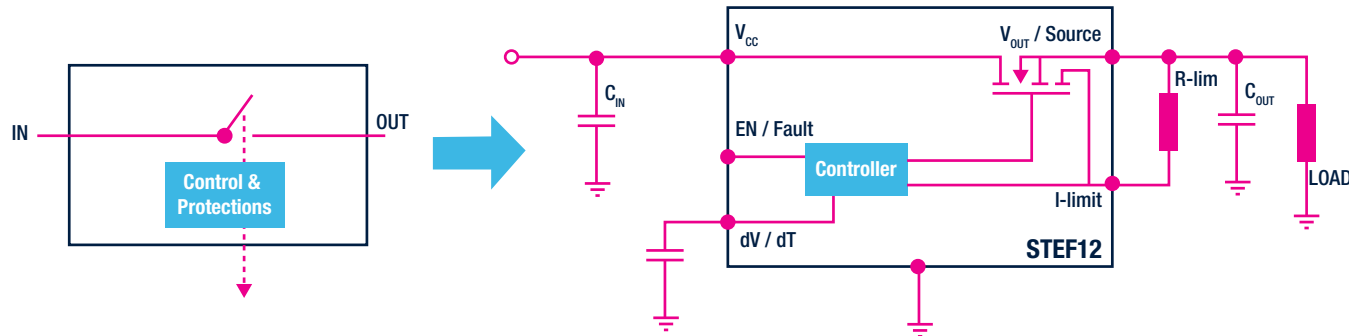

When an overload or short-circuit condition occurs, the eFuse limits the current to a pre-defined safe value. When an overvoltage condition occurs, the eFuse clamps the output voltage to a safe level, thus protecting the load from abnormalities caused by malfunctioning power supplies.

The eFuse disconnects the load from the power supply if fault conditions are persistent. Depending on the version, the device operates either in latch-off mode, which means it is switched-off and must be re-armed manually, or in auto-retry mode, where the device will attempt to automatically re-start.

ST eFuses are available in **single-channel** or **dual-channel** configuration.

They are housed in a variety of small plastic packages, such as TSOT, DFN, QFN, TSSOP, and Flip Chip.

## KEY BENEFITS OF ELECTRONIC FUSES

### Quick and intelligent response to faults

Unlike conventional fuses, which are based on the principle that a conductor will overheat and melt during an overload condition, the eFuse only clamps the output voltage and/or limits the throughput current, thus allowing the device to be supplied correctly, before eventually disconnecting the load in case of persistent failure. This prevents load and supply damage from occurring and avoids false triggering caused by transient conditions. Moreover, in applications powered by DC buses, eFuses reduce the bus droop due to faulty loads, avoiding the propagation of nuisance or undervoltage to other loads connected to the same bus.

### Reduced maintenance

Since eFuses do not sacrifice their pass element, they can immediately be reset with a signal from the system by either cycling the supply power or by simply waiting if auto-retry is used. The equipment's uptime is maximized and the cost and complexity of maintenance are reduced.

### Hot-plug/hot-swap capability

Inrush current conditions can occur during startup or hot-plugging. eFuses ramp the output voltage up in a controlled manner to prevent large inrush currents from overloading the power supply. This feature is crucial when multiple loads are supplied by a single power supply.

### Flexible application design

Every eFuse can be programmed and tailored to your specific needs. Most eFuses allow users to set the current limit and startup time. The undervoltage lockout and output clamp levels, as well as the device's operating mode (latch-off or auto-retry mode), can also be configured on certain part numbers.

## KEY FEATURES

### Output voltage clamping

Each eFuse has a predefined maximum output voltage safe value. If the input voltage exceeds this value, the eFuse clamps the output voltage to the preset value and allows the device to operate without damaging the load or system. If the overvoltage is persistent, the eFuse disconnects the load. Most eFuses have a pre-set voltage clamp value. The **STEF01** allows users to configure it.



### Current limiting

When an overload condition occurs, the eFuse reduces the conductivity of the internal pass element to effectively limit the current to a preconfigured value. If a strong overload or short circuit occurs, the device enters the foldback current limit, and eventually disconnects the load, thus protecting the power supply. This value is usually configured using an external resistor.



### Undervoltage lockout

The undervoltage lockout feature disconnects the load from the supply if the input voltage is lower than a preset minimum. By avoiding issues caused by insufficient supply voltage such as wrong voltages from bandgap references, incorrect control signals in logical circuitry, and transistors being only partially ON or OFF, the undervoltage lockout increases system predictability. The **STEF01** allows users to set the undervoltage lockout threshold between 8 and 45 V.



### Turn-on delay/soft-start

The eFuse provides a defined and predictable ramp-up of the output voltage during startup, to ensure the inrush current is maintained within safe confines and protects both the load and the power supply. The soft-start duration can be easily configured by an external capacitor.



### Enable/Fault pin

All eFuses feature an enable/disable pin, to turn-on/off the device. In addition, some products offer the enable/fault pin, which is a dual-function pin that allows users to manually turn the output off and to read the current state of the device. The eFuse can be reset by toggling this pin after a thermal shutdown. The pin can be used as a regular enabling pin and can be connected to a monitoring circuit to notify thermal shutdown events. It can also be connected to the Enable/Fault pins of other eFuses, to achieve simultaneous Enable/Disable operation for all devices.



### International safety standards

The eFuses are integrated with current limiters providing a complete set of protections for final applications. Using an eFuse can help ease the certification of the systems to international safety standards requiring a current or power limitation function. Additionally, some eFuses are certified for compliance to international standards at the product level, such as UL 2367 and IEC 62368-1, which assess the robustness of the overcurrent protection:

- STEF12 is UL 2367 certified
- STEF01 is UL 2367 and IEC 62368-1 certified
- STEF12S family of eFuses is UL 2367 and IEC 62368-1 certified
- STELDP01 is UL 2367 and IEC 62368-1 certified

## eFuses KEY PRODUCTS AND APPLICATIONS

Configuration	Applications	Voltage	Product	Specifications
Single eFuse	<ul style="list-style-type: none"> <li>• Server/datacenter</li> <li>• HDD/SSD</li> <li>• Network switch</li> <li>• Industrial controls/alarm</li> <li>• Home appliances</li> </ul>	12 V	<b>STEF12H60M</b>	12 V, 60 A high precision eFuse with 0.85 mΩ R <sub>DS(ON)</sub> current, and temperature monitor pins. Parallel configuration. QFN 32 5x5 package
		8-48 V	<b>STEF01</b>	8 – 48 V, 4 – 5 A Fully programmable eFuse with 30 mΩ R <sub>DS(ON)</sub> HTSSOP14 package
		12 V	<b>STEF12S</b>	12 V, 4 A high precision simple eFuse TSOT23-8L and DFN 3x3 packages
Dual eFuse	<ul style="list-style-type: none"> <li>• Data-storage</li> <li>• HDD</li> <li>• SSD</li> <li>• NAS/SAN</li> </ul>	5 V	<b>STEF05S</b>	5 V, 4 A high precision simple eFuse TSOT23-8L package
		5 V + 12 V	<b>STEF512GR</b>	5 V + 12 V in one 3 A eFuse TSOT23-8L package
			<b>STEF512PUR</b>	5 V + 12 V in one 3 A eFuse with current monitor QFN 2x3 package
			<b>STEF512SRDB</b> <b>STEF512SRX</b> <b>STEF512SRI</b>	5 V + 12 V in one 3 A eFuse with reverse current protection on 5 V channel DFN 2x3 package

## eFuses and hot-swap ICs

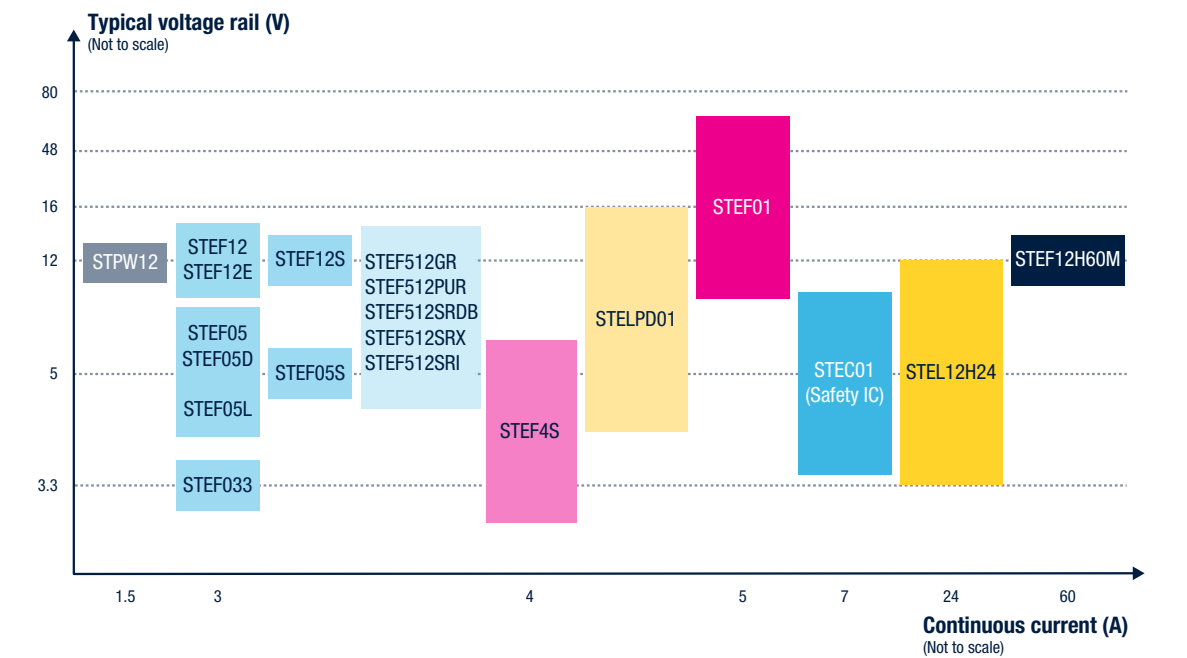

**Legend:** — Power Breaker — Standard eFuses — Dual channel 5 V + 12 V — Fully programmable — 3.3 V or 5 V rail — Ground path safety switch — High power eFuse — High power load switch — Load/power switch