



life.augmented

# ST's Condition Monitoring Solutions



# Introduction

Condition-based Monitoring (CbM) and Predictive Maintenance (PM) are two maintenance strategies which aim at optimizing equipment efficiency and reducing service timing and costs during equipment lifecycle.

**Condition Monitoring (CM)** is the monitoring of several parameters such as equipment vibration and temperature to **identify potential issues** such as misalignments or bearing failures. Condition monitoring tools can, for instance, map equipment degradation when a vibration analysis shows a change in the harmonic frequency of rotating equipment components. Frequency analyses can be based both on vibrometer and microphone data.

Also **MCSA** (Motor Current Signal Analysis ) is used as technique that is complementary with respect to Vibration Analysis. It offer benefits and works better on some specific anomalies like unbalance.

Continuous Condition Monitoring techniques can be applied on several pieces of equipment such as compressors, pumps, spindles and motors and can also be implemented to identify partial discharge on machine or vacuum leaks.

**Predictive Maintenance** is based on Condition Monitoring, anomaly detection and classification algorithms, and integrates predictive models which can **estimate the remaining machine runtime left, according to detected abnormalities**. This approach uses a wide range of tools, such as statistical analyses and Machine Learning to predict the state of the equipment.

## CONDITION BASED MONITORING TYPICAL APPLICATIONS

Factory Automation		 Industrial motor vibration monitoring	 Bearings ultrasound monitoring	 Motor current monitoring
Power, Energy & Utilities		 Pipe flow monitoring	 Temperature, humidity, gas monitoring	 Acoustic monitoring
Home Appliances and Building Automation		 Compressor vibration monitoring	 Washing machine, vacuum cleaner monitoring	 Lighting monitoring
Structural Health Monitoring		 Infrastructure inclination monitoring	 Railways monitoring	 Bridge vibration monitoring

## ST'S PORTFOLIO FOR CONDITION MONITORING AND PREDICTIVE MAINTENANCE IN INDUSTRY 4.0



Condition Monitoring and Predictive Maintenance are value-added yet challenging applications in Industry 4.0. ST has therefore deployed advanced ICs and an ecosystem of evaluation tools, software, documentation and online dashboards for remote monitoring, which are continuously updated to be in keeping with industrial needs.



## ARCHITECTURE AND MAIN ELEMENTS: SMART SENSOR NODES AND GATEWAY

From designing smart sensor nodes and configuring embedded software running in sensor nodes and the gateway, to developing software to be integrated in the Cloud or company Enterprise Resource Planning (ERP) system, Predictive Maintenance requires a variety of skills and competencies. **Machine Learning** and **Artificial Intelligence** algorithms can be implemented to ensure technical abnormalities are detected early and equipment uptime is maximized

Today market is mainly segmented in:

- New equipment (greenfield): Integration possible with power supply and existing sensors
- In-field maintenance (retrofit): Battery-powered simplifies installation

### Smart Sensor Node

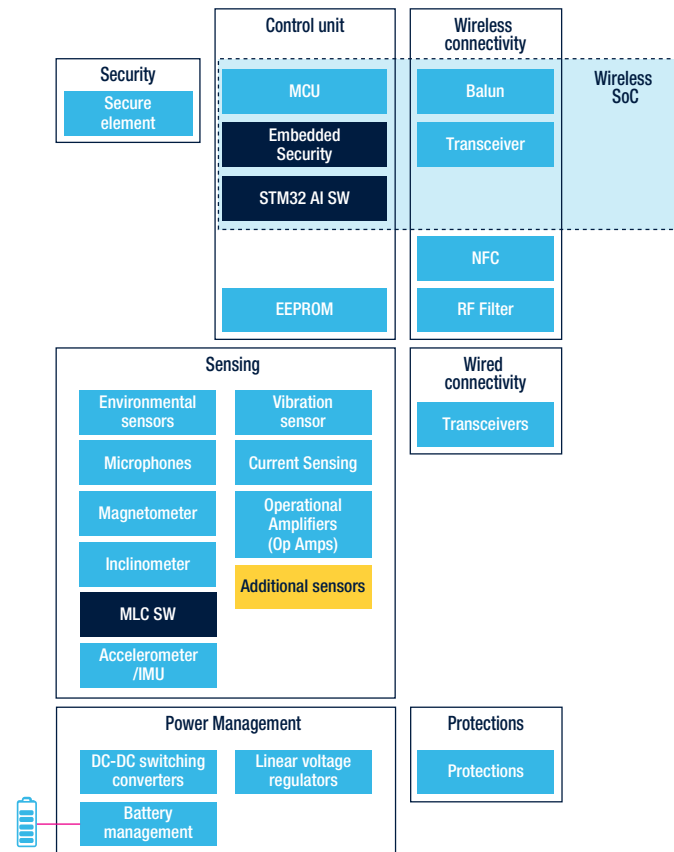

### Gateway

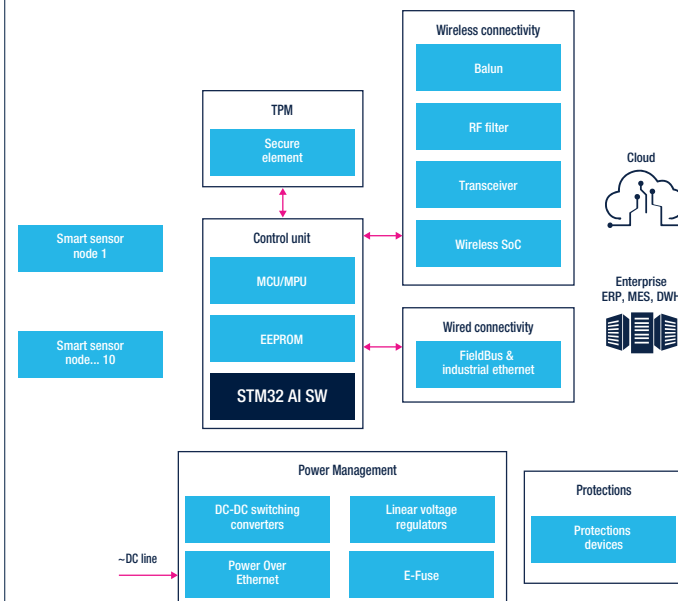

**Smart sensor** nodes are key enablers of predictive analysis. They gather and log pre-processed, secure data to be displayed in visualization tools and used in other processing algorithms. Smart sensor nodes can also process data and detect anomalies by reducing computational latency. For example, smart sensor nodes can detect a small rise or a sudden increase in temperature indicating a probable device issue and future reliability problems.

**Gateways** are either implemented to collect and process data from several smart sensor nodes or to act as a connectivity bridge to enable secure connection to the cloud using ethernet, Wi-Fi, cellular or LPWAN technologies.

**Edge processing** combines and distributes processing power among smart sensor nodes and gateways with the aim of sending the right data at the right time to enterprise-level systems where more advanced analyses can be performed. Processing at the Edge can also use Machine Learning and Artificial Intelligence (AI) algorithms to enhance smart sensor node and gateway mission profiles and to broaden the scope of anomaly detection and classification.

# Key Products

## ST SENSORS FOR INDUSTRY 4.0 - A COMPLETE PORTFOLIO

ST offers high-performance, cost-competitive sensors and Inertial Measurement Units (IMUs) with 10-Year Product Longevity Commitment, including Vibration Sensors and ultra-sound analog microphones enabling vibration analysis from simple Pass/Fail monitoring to high-accuracy, frequency-based data analysis. Our portfolio also includes a wide range of environmental sensors for temperature, humidity and pressure sensing and smart MEMS Sensors with advanced programmable digital features such as Finite State Machine and the Machine Learning Core. Thanks to Unico-GUI framework, smart sensors can be programmed to identify patterns implementing AI algorithms (decision tree) in a local classification engine. This offloads computation from the main controller, allowing it to focus on high level processing and enables the possibility to explore more power efficient architectures, bringing unprecedented value also in terms of overall system cost.

Vibration	
IIS3DWB *	Ultra-wide bandwidth (up to 6kHz), low-noise 3-axis digital Vibration sensor
ISM330DHCX *	Wide Bandwidth Accelerometer + Gyroscope with Machine Learning Core
IIS2ICLX *	High-accuracy, high-resolution, low-power, 2-axis digital inclinometer with Machine learning core
IIS2MDC *	Low-Noise, Low Power Magnetometer
ISM330DLC *	iNEMO inertial measurement unit (IMU): 3D accelerometer and 3D gyroscope with digital output

Acoustic	
IMP23ABSU *	Analog bottom port microphone with frequency response up to 80kHz for Ultrasound analysis
IMP34DT05	Digital Top Port Microphone

Environmental	
LPS22HH	High Accuracy – Compact Size Absolute Pressure Sensor
LPS27HHW LPS27HTW LPS33W	Water Resistant Absolute Pressure Sensor
STTS22H *	Digital Temperature Sensor
STLM20	Analog Temperature Sensor
HTS221	Relative humidity and temperature Sensor



Note: \* 10 years longevity

## STM32: 32-BIT MCUS AND MPUS

ST offers a large portfolio of STM32 Arm® Cortex® from M0 to M7-based microcontrollers addressing many different markets. The STM32 products can be effectively used to develop embedded AI solutions, thanks to the **STM32 AI** framework, and thanks to a broad ecosystem of Partners to ease the implementation of Predictive Maintenance algorithms on MCU and MPU edge devices.

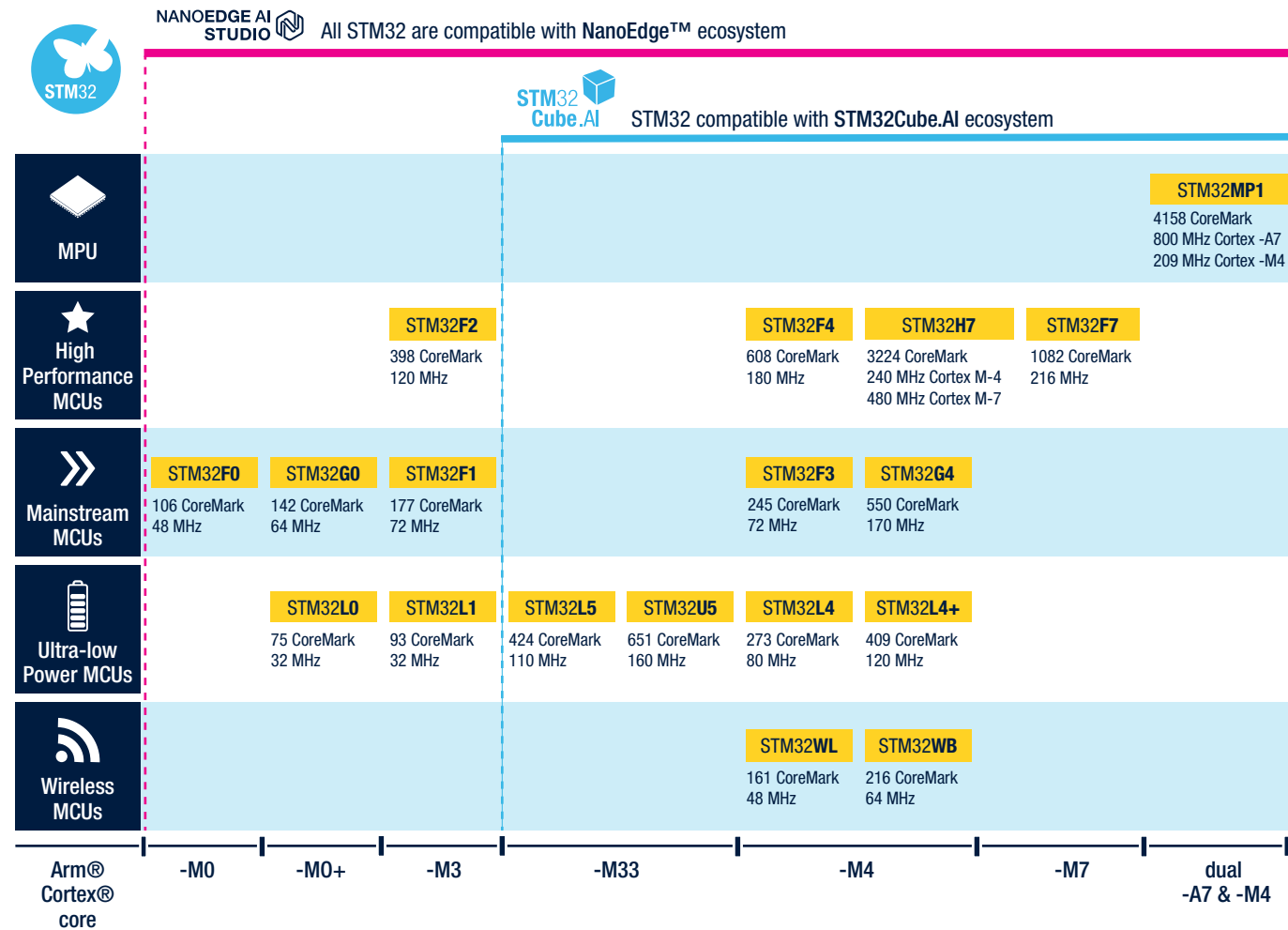

## THE BENEFIT OF EDGE PROCESSING AND THE ROLE OF AI

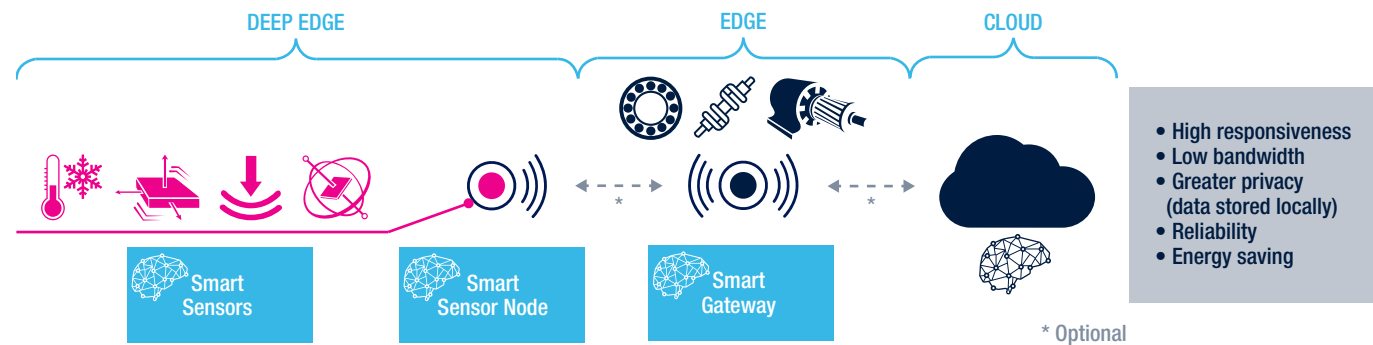

Condition Monitoring and Predictive Maintenance systems include a several smart sensor nodes in the equipment, which are directly connected to the cloud or connected via intermediate gateways. Computation is performed inside the smart sensor or on the local microprocessor, either in gateways or in the cloud, depending on the expected latency and on how far the raw data and processed data are sent over connectivity. Edge processing occurs when the computation of data is carried out directly in the smart sensor node or at the gateway, in order to save power consumption and ensure data is kept confidential, allowing companies to analyze critical information at the node level and to reduce anomaly detection time. Combining edge and cloud computing technologies could help to develop predictive maintenance techniques and enhance their efficiency and effectiveness. Indeed, working on data at the edge, close to the sensor, allows companies to detect machine deterioration at the node level and to take immediate and informed corrective actions, thus preventing further damage and machine failures. Long-term analysis and actions to determine trends and optimize local analysis models can be managed on the cloud, enabling more complex analytics on large amounts of pre-processed data coming from multiple nodes.

Benefits of Edge processing:

**Confidentiality:** data is not sent to the cloud and is locally stored on the device or the equipment

**Cost reduction:** latency and throughput of high-volume time-series asset data is significantly optimized. Reducing the amount of useless machine data sent and stored in the cloud leads to significant benefits, as it enables real-time distributed applications and eliminates the need for complex systems.

**Lower latency:** minimal delay in the repair of equipment is essential for assets which are mission-critical.

Processing at the Edge can also use **Artificial Intelligence (AI)** such as **Machine Learning (ML)** algorithms to enhance smart sensor node and gateway mission profiles and to broaden the scope of anomaly detection and classification.

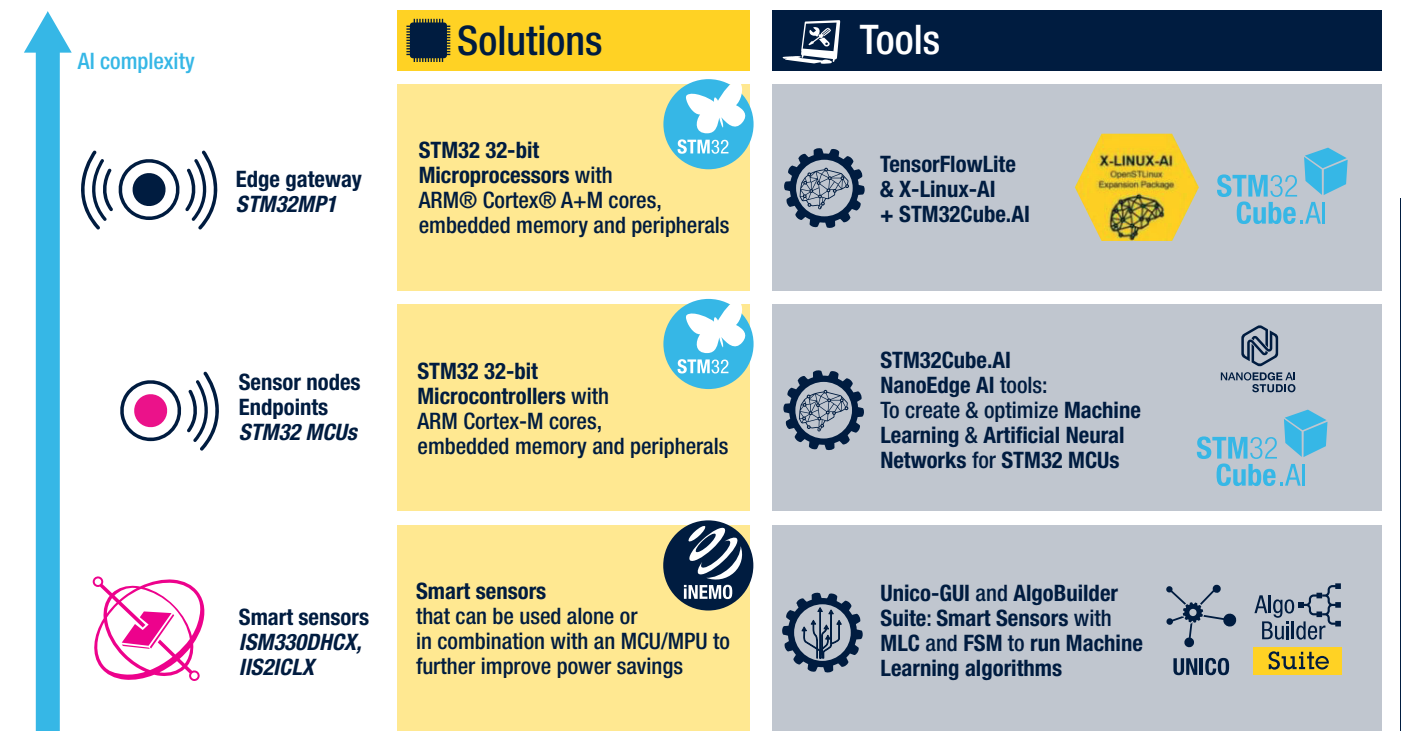

NanoEdge™ AI Studio\* (NanoEdgeAIStudio) is a new Machine Learning (ML) technology to bring true innovation easily to the end-users. In just a few steps, developers can create an optimal ML to address anomaly learning, detection and classification, regression and outliers library for their project, based on a minimal amount of data. NanoEdge™ AI Studio makes it easier for users to integrate such cutting-edge machine-learning capabilities quickly, easily, and cost-effectively into their equipment. No Machine learning or data-science expertise is needed.

**NANOEDGE AI STUDIO**

\*It is available under 3-months evaluation license for free experiments, for more info (hyperlink to <https://www.st.com/en/development-tools/nanoedgeaistudio>).

## CONNECTIVITY SOLUTIONS

Connectivity is an increasingly important aspect of condition monitoring, as data is only useful if it can be actioned. Wireless connectivity technologies have developed enormously in recent years, spurred on by the IoT and, now, the Industrial IoT (IIoT) which is primarily where condition monitoring resides. A range of wired and wireless communication solutions complement our offer: IO-Link-compatible devices for industrial wired connectivity, and a portfolio of wireless technology such as Bluetooth Low Energy SoCs and network processors, as well as LPWAN SoCs and transceivers supporting LoRa, Sigfox and license-free ISM and SRD frequency bands.

NFC & RFID	
ST25DV-I2C	Dynamic NFC / RFID tags

Bluetooth Low Energy	
BlueNRG-LP	Programmable Bluetooth® LE 5.2 Wireless SoC
BlueNRG-2	Highly energy-efficient Bluetooth 5.2 Wireless SoC
STM32WB	Multi-protocol (Bluetooth 5.0 / 802.15.4) Wireless SOC with integrated balun
BALF-NRG-02D3 MLPF-WB55-0xE3	Balun & Filter
BlueNRG-M2	Wireless SoC module for Bluetooth 5.2

Sub-1 GHz	
BALF-SPI2-01D3	Balun for S2-LP
STM32WL	STM32 Sub-1 GHz SOC LoRa/Sigfox compatibility
S2-LP	Ultra-low power, high performance, sub-1GHz transceiver
S2-LPTX	Ultra-low power, high performance, sub-1GHz transmitter

Wired Connectivity	
L6364	IO-LINK Dual Device transceiver
STR485	low power differential line transceiver for data transmission standard RS485 applications in half-duplex mode

**IO-Link**

Cellular	
Cellular connectivity	

NB-IoT LTE-M

WPAN	
STM32WB	Bluetooth LE 5, Zigbee, Thread, proprietary Wireless SOC (integrated balun)

LoRa LoWPAN

## POWER MANAGEMENT

ST is a leading supplier in power management and mixed-signal ICs for mobile applications, offering a wide range of products from simple power management ICs up to highly-integrated devices that mix power management blocks with advanced analog and digital functionalities.

DC/DC converters	
ST1PS0X	400 mA Nano-Quiescent™ Synchronous step-down converters
L7983	60 V 300 mA Synchronous step-down switching regulator with 10 $\mu$ A quiescent current
L6983	38 V 3 A Synchronous step-down converter with 17 $\mu$ A quiescent current
L6981	38 V 1.5 A synchronous step-down converter with low quiescent current

Low Dropout (LDO) Linear Regulators	
STLQ020	200 mA ultra-low quiescent current LDO
LDLN030	300 mA ultra-low noise LDO with power good and soft start
LDLN025	250 mA ultra-low noise LDO
LD59030	300 mA very low dropout current linear regulator IC
LD39130S	300 mA very low quiescent current, with green mode linear regulator IC
LD57100	1A ultra low drop, with bias, linear regulator IC

## CURRENT SENSE

ST's current sense amplifier IC portfolio offers a large variety of high-performance devices. Current sensing solutions add valuable safety and protection features to system designs. They provide information to control current in power systems and avoid overheating and short circuits, enabling Motor Current Signal Analysis with specific processing like FFT Advantages complementary respect to Vibration Analysis.

### High-side

- if ground line cannot be cut (return to neutral by chassis)
- if multiple outputs power supply (all currents are combined in Gnd line)
- if application is sensitive to RF disturbances and requires Gnd line continuity

### ST solution

TSC series  
STEVAL-AETKT1V2 : Evaluation kit for high voltage bidirectional current sense amplifiers



### Low side

- no need for high voltage silicon technology
- more accurate measurement

### ST solution

TSZ: very high-accuracy zero drift 5 V op amps  
TSV79: 50 MHz-bandwidth 5 V op amps

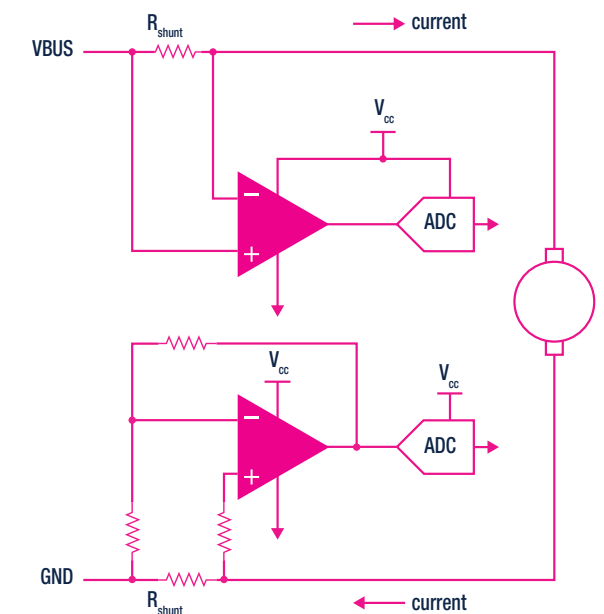

# ST Solutions

## FROM CBM TO PDM FOLLOW YOUR PATH WITH ST SOLUTIONS

ST provides different hardware and software solutions to help designers in their job. Starting from the Product Evaluation Boards, that can be used to perform a comprehensive evaluation of ST's products, arriving to the **Solution** tailored to exploit one or more features of the application with a kit of HW and SW packages.

Particularly for Condition Based Monitoring, the set of tools allow to move step by step along the development flow.

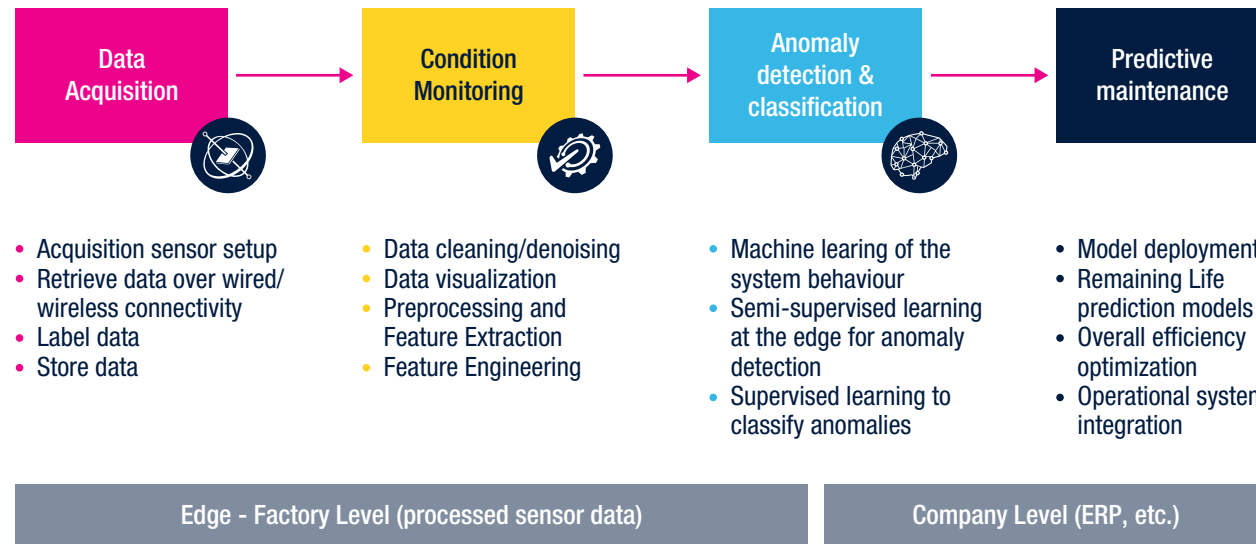

## DESIGN SUPPORT HARDWARE REFERENCE DESIGN AND DEVELOPMENT KITS

STMicroelectronics has developed smart sensor nodes and SW packages to emulate a typical architecture where smart sensor nodes can be either connected with Gateway or directly with WPAN connectivity to the data lake on premise or in Cloud application. Particularly two families of smart sensor nodes have been developed in a typical IO Link sensor to Master vertical integration (STEVAL-BFA001V2B) or wireless node with multi connectivity options from Bluetooth, to WIFI, to Cellular (STEVAL-STWINKT1B). Related SW for IO Link stack, vibration analysis, cloud application and much more complete the offer with following solutions.

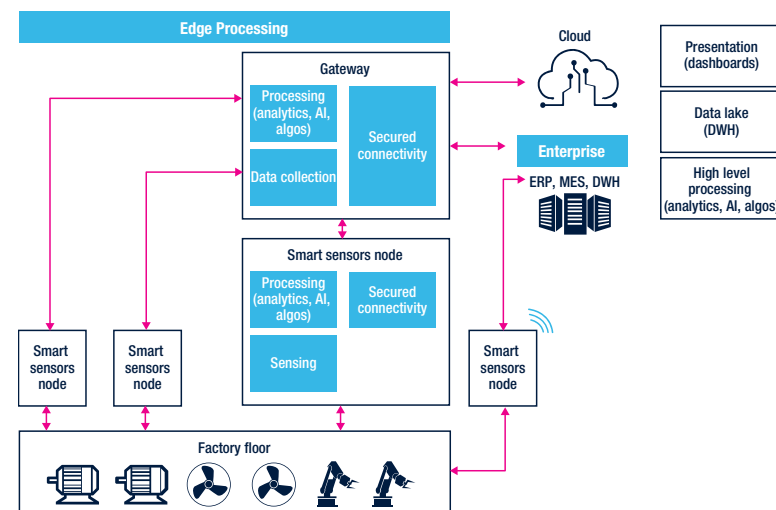

Data Acquisition

Condition Monitoring

ST offers a broad range of solutions. Solutions are presented as a set of products that enable our customers to deliver best performance with cutting edge technology in their application domain. Our solutions are offered at many different levels, varying from basic functional elements of an application to entire subsystems where appropriate.

Each solution is accompanied by a solution evaluation kit, allowing rapid evaluation of the products, within a proven design, in order to accelerate your prototyping and development process.



**HW Component**  
STEVAL-BFA001V2B

**SW Component**  
STSW-BFA001V2

### SL-BFA001V2

Sensor node with IO-Link device stack for predictive maintenance and condition monitoring



**HW Component**  
STEVAL-STWINKT1B

**SW Component**  
FP-SNS-DATALOG1  
ST BLE SENSOR APP

### High Speed Data Logging

STWIN wireless industrial node development kit combined with High-Speed Data Logger software package, BLE Mobile APP and integrated Host Environment to greatly simplifying the acquisition process



**HW Component**  
STEVAL-STWINKT1B  
STEVAL-STWINWFV1

**SW Component**  
FP-CLD-AWS1  
FP-CLD-AZURE

### Cloud and Features Demonstration

FP-CLD-AZURE1 :Cloud Connectivity SDK and Application for fast implementations

FP-CLD-AWS1: Offer examples of Security Features



## SOLUTION END TO END

Data Acquisition

Condition  
Monitoring



### HW Component

STEVAL-STWINKT1B  
STEVAL-STWINWFV1  
P-L496G-CELL02

### SW Component

DSH-PREDMNT  
FP-IND-PREDMNT1  
STSW-STWINCELL

### SL-PREDMNT-S2C

A Condition monitoring sensor to cloud for vibration analysis with WIFI and Cellular Connection



### HW Component

STM32MP157C-DK2  
STEVAL-IDP004V2  
STEVAL-BFA001V2

### SW Component

DSH-PREDMNT  
X-LINUX-PREDMNT  
STSW-BFA001V2 /  
STSW-IPD4PREDMNT

### SL-PREDMNT-E2C

A Condition monitoring sensor to cloud for vibration analysis with WIFI and Cellular Connection

## SOLUTIONS FOR ANOMALY DETECTION

Data Acquisition

Condition  
Monitoring

Anomaly detection  
@ the Edge



### HW Component

STEVAL-STWINKT1B  
STM32L562E-DK

### SW Component

FP-AI-NANOEDG1  
FP-AI-PREDMNT2  
FP-AI-MONITOR1  
DSH-PREDMNT2  
NANOEDGE AI Studio  
NANOEDGE AI STUDIO 

Anomaly Detection with NanoEdge Studio



Order code: BR2112PREDMAINT

For more information on ST products and solutions, visit [www.st.com](http://www.st.com)

© STMicroelectronics - December 2021 - Printed in the United Kingdom - All rights reserved  
ST and the ST logo are registered and/or unregistered trademarks of STMicroelectronics International NV or its affiliates in the EU and/or elsewhere. In particular, ST and the ST logo are Registered in the US Patent and Trademark Office. For additional information about ST trademarks, please refer to [www.st.com/trademarks](http://www.st.com/trademarks).  
All other product or service names are the property of their respective owners.

