

Datasheet

# Cellular IoT Module with BLE

**AES-CELLIOT-AVT9152MOD**

## FEATURES

### Cellular IoT (Nordic nRF9160)

- 3GPP R13 Cat-M1 & NB1 compliant
- 3GPP R14 NB1 & NB2 compliant
- Output power: -40dBm to 23 dBm
- -108 dBm sensitivity (LTE-M)
- -114 dBm sensitivity (CAT-NB1/NB2)
- B3, B4, B13, B20 (Cat-M1)
- B3, B20 (NB1)
- GPS antenna port for active/passive antenna
- ARM® Cortex® -M33
- ARM® TrustZone®
- IPv4, IPv6 stack
- 1 MB flash and 256 kB RAM
- Supports SIM or eSIM
- Up to 10 GPIOs
- Up to 4 ADC Inputs
- SPI
- I2S
- UART

### BLE (Nordic nRF52840)

- BT5.0
- Output power: -20dBm to +8dBm
- -95 dBm sensitivity (1Mbps BLE mode)

- On-board chip antenna for BLE
- ARM® Cortex®-M4 32-bit processor with FPU, 64 MHz
- ARM® TrustZone®
- 1 MB flash and 256 kB RAM
- NFC
- USB 2.0
- Up to 13 GPIOs
- Up to 4 ADC Inputs
- SPI
- I2S
- UART

### General

- 26 x 28 x 3 mm
- Operating voltage: 3.2 to 5V

### Applications

- Logistic & asset tracking
- Vending machine
- POS terminal
- Smart building automation
- Medical devices
- Beacon based application

## Table of Contents

1. Description .....	5
2. Block Diagram .....	6
3. PIN Assignments .....	7
3.1. Edge Connector .....	7
3.2. GPS Receiver Input Connector .....	10
3.3. Interconnects between nRF9160 and nRF52840 .....	10
3.4. VDD_Supply Voltage Measurement .....	11
3.5. System Voltage Monitor .....	11
4. Absolute Maximum Ratings .....	12
5. Electrical Specifications .....	12
6. Bluetooth Antenna Performance .....	15
6.1. Antenna Radiation Measurements .....	15
6.2. Antenna Radiation Patterns .....	15
7. Mechanical Specifications .....	17
7.1. Mechanical Dimensions .....	17
7.2. Recommended Footprint .....	18
8. Design Guidelines .....	19
9. Reference Circuitry .....	21
10. Application Example – Tracking Device .....	22
11. Regulatory Information .....	23
11.1. FCC .....	23
11.2. BQB .....	25
12. Order Information .....	26
12.1. Order Information .....	26
12.2. Module Label .....	26
13. Storage, Packaging and Manufacturing .....	27
13.1. Storage .....	27
13.2. Packaging .....	27
13.3. Manufacturing .....	28
14. Legal Notice .....	29
15. Contact Information .....	32

16. Revision History ..... 33

## List of Figures

Figure 1: AVT9152 Module ..... 5  
Figure 2: AVT9152 Block Diagram..... 6  
Figure 3: AVT9152 Pin Assignment ..... 7  
Figure 4:  $\mu$ .FL conenctor (J1) for GPS Receiver ..... 10  
Figure 5: Bluetooth Antenna Radiation Test Setup ..... 15  
Figure 6: Bluetooth Antenna Radiation Patterns..... 16  
Figure 7: AVT9152 Mechanical Dimensions..... 17  
Figure 8: AVT9152 Recommended Footprint ..... 18  
Figure 9: No Copper Area on Host PCB..... 19  
Figure 10: Recommended Matching Network for Non-50 $\Omega$  LTE Antenna ..... 19  
Figure 11: Recommended Matching Network for 50 $\Omega$  LTE Antenna ..... 20  
Figure 12: Recommended Matching Network for 50 $\Omega$  LTE Antenna ..... 20  
Figure 13: Reference Schematic ..... 21  
Figure 14: Example of Tracking Device using AVT9152 ..... 22  
Figure 15: AVT9152 Label ..... 26  
Figure 16: Tape Dimensions (Unit: mm) ..... 28  
Figure 17: Reflow Profile..... 28

## 1. Description

This module supports IoT applications that require both NB-IoT and BLE connectivity by utilizing industry-leading low power devices from Nordic - nRF9160-SICA and nRF52840-QIAA.

It is specifically designed for direct connection to the battery as its power source. The on-board BLE antenna provides ease of development, while the NB-IoT antenna feed is pulled to the edge for maximum end product packaging flexibility. Options are available for either passive or active GPS antenna.

Both nRF9160 and nRF52840 come with ARM® processor and 1 MB flash, 256 kB RAM. GPIOs, ADCs, I2S, SPI and UARTs interfaces from both ICs are made available at the module's edge connectors.

The 2 ICs are interconnected with IOs for signaling. User has the flexibility of selecting either one of the IC to be the device Master.

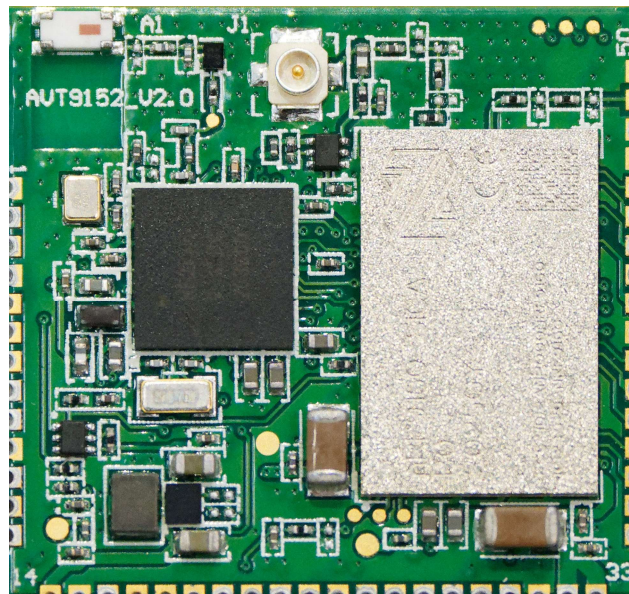

*Figure 1: AVT9152 Module*

## 2. Block Diagram

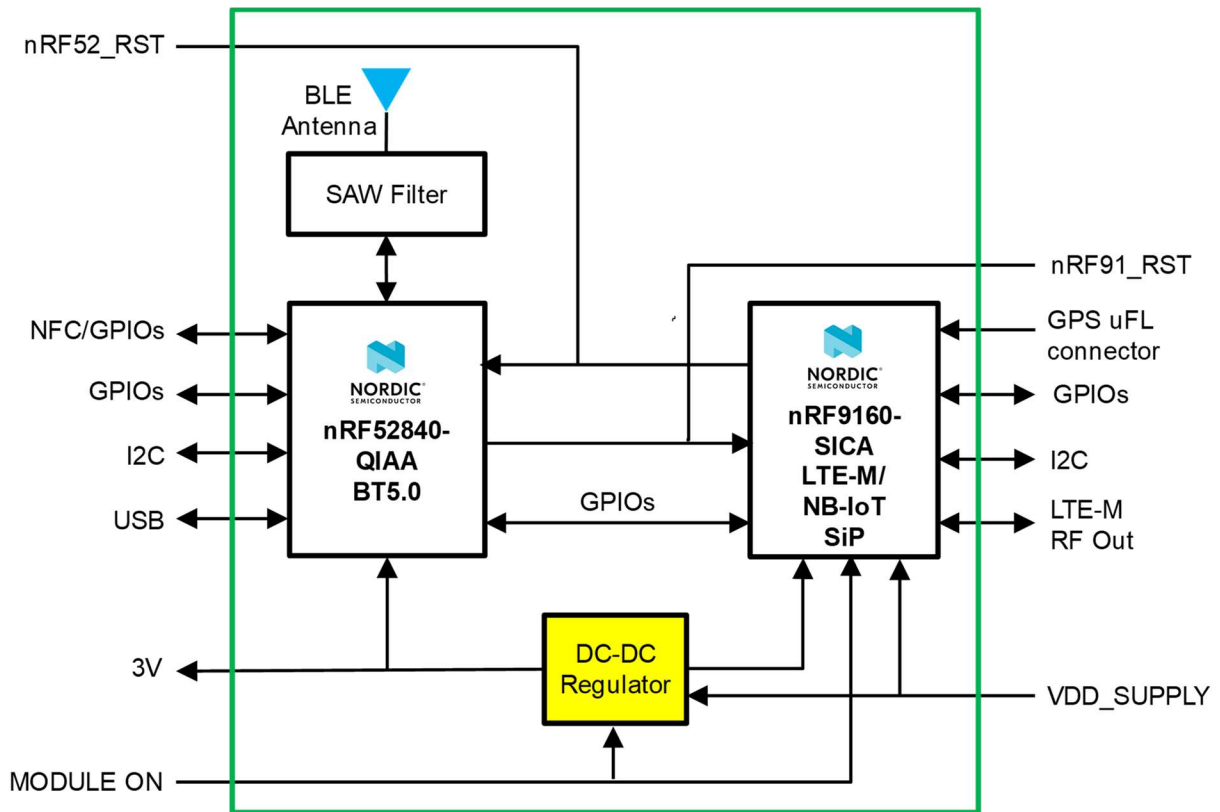

Figure 2: AVT9152 Block Diagram

3. PIN Assignments  
 3.1. Edge Connector

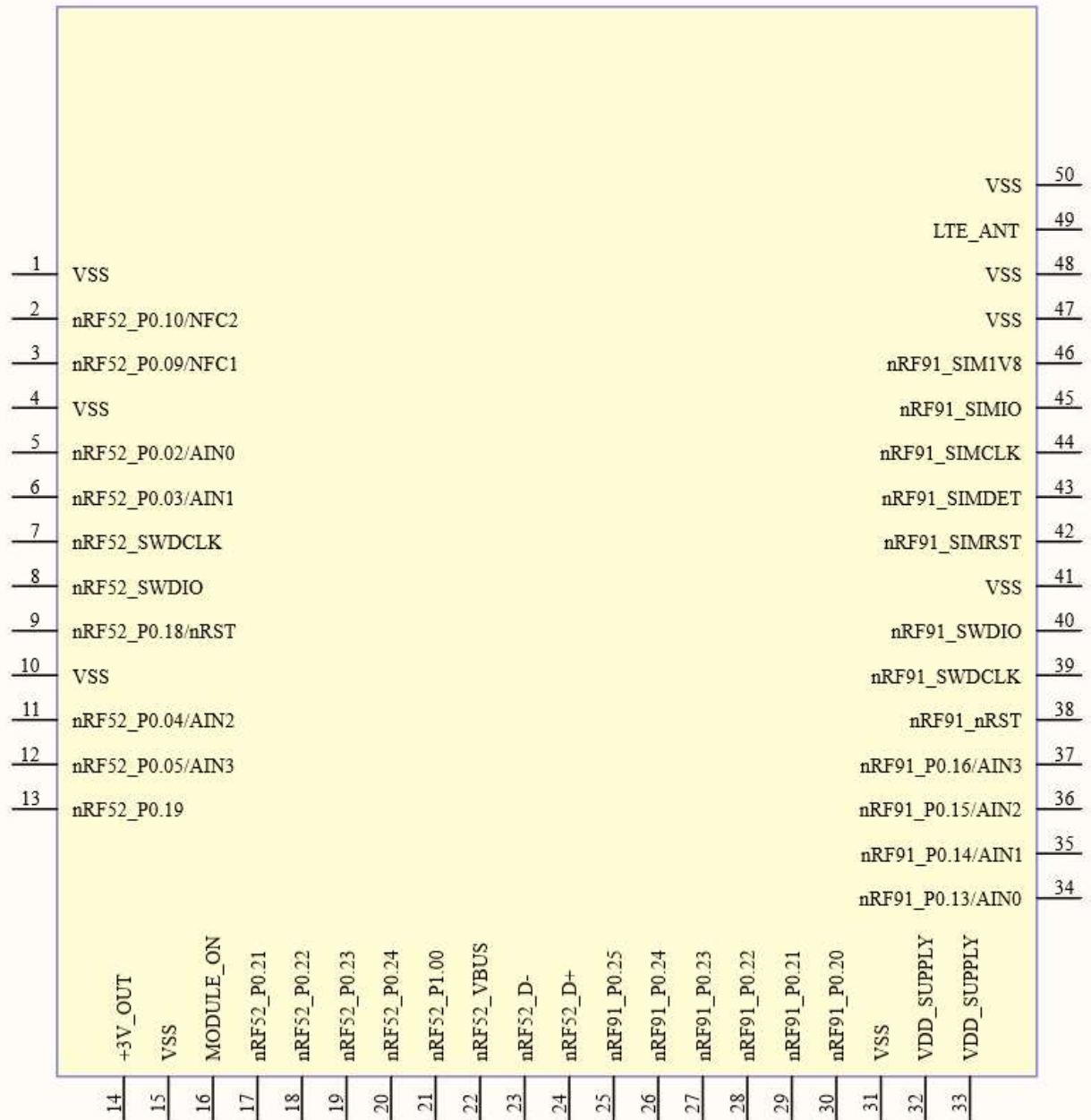

Figure 3: AVT9152 Pin Assignment

## Pin Descriptions

Pin Number	Pin Name	Pin Type	Description
1	VSS	GND	Ground
2	nRF52_P0.10/NFC2	DIO/AI	nRF52 General-purpose digital I/O/ NFC Antenna Input
3	nRF52_P0.09/NFC1	DIO/AI	nRF52 General-purpose digital I/O/ NFC Antenna Input
4	VSS	GND	Ground
5	nRF52_P0.02/AIN0	DIO/AI	nRF52 General-purpose digital I/O/ Analog Input
6	nRF52_P0.03/AIN1	DIO/AI	nRF52 General-purpose digital I/O/ Analog Input
7	nRF52_SWCLK	DI	nRF52 Debug Port Clock
8	nRF52_SWDIO	DIO	nRF52 Debug Port Data
9	nRF52_P0.18/nRST	DIO/DI	nRF52 General-purpose digital I/O/ Reset Input (active low)
10	VSS	GND	Ground
11	nRF52_P0.04/AIN2	DIO/AI	nRF52 General-purpose digital I/O/ Analog Input
12	nRF52_P0.05/AIN3	DIO/AI	nRF52 General-purpose digital I/O/ Analog Input
13	nRF52_P0.19	DIO	nRF52 General-purpose digital I/O
14	+3V_OUT	PWR	+3V, 200mA power output from module
15	VSS	GND	Ground
16	MODULE_ON	PWR	Module Power On Input. Connect to VDD_SUPPLY to turn on the module, VSS to turn off the module.
17	nRF52_P0.21	DIO	nRF52 General-purpose digital I/O
18	nRF52_P0.22	DIO	nRF52 General-purpose digital I/O
19	nRF52_P0.23	DIO	nRF52 General-purpose digital I/O/ Analog Input
20	nRF52_P0.24	DIO	nRF52 General-purpose digital I/O/ Analog Input
21	nRF52_P1.00	DIO	nRF52 General-purpose digital I/O/ Analog Input
22	nRF52_VBUS	PWR	nRF52 USB Port Power Input
23	nRF52_D-	USB	nRF52 USB negative port
24	nRF52_D+	USB	nRF52 USB positive port
25	nRF91_P0.25	DIO	nRF91 General-purpose digital I/O
26	nRF91_P0.24	DIO	nRF91 General-purpose digital I/O
27	nRF91_P0.23	DIO	nRF91 General-purpose digital I/O
28	nRF91_P0.22	DIO	nRF91 General-purpose digital I/O
29	nRF91_P0.21	DIO	nRF91 General-purpose digital I/O
30	nRF91_P0.20	DIO	nRF91 General-purpose digital I/O



Pin Number	Pin Name	Pin Type	Description
31	VSS	GND	Ground
32	VDD_SUPPLY	PWR	3.2V – 5V power supply to module
33	VDD_SUPPLY	PWR	3.2V – 5V power supply to module
34	nRF91_P0.13/AIN0	DIO/AI	nRF91 General-purpose digital I/O/ Analog Input
35	nRF91_P0.14/AIN1	DIO/AI	nRF91 General-purpose digital I/O/ Analog Input
36	nRF91_P0.15/AIN2	DIO/AI	nRF91 General-purpose digital I/O/ Analog Input
37	nRF91_P0.16/AIN3	DIO/AI	nRF91 General-purpose digital I/O/ Analog Input
38	nRF91_nRST	DI	nRF91 Reset Input (active low, open collector/drain)
39	nRF91_SWDCLK	DI	nRF91 Debug Port Clock
40	nRF91_SWDIO	DIO	nRF91 Debug Port Data
41	VSS	GND	Ground
42	nRF91_SIMRST	DO	nRF91 SIM Card Reset Output
43	nRF91_SIMDET	DI	nRF91 SIM Card Presence Detect Input
44	nRF91_SIMCLK	DO	nRF91 SIM Card Clock Output
45	nRF91_SIMIO	DIO	nRF91 SIM Card Data I/O
46	nRF91_SIM1V8	PWR	nRF91 SIM Card Power Supply (1.8V nominal)
47	VSS	GND	Ground
48	VSS	GND	Ground
49	LTE_ANT	RF	nRF91 LTE Antenna Port
50	VSS	GND	Ground

**Note:** Please refer to Nordic nRF52840 and nRF9160 Datasheets and User Guides for detail function of each pin.

### 3.2. GPS Receiver Input Connector

A  $\mu$ .FL conenctor (J1) is provided for user to connect to an external GPS antenna. J1 is connected to GPS receiver input port of nRF9160.

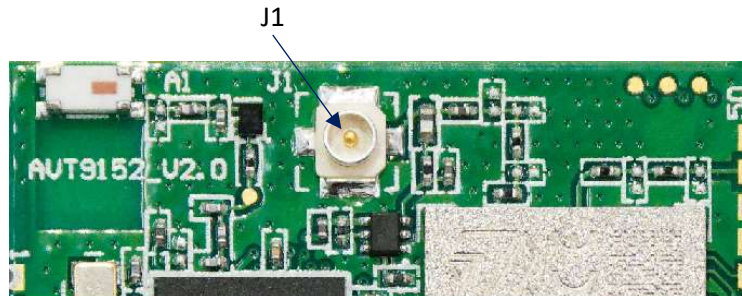

Figure 4:  $\mu$ .FL conenctor (J1) for GPS Receiver

The receiver supports GPS L1/CA reception. In Nordic's white paper "nWP033- nRF9160 Antenna and RF Interface Guidelines", it is recommended to use active GPS antenna with LNA gain >15dB.

A 3V supply is provided to power external active GPS antenna via J1. It can be enabled via setting MAPGIO0 (pin 55 of nRF9160) to high. User may refer to "nRF91 AT Commands" for detail programming of this pin.

### 3.3. Interconnects between nRF9160 and nRF52840

Some interconnecting signals between nRF9160 and nRF52840 had been provided to aid communication/control between the 2 devices.

	<b>nRF9160</b>	<b>nRF52840</b>
<b>GPIOs</b>	nRF91_P0.17	nRF52_P0.15
	nRF91_P0.18	nRF52_P0.17
	nRF91_P0.19	nRF52_P0.20
<b>LTE Modem Coexistence Interface</b>	nRF91_COEX0	nRF52_P1.13
	nRF91_COEX1	nRF52_P1.11
	nRF91_COEX2	nRF52_P1.15
<b>Sub-system Reset</b>	nRF91_nRST	nRF52_P0.13
	nRF91_P0.27	nRF52_nRST

### 3.4. VDD\_Supply Voltage Measurement

The module contains a circuit to measure voltage of VDD\_SUPPLY. A potential divider (1/2) is included to step down input voltage to within voltage limit of ADC input pin.

To take measurement, set P0.27 of nRF52840 IC to “1”, read from P0.31/AIN7 of nRF52840 IC. Actual value is 2x the reading.

Set P0.27 of nRF52840 IC to “0” to turn off the circuit after measurement, to reduce current consumption (~200uA).

### 3.5. System Voltage Monitor

When System voltage (+3V) is below threshold level (2.85V), input to nRF52840 IC's P1.08 will become “0”. To enable this feature, set the pin to “input with pull\_up”.

## 4. Absolute Maximum Ratings

	Min	Max	Unit
Supply Voltage (VDD_SUPPLY)	-0.3	5.5	V
Voltage on any Digital/Analog pin	-0.3	3.3	V
USB Supply Voltage (nRF52_VBUS)	-0.3	5.8	V
LTE Antenna Input RF Level		10	dBm
GPS Antenna Input RF Level		-15	dBm
Storage temperature range	-40	95	°C

## 5. Electrical Specifications

### Module

	Min	Typ	Max	Unit
Supply Voltage (VDD_SUPPLY)	3.2	3.8	5.0	V
USB Supply Voltage (nRF52_VBUS)	4.35	5	5.5	V
Operating Temperature	-40	25	85	°C

### LTE Modem Operation

	Min	Typ	Max	Unit
Frequency Range	699		2200	MHz
Max Output Power (LTE Cat-M/NB1/NB2)		23		dBm
Min Output Power (LTE Cat-M/NB1/NB2)		-40		dBm
Receiver Sensitivity, Low Band (LTE Cat-M)	-103	-108		dBm
Receiver Sensitivity, Mid Band (LTE Cat-M)	-103	-107		dBm
Receiver Sensitivity, Low Band (LTE Cat-NB)	-108	-114		dBm
Receiver Sensitivity, Mid Band (LTE Cat-NB)	-108	-113		dBm
Peak Current Consumption, CAT-M1 TX sub frame, Pout=23dBm, normal operating condition		295		mA
Peak Current Consumption, CAT-NB1 TX sub Frame, Pout=23dBm, normal operating condition		275		mA
Sleep Current Consumption, CAT-M1/NB1, PSM Floor Current		2.7		µA
	Min	Typ	Max	Unit

eDRX average current, 81.92 s, one PO/PTW, PTW = 2.56 s, radio resource control (RRC) mode, Cat-M1		37		μA
Average Current Cat-M1, Uplink 180 kbit/s, Pout 23 dBm, RMC settings as per 3GPP TS 36.521-1 Annex A.2, radio resource control (RRC) mode		115		mA
Average Current Cat-NB1, Pout 23 dBm, BPSK, 1SC, 3.75 kHz, TX 80% RX 10% ("TX intensive"), RMC settings as per 3GPP TS 36.101 Annex A.2.4, radio resource control (RRC) mode		225		mA

### GPS Operation

	Min	Typ	Max	Unit
Acquisition Sensitivity, Cold Start		-145.5		dBm
Acquisition Sensitivity, Hot Start		-147		dBm
Tracking Sensitivity		-155		dBm
Acquisition Time (Time to First Fix (TTFF)), Cold Start, Open Sky, Typical		36		s
Acquisition Time, Hot Start, Open Sky, Typical		1.3		s
Typical Peak Current, Continuous Tracking, without Power Saving Mode		44.9		mA
Current Consumption, Continuous Tracking, Power Saving Mode		9.6		mA
Average Current, Single Shot, One Fix every 2 minutes		2.5		mA

### Bluetooth IC Operation

	Min	Typ	Max	Unit
Frequency Range	2402		2480	MHz
Max Output Power		8		dBm
Min Output Power		-20		dBm
Receiver Sensitivity, 1 Mbps BLE Ideal Transmitter, Packet Length ≤ 37bytes, BER=1E-320		-95		dBm

**DATASHEET**

Transmit Current, Pout=8dBm, 1 Mbps BLE mode, Clock = HFXO, Regulator = DC/DC		16.4		mA
Receive Current, 1 Mbps BLE mode, Clock = HFXO, Regulator = DC/DC		6.26		mA

**Digital/Analog Pins**

	Min	Typ	Max	Unit
Interface Supply Voltage		3.0		V
Input High Voltage	2.1		3.0	V
Input Low Voltage	0		0.9	V
Output High Voltage, Standard Drive 0.5mA, High Drive 5mA	2.6		3.0	V
Output Low Voltage, Standard Drive 0.5mA, High Drive 5mA	0		0.4	V

**Note:** Please refer to Nordic nRF52840 and nRF9160 Datasheets and User Guides for detail characteristics and functions of nRF52840 and nRF9160.

**Output Voltages**

	Min	Typ	Max	Unit
+3V_OUT	2.9	3.0	3.1	V
+3V_OUT Current	0		200	mA
Voltage at J1 (GPS Receiver Input)	2.9	3.0	3.1	V
Output Current at J1	0		25	mA
nRF91_SIM_1V8	1.7	1.8	1.9	V

**Others**

	Min	Typ	Max	Unit
MODULE_ON High Voltage		VDD_SUPPLY		V
MODULE_ON Low Voltage		VSS		V

## 6. Bluetooth Antenna Performance

### 6.1. Antenna Radiation Measurements

#### Peak Gain

Frequency (MHz)	2412	2417	2422	2427	2432	2437	2442	2447	2452	2457	2462	2467	2472	2484
Peak Gain (dBi)	0.92	0.92	0.95	0.90	0.85	0.83	0.82	0.72	0.74	0.74	0.72	0.70	0.66	0.69

#### Average Gain

Frequency (MHz)	2412	2417	2422	2427	2432	2437	2442	2447	2452	2457	2462	2467	2472	2484
Peak Gain (dBi)	-3.08	-3.09	-3.11	-3.16	-3.20	-3.22	-3.24	-3.31	-3.30	-3.32	-3.34	-3.37	-3.41	-3.47

#### Efficiency

Frequency (MHz)	2412	2417	2422	2427	2432	2437	2442	2447	2452	2457	2462	2467	2472	2484
Peak Gain (dBi)	49.23	49.05	48.81	48.30	47.89	47.60	47.42	46.68	46.82	46.61	46.31	46.08	45.56	44.96

### 6.2. Antenna Radiation Patterns

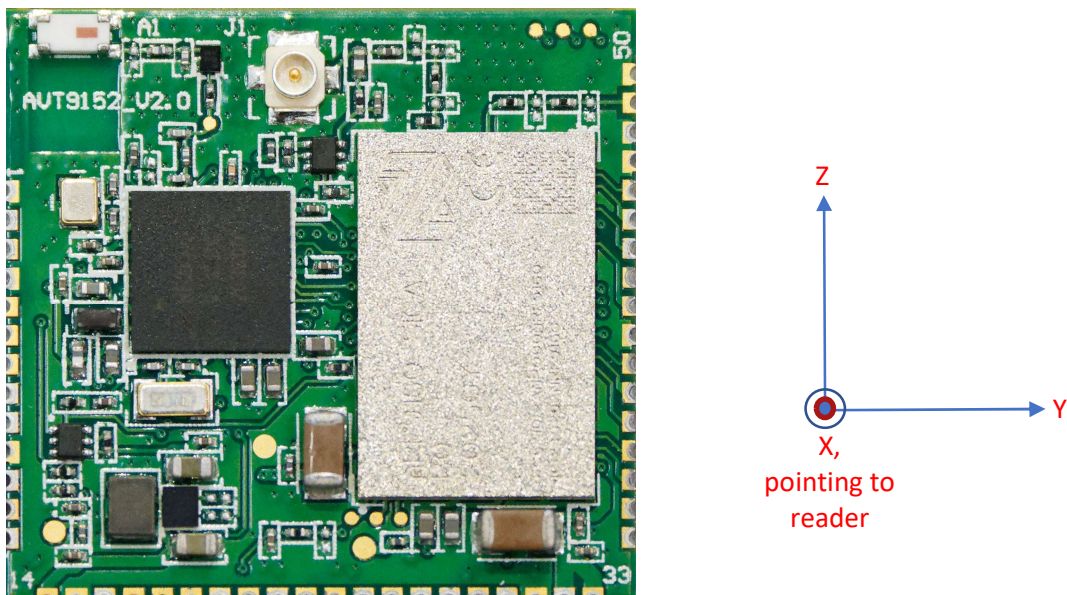

Figure 5: Bluetooth Antenna Radiation Test Setup



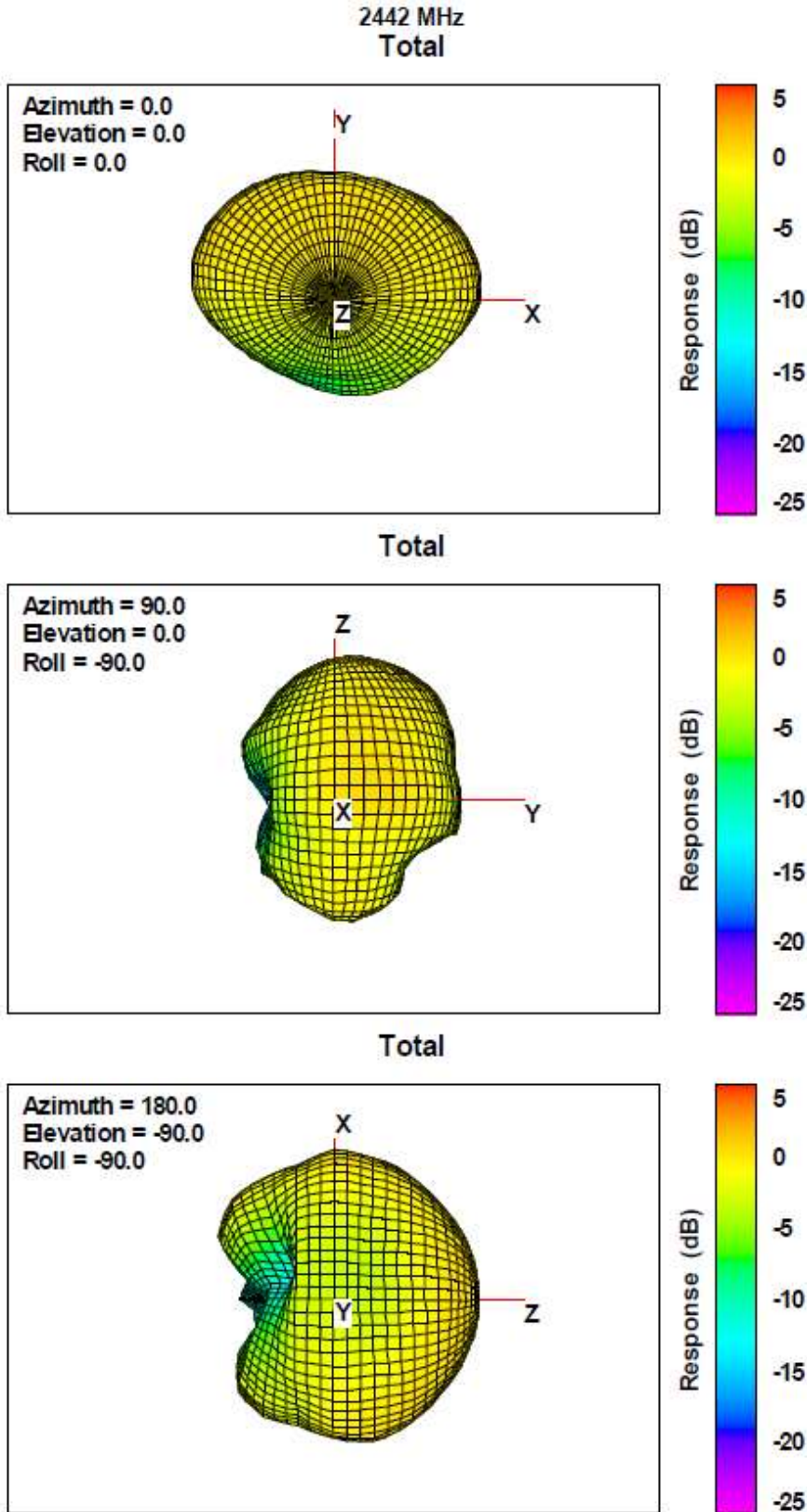

Figure 6: Bluetooth Antenna Radiation Patterns



## 7. Mechanical Specifications

### 7.1. Mechanical Dimensions

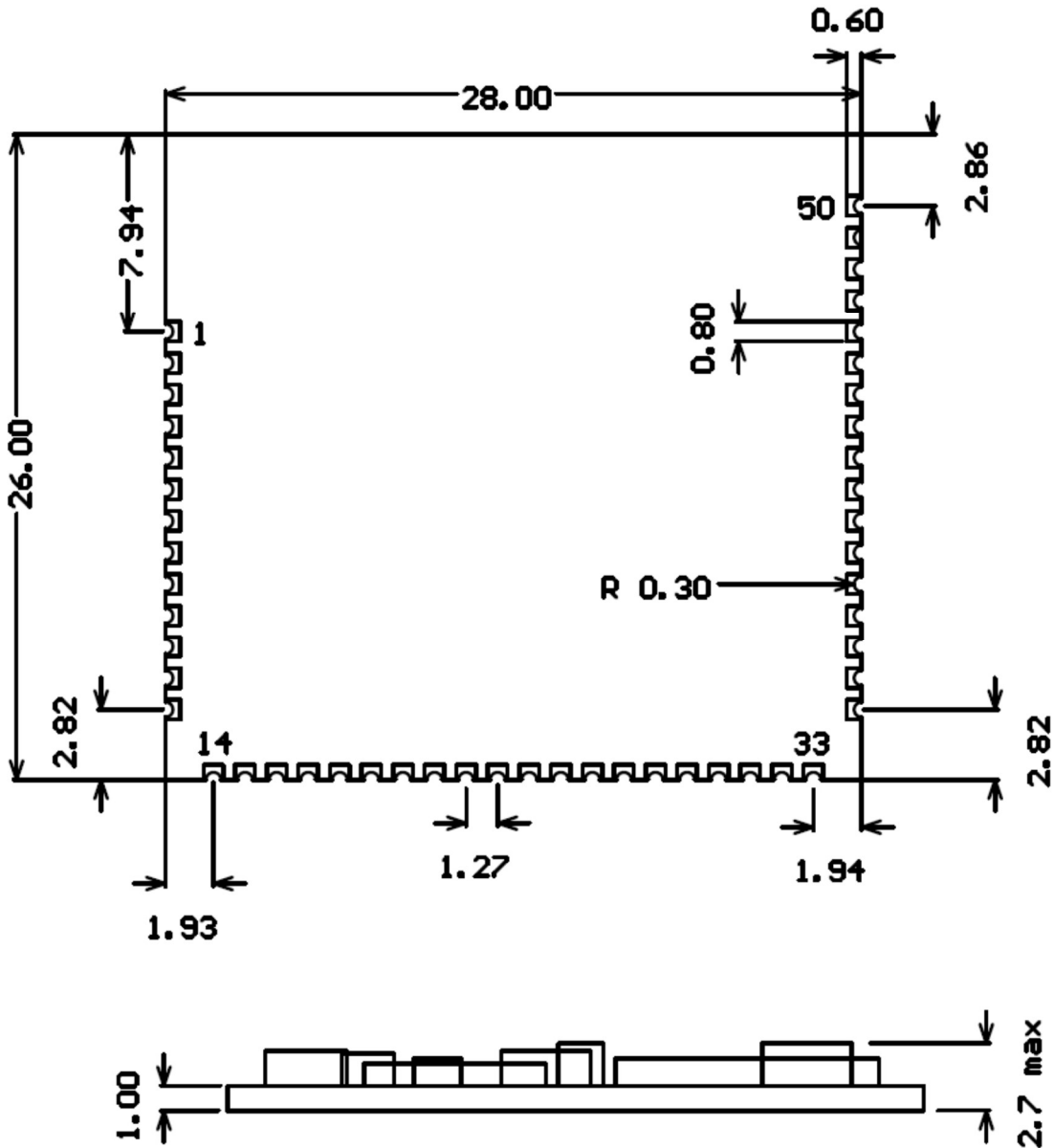

Figure 7: AVT9152 Mechanical Dimensions

7.2. Recommended Footprint

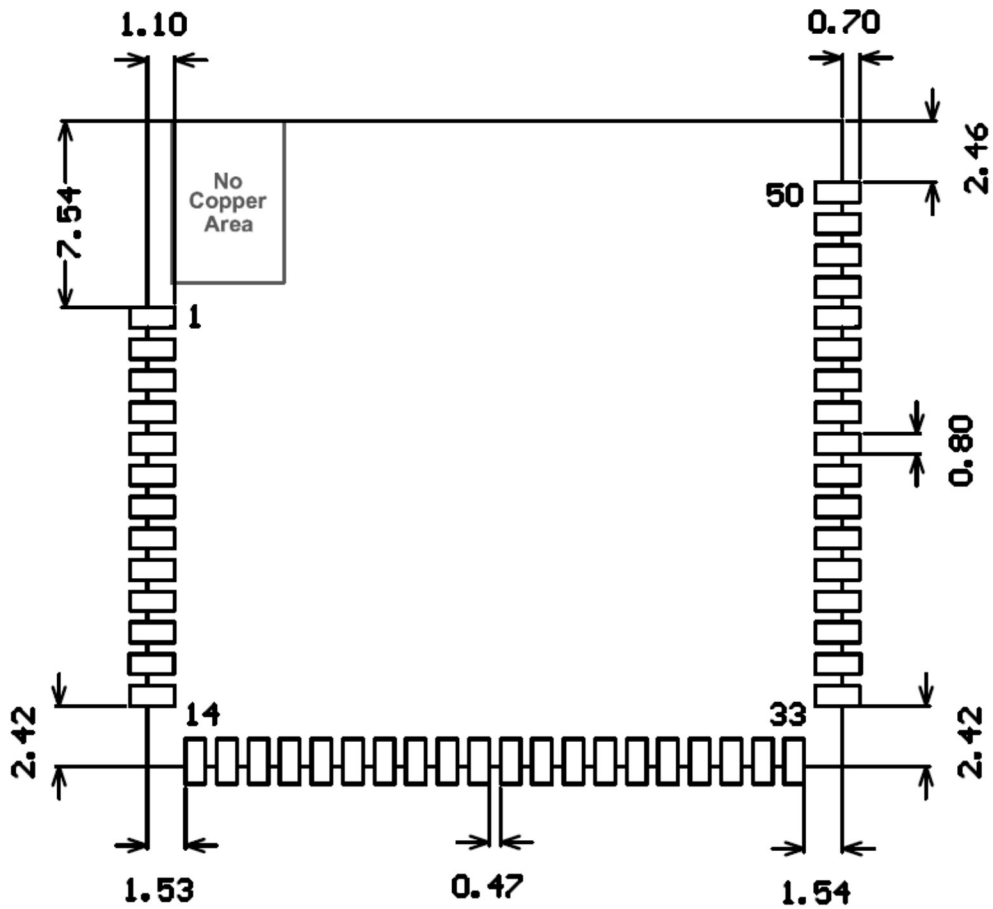

Figure 8: AVT9152 Recommended Footprint

## 8. Design Guidelines

Please take note of following guidelines when designing Host PCB:

- There should be no copper pattern at the area underneath Bluetooth SMD antenna, on all layers of Host PCB. Orientate the Module with the “no-copper area” at one corner of Host PCB, so that Bluetooth signal radiated from the SMD antenna is not blocked by adjacent components.

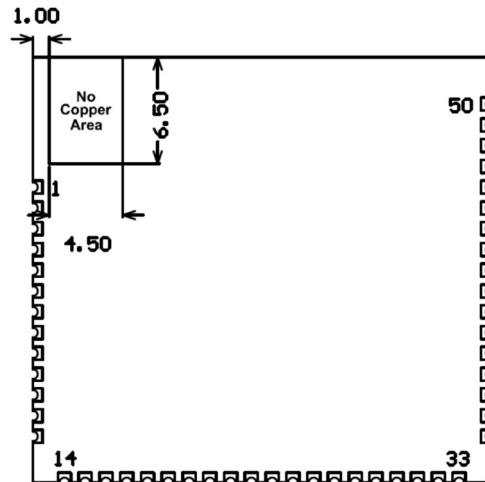

Figure 9: No Copper Area on Host PCB

- There are some exposed test pads at bottom side of module, for internal testing purpose. Cover all patterns and via holes with solder mask on Host PCB, on the layer that is immediately below the Module, to avoid shorting with test pads above them.
- The pin LTE\_ANT on Module's edge connector is for connection to customer's choice of LTE antenna. The RF trace on Host PCB connecting to this pin should be of 50Ω impedance.
- If LTE antenna is not a 50Ω antenna, e.g. FPC or SMD antenna, place up to 4 segments of R-C matching network between LTE\_ANT and antenna. The matching components should be placed as close to antenna as possible. Default values of R1, R2, R3 and R4 are 0Ω while C1, C2, C3 and C4 are not mounted. User can optimize their values with antenna and casing in place.

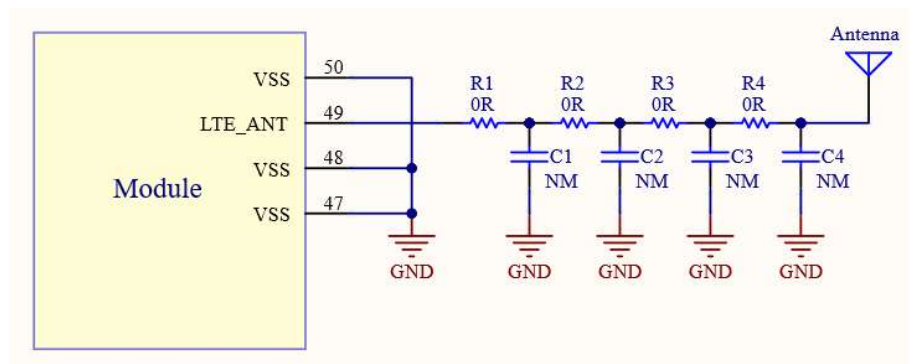

Figure 10: Recommended Matching Network for Non-50Ω LTE Antenna

- If LTE antenna is of external swivel type, it is probably a 50Ω antenna. A  $\pi$  matching network (C1/R1/C2) between LTE\_ANT and antenna will be adequate. The matching components should be placed as close to antenna as possible. Default values of R1 is 0Ω while C1 and C2 are not mounted. User can optimize their values with antenna and casing in place.

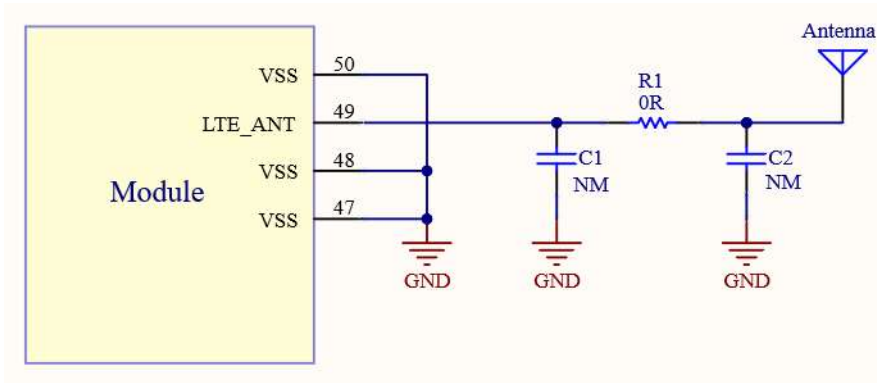

Figure 11: Recommended Matching Network for 50Ω LTE Antenna

- It is recommended to include a series resistor on the USB supply for improved immunity to transient overvoltage during VBUS connection.

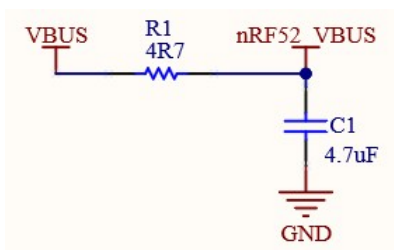
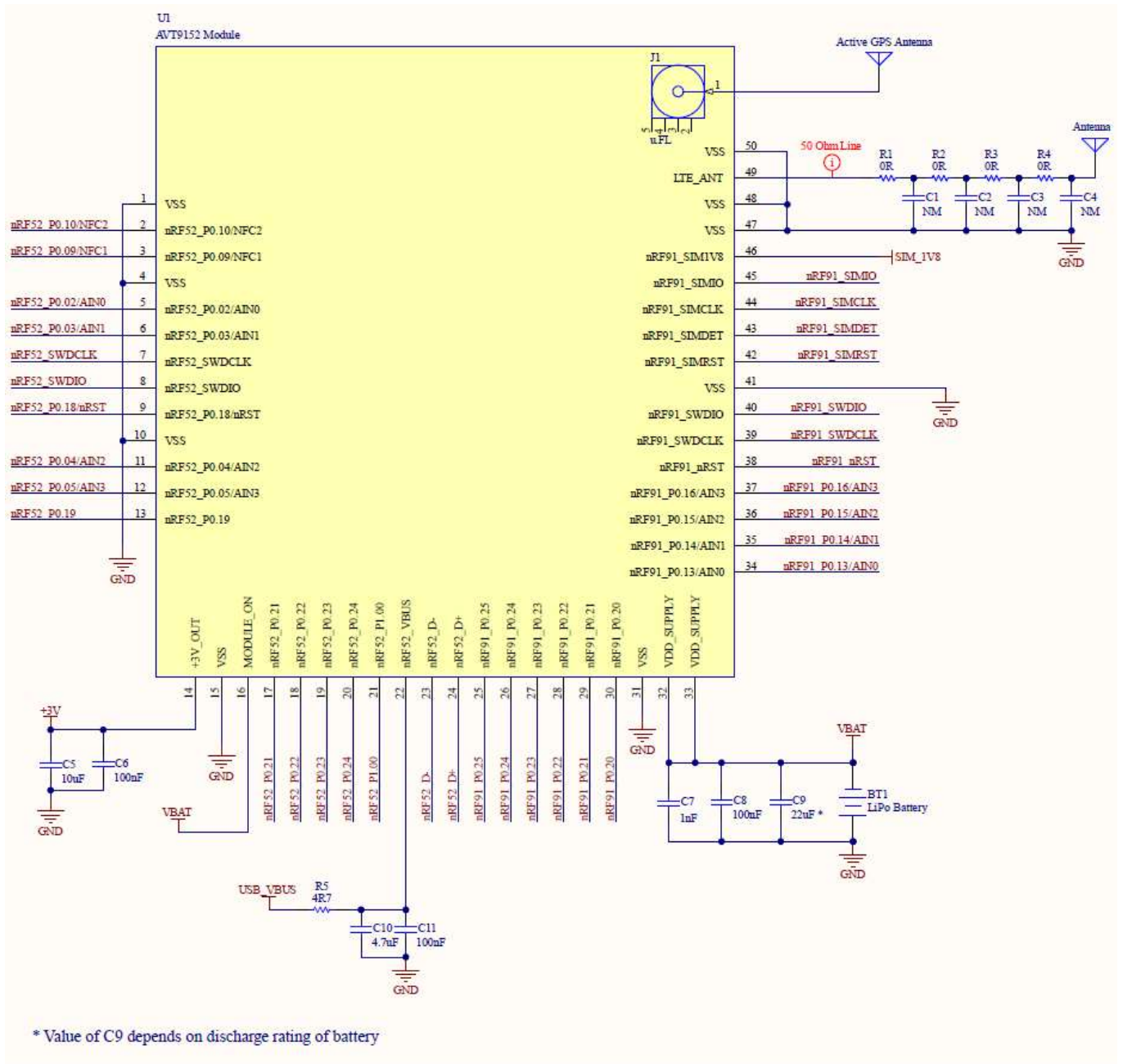

Figure 12: Recommended Matching Network for 50Ω LTE Antenna

- nRF91\_nRST is internally pulled up to 2.2V. Do not attach external pull-up resistor, or drive the pin high with voltage higher than 2.2V.
- There are two 100uF ceramic capacitors on VDD\_SUPPLY line inside the module, to cater for current surge during LTE modem operation. User can add more capacitors to VDD\_SUPPLY if Host battery has limited discharge current rating.
- Ensure adequate decoupling capacitors on power lines to avoid EMC issue.

9. Reference Circuitry



\* Value of C9 depends on discharge rating of battery

Figure 13: Reference Schematic

### 10. Application Example – Tracking Device

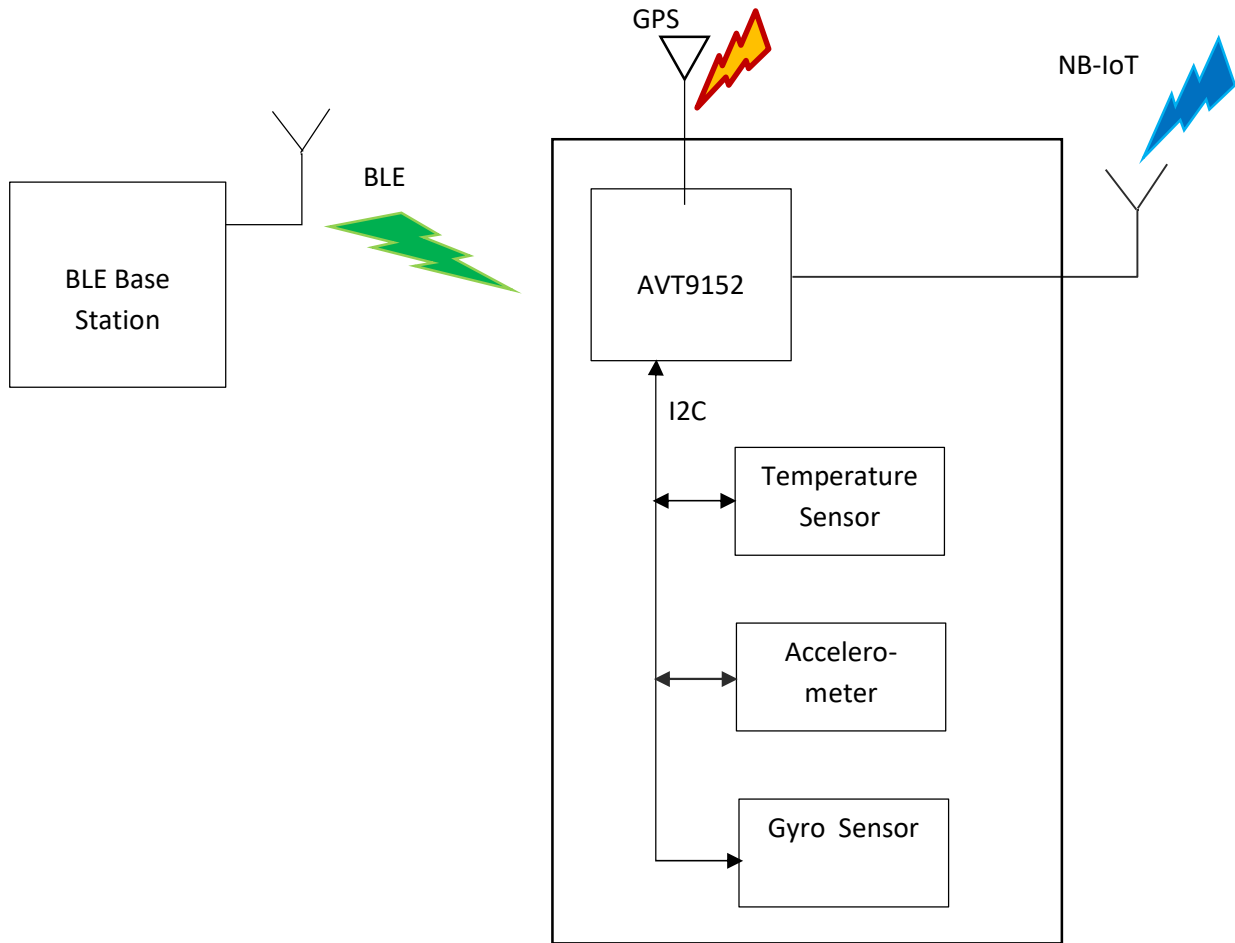

Figure 14: Example of Tracking Device using AVT9152

## 11. Regulatory Information

The product had been certified to conform with following Standards:  
FCC, CE, ACMA and BQB.

For certifications of LTE modem (nRF9160) with PTCRB, GCF, various local authorities and telecom operators, please refer to Nordic semiconductor's website.

### 11.1. FCC

#### **FCC ID: 2AW4N00AVT9152MOD00**

#### **Contains FCC ID: 2ANPO00NRF9160**

To reuse nRF9160's FCC ID (2ANPO00NRF9160), please observe maximum antenna gain requirement in nRF9160's TCB report.

#### **FCC Interference Statement**

This product has been tested and found to comply with the limits for a Class B digital device, pursuant to Part 15 of the FCC Rules. These limits are designed to provide reasonable protection against harmful interference in a residential installation.

This product generates, uses, and can radiate radio frequency energy and, if not installed and used in accordance with the instructions, may cause harmful interference to radio communications. However, there is no guarantee that interference will not occur in a particular installation.

If this product does cause harmful interference to radio or television reception, which can be determined by turning the equipment off and on, the user is encouraged to try to correct the interference by one or more of the following measures:

- Reorient or relocate the receiving antenna.
- Increase the separation between the equipment and receiver.
- Connect the equipment into an outlet on a circuit different from that to which the receiver is connected.
- Consult the dealer or an experienced radio/TV technician for help.

FCC Caution: Any changes or modifications not expressly approved by the party responsible for compliance could void the user's authority to operate this equipment.

This device complies with Part 15 of the FCC Rules. Operation is subject to the following two conditions:

(1) This device may not cause harmful interference, and (2) this device must accept any interference received, including interference that may cause undesired operation.

This device and its antenna(s) must not be co-located or operating in conjunction with any other antenna or transmitter.

#### **FCC Radiation Exposure Statement:**

This equipment complies with FCC radiation exposure limits set forth for an uncontrolled environment. This equipment should be installed and operated with minimum distance 20cm between the radiator & your body.

**DATASHEET****This module is intended for OEM integrators under the following conditions:**

1. This module is certified pursuant to Part 15 rules section(15.247).
2. This module is limited to host model number: AES-CELLIOT-AVT9152KIT, Brand: Avnet.
3. This module has been approved to operate with the antenna types listed below, with the maximum permissible gain indicated.

Frequency Band	Antenna Type	Gain(dBi)
2400-2483.5MHz	SMD Antenna	1.5

## 4. Label and compliance information

**Label of the end product:**

The host product must be labeled in a visible area with the following "Contains FCC ID: 2AW4N00AVT9152MOD00 ", "Contains FCC ID: 2ANPO00NRF9160".

The end product shall bear the following 15.19 statement: This device complies with part 15 of the FCC Rules. Operation is subject to the following two conditions: (1) This device may not cause harmful interference, and (2) this device must accept any interference received, including interference that may cause undesired operation.

## 5. Information on test modes and additional testing requirements

Separate approval is required for all other operating configurations, including portable configurations with respect to Part 2.1093 and different antenna configurations.

The information on how to configure test modes for host product evaluation for different operational conditions for a stand-alone modular transmitter in a host, versus with multiple, simultaneously transmitting modules or other transmitters in a host can be found at KDB Publication 996369 D04.

## 6. Additional testing, Part 15 Subpart B disclaimer

Appropriate measurements (e.g. 15B compliance) and if applicable additional equipment authorizations (e.g. SDoC) of the host product to be addressed by the integrator/manufacture.

This module is only FCC authorized for the specific rule part 15.247 listed on the grant, and the host product manufacturer is responsible for compliance to any other FCC rules that apply to the host product as being Part 15 Subpart B compliant.

## 7. The user manual of the end product should include:

Any changes or modifications not expressly approved by the party responsible for compliance could void the user's authority to operate this equipment.

The antenna(s) used for this transmitter must be installed to provide a separation distance of at least 20 cm from all persons.

This device complies with part 15 of the FCC Rules. Operation is subject to the following two conditions: (1) This device may not cause harmful interference, and (2) this device must accept any interference received, including interference that may cause undesired operation.

This device and its antenna(s) must not be co-located or operating in conjunction with any other antenna or transmitter.



11.2. BQB

**Declaration ID: D051401**

## 12. Order Information

### 12.1. Order Information

AES-CELLIOT-AVT9152MOD

### 12.2. Module Label

Below is the label on AVT9152 module.

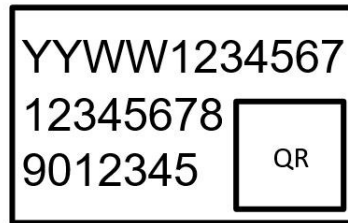

*Figure 155: AVT9152 Label*

The format of the label is as below:

“YYWW1234567” is the serial number. “YY” are the two last digits of the manufacturing year and “WW” identifies the manufacturing week of the year.

“123456789012345” is the IMEI number of nRF9160 device in AVT9152 module.

## 13. Storage, Packaging and Manufacturing

### 13.1. Storage

AVT9152 module is stored in a vacuum-sealed bag. MSL of the module is rated at 3. Storage requirements are as shown below.

1. Calculated shelf life in the vacuum-sealed bag: 12 months at <math><40^{\circ}\text{C}</math> and 90%RH.
2. After the vacuum-sealed bag is opened, devices that will be subjected to reflow solder or other high temperature processes must be:
  - Mounted within 168 hours at factory environment of  $\leq 30^{\circ}\text{C}$  and 60%RH, or
  - Stored as per J-STD-033.
3. Devices require baking before mounting, if any circumstance below occurs.
  - When ambient temperature is  $23^{\circ}\text{C} \pm 5^{\circ}\text{C}$  and humidity indication card shows that humidity is  $>10\%$  when opening the vacuum-sealed bag.
  - Device mounting cannot be finished within 168 hours at factory conditions of  $\leq 30^{\circ}\text{C}$  and 60%RH, or devices are not stored as per J-STD-033.
4. If baking is required, refer to IPC/JEDEC J-STD-033 for bake procedure.

### 13.2. Packaging

AVT9152 module is packaged in reel of 300pcs. Diameter of reel is 330mm.

There is 4 reels/CTN or 1200pcs/CTN.

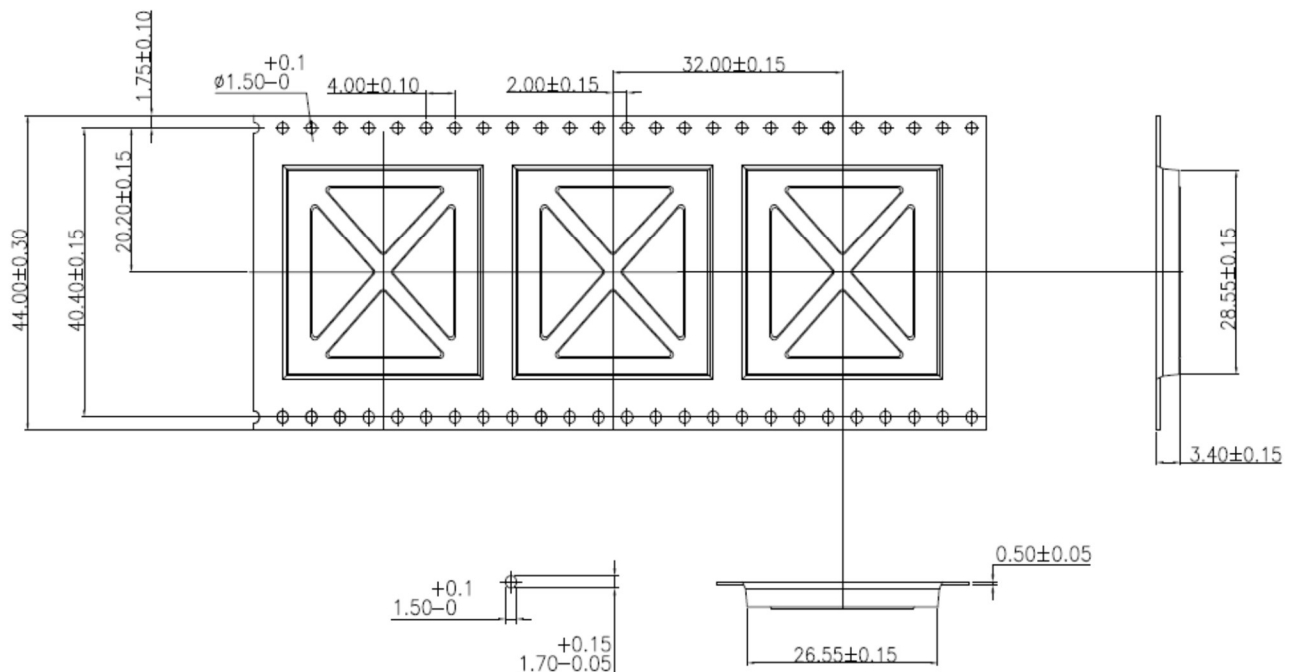

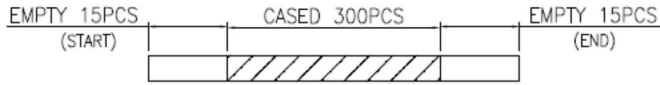

Figure 166: Tape Dimensions (Unit: mm)

### 13.3. Manufacturing

Recommended reflow profile is as shown below.

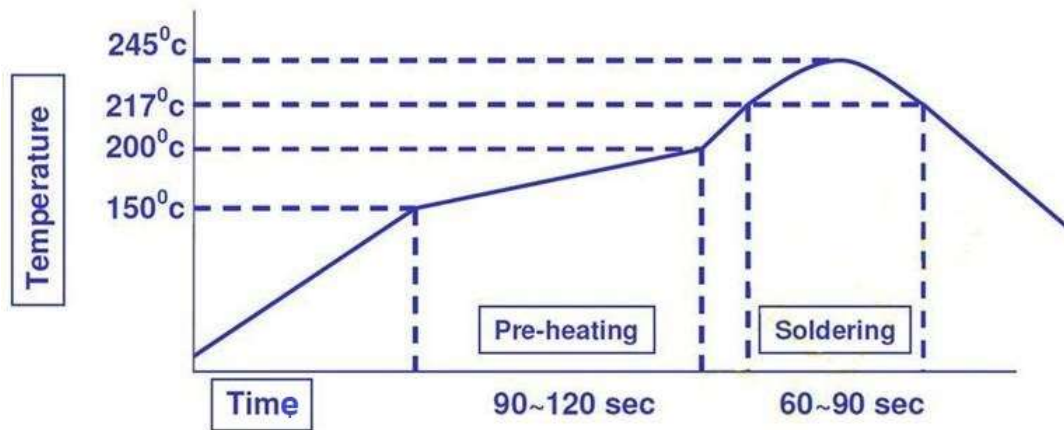

Figure 177: Reflow Profile

## 14. Legal Notice

### Limitations

This product is not intended for use in safety-critical applications (such as life support or automotive) where a failure of the Avnet product could be expected to cause severe personal injury or death. Please refer to the final section of this document for additional restrictions to Avnet's legal liability

### Avnet Module License and Product Warranty

THIS AVNET MODULE (OR "PRODUCT") AND ANY SUPPORTING DOCUMENTATION IS SUBJECT TO THIS LICENSE AGREEMENT. USE OF THIS PRODUCT OR DOCUMENTATION SIGNIFIES ACCEPTANCE OF THE TERMS AND CONDITIONS OF THIS LICENSE.

THE TERMS OF THIS LICENSE AGREEMENT ARE IN ADDITION TO THE AVNET CUSTOMER TERMS AND CONDITIONS, WHICH CAN BE VIEWED AT [www.em.avnet.com](http://www.em.avnet.com). THE TERMS OF THIS LICENSE AGREEMENT WILL CONTROL IN THE EVENT OF A CONFLICT

**1. Limited License.** Avnet grants You, the Customer, ("You" "Your" or "Customer") a limited, non-exclusive, non-transferable, license to: (a) use the Product for Your own internal testing, evaluation and design efforts at a single Customer site; (c) make, use and sell the Product in a single production unit. No other rights are granted and Avnet and any other Product licensor reserves all rights not specifically granted in this License Agreement. Except as expressly permitted in this License, neither the Module, Documentation, nor any portion may be reverse engineered, disassembled, decompiled, sold, donated, shared, leased, assigned, sublicensed or otherwise transferred by Customer. The term of this License is in effect until terminated. Customer may terminate this license at any time by destroying the Product and all copies of the Product Documentation.

**2. Changes.** Avnet may make changes to the Product or Product Documentation at any time without notice. Avnet makes no commitment to update or upgrade the Product or Product Documentation and Avnet reserves the right to discontinue the Product or Product Documentation at any time without notice.

**3. Product Documentation.** Product Documentation is provided by Avnet on an "AS-IS" basis and does not form a part of the properties of the Product. All Product Documentation is subject to change without notice. Avnet makes no representation as to the accuracy or completeness of the Product Documentation, and DISCLAIMS ALL REPRESENTATIONS, WARRANTIES AND LIABILITIES UNDER ANY THEORY WITH RESPECT TO PRODUCT INFORMATION.

**4. Limited Product Warranty.** AVNET WARRANTS THAT AT THE TIME OF DELIVERY, THE PRODUCTS SHALL MEET THE SPECIFICATIONS STATED IN AVNET DOCUMENTATION FOR SIXTY (60) DAYS FROM DELIVERY OF PRODUCTS. IF THE CUSTOMER CAN PROVIDE PROOF THAT THE QUALIFIED AVNET PRODUCT WAS PURCHASED FOR THE PURPOSE OF AND DEPLOYED AS A COMPONENT IN THE CUSTOMER'S COMMERCIALY AVAILABLE PRODUCT THE WARRANTY WILL BE EXTENDED TO TWELVE (12) MONTHS FROM THE DATE OF PURCHASE. TO THE EXTENT PERMITTED BY LAW, AVNET MAKES NO OTHER WARRANTY, EXPRESS OR IMPLIED, SUCH AS WARRANTY OF MERCHANTABILITY, FITNESS FOR PURPOSE OR NON-INFRINGEMENT. YOUR SOLE AND EXCLUSIVE REMEDY FOR BREACH OF AVNET'S WARRANTY IS, AT AVNET'S CHOICE: (I) REPAIR THE PRODUCTS; (ii) REPLACE THE PRODUCTS AT NO COST TO YOU; OR (iii) REFUND YOU THE PURCHASE PRICE OF PRODUCTS.

**5. LIMITATIONS OF LIABILITY.** CUSTOMER SHALL NOT BE ENTITLED TO AND AVNET WILL NOT BE LIABLE FOR ANY INDIRECT, SPECIAL, INCIDENTAL OR CONSEQUENTIAL DAMAGES OF ANY KIND OR NATURE, INCLUDING, WITHOUT LIMITATION, BUSINESS INTERRUPTION COSTS, LOSS OF PROFIT OR REVENUE, LOSS OF DATA, PROMOTIONAL OR MANUFACTURING EXPENSES, OVERHEAD, COSTS OR EXPENSES ASSOCIATED WITH WARRANTY OR INTELLECTUAL

**DATASHEET**

PROPERTY INFRINGEMENT CLAIMS, INJURY TO REPUTATION OR LOSS OF CUSTOMERS, EVEN IF AVNET HAS BEEN ADVISED OF THE POSSIBILITY OF SUCH DAMAGES. THE PRODUCTS AND DOCUMENTATION ARE NOT DESIGNED, AUTHORIZED OR WARRANTED TO BE SUITABLE FOR USE IN MEDICAL, MILITARY, AIR CRAFT, SPACE

OR LIFE SUPPORT EQUIPMENT NOR IN APPLICATIONS WHERE FAILURE OR MALFUNCTION OF THE PRODUCTS CAN REASONABLY BE EXPECTED TO RESULT IN A PERSONAL INJURY, DEATH OR SEVERE PROPERTY OR ENVIRONMENTAL DAMAGE. INCLUSION OR USE OF PRODUCTS IN SUCH EQUIPMENT OR APPLICATIONS, WITHOUT PRIOR AUTHORIZATION IN WRITING OF AVNET, IS NOT PERMITTED AND IS AT CUSTOMER'S OWN RISK. CUSTOMER AGREES TO FULLY INDEMNIFY AVNET FOR ANY DAMAGES RESULTING FROM SUCH INCLUSION OR USE.

**6. LIMITATION OF DAMAGES.** CUSTOMER'S RECOVERY FROM AVNET FOR ANY CLAIM SHALL NOT EXCEED CUSTOMER'S PURCHASE PRICE FOR THE PRODUCT GIVING RISE TO SUCH CLAIM IRRESPECTIVE OF THE NATURE OF THE CLAIM, WHETHER IN CONTRACT, TORT, WARRANTY, OR OTHERWISE.

**7. INDEMNIFICATION.** AVNET SHALL NOT BE LIABLE FOR AND CUSTOMER SHALL INDEMNIFY, DEFEND AND HOLD AVNET HARMLESS FROM ANY CLAIMS BASED ON AVNET'S COMPLIANCE WITH CUSTOMER'S DESIGNS, SPECIFICATIONS OR INSTRUCTIONS, OR MODIFICATION OF ANY PRODUCT BY PARTIES OTHER THAN AVNET, OR USE IN COMBINATION WITH OTHER PRODUCTS.

**8. U.S. Government Restricted Rights.** The Product and Product Documentation are provided with "RESTRICTED RIGHTS." If the Product and Product Documentation and related technology or documentation are provided to or made available to the United States Government, any use, duplication, or disclosure by the United States Government is subject to restrictions applicable to proprietary commercial computer software as set forth in FAR 52.227-14 and DFAR 252.227-7013, et seq., its successor and other applicable laws and regulations. Use of the Product by the United States Government constitutes acknowledgment of the proprietary rights of Avnet and any third parties. No other governments are authorized to use the Product without written agreement of Avnet and applicable third parties.

**9. Ownership.** Licensee acknowledges and agrees that Avnet or Avnet's licensors are the sole and exclusive owner of all Intellectual Property Rights in the Licensed Materials, and Licensee shall acquire no right, title, or interest in the Licensed Materials, other than any rights expressly granted in this Agreement.

**10. Intellectual Property.** All trademarks, service marks, logos, slogans, domain names and trade names (collectively "Marks") are the properties of their respective owners. Avnet disclaims any proprietary interest in Marks other than its own. Avnet and AV design logos are registered trademarks and service marks of Avnet, Inc. Avnet's Marks may be used only with the prior written permission of Avnet, Inc.

**11. General.** The terms and conditions set forth in the License Agreement or at [www.em.avnet.com](http://www.em.avnet.com) will apply notwithstanding any conflicting, contrary or additional terms and conditions in any purchase order, sales acknowledgement confirmation or other document. If there is any conflict, the terms of this License Agreement will control. This License may not be assigned by Customer, by operation of law, merger or otherwise, without the prior written consent of Avnet and any attempted or purported assignment shall be void. Licensee understands that portions of the Licensed Materials may have been licensed to Avnet from third parties and that such third parties are intended beneficiaries of the provisions of this Agreement. In the event any of the provisions of this Agreement are for any reason determined to be void or unenforceable, the remaining provisions will remain in full effect. This constitutes the entire agreement between the parties with respect to the use of this Product, and supersedes all prior or contemporaneous understandings or agreements, written or oral, regarding such subject matter. No waiver or modification is

**DATASHEET**



effective unless agreed to in writing and signed by authorized representatives of both parties. The obligations, rights, terms and conditions shall be binding on the parties and their respective successors and assigns. The License Agreement is governed by and construed in accordance with the laws of the State of Arizona excluding any law or principle, which would apply the law of any other jurisdiction. The United Nations Convention for the International Sale of Goods shall not apply.

**Copyright © 2020, Avnet, Inc.** All rights reserved. Published by Avnet Electronics Marketing, a group of Avnet, Inc. Avnet, Inc. disclaims any proprietary interest or right in any trademarks, service marks, logos, domain names, company names, brands, product names, or other form of intellectual property other than its own. AVNET and the AV logos are registered trademarks of Avnet, Inc.

## 15. Contact Information

For further details, contact your local Avnet representative or e-mail us at:

Region	Organization	Email	Address & Phone
North America	Avnet Americas	eval.kits@avnet.com	Avnet Americas 2211 South 47th Street Phoenix, AZ 85034 USA  Phone: 1-800-585-1602
Europe	Avnet Silica	marketing@silica.com	Avnet Silica Gruber Str. 60c 85586 Poing, Germany  Phone: +49-8121-77702
Asia	Avnet Asia	asia-ads-contact@avnet.com	Avnet Asia Pte Ltd 151 Lorong Chuan #05-03 New Tech Park Singapore 556741  Phone: +65-6580-6000



## 16. Revision History

<b>Date</b>	<b>Version</b>	<b>Description</b>
December 2020	1.0	First Release