



Fast DC EV Charging: Common Topologies and Power Devices Used in the System

Fast DC EV Charging: Common Topologies and Power Devices Used in the System

The role of DC Fast charging (DCFC) is clear in removing barriers to EV adoption. The need for shorter charging times has resulted in higher power EV fast charging approaches 400 kW entering the market. In this paper, we will discuss an overview of typical power converter topologies and power devices for the AC–DC and the DC–DC used in fast DC EV charging.

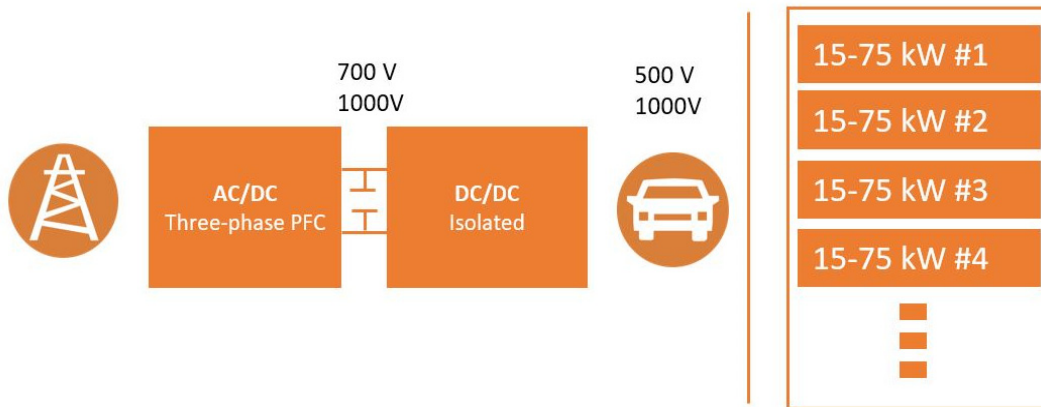

Figure 1. Diagram of Fast DC EV Charger Architecture

Active Rectification Three–Phase PFC Boost Topologies

Three–phase Power Factor Correction (PFC) systems (or also call Active Rectification or Active Front–End systems) are becoming of great interest, experiencing a sharp increase in demand in recent years. Three–phase Power Factor Correction (PFC) topologies are key for efficiently powering the fast DC charging. By incorporating [Silicon Carbide \(SiC\) power semiconductors](#) to your three–phase PFC topologies, one can address the normally conflicting challenge of reducing power losses and increase power density.

The front–end three–phase PFC boost stage might be implemented in multiple topologies, and several ones might fulfill the same electrical requirements. Figure 2 illustrates common PFC architectures in fast DC EV charging applications. One of the first distinctions to be made among them is bi–directionality. The T–Neutral Point Clamp (T–NPC) and I–NPC topologies are suitable for bi–directional operation by replacing some of the diodes with switches. The 6–switch architecture is bi–directional per se.

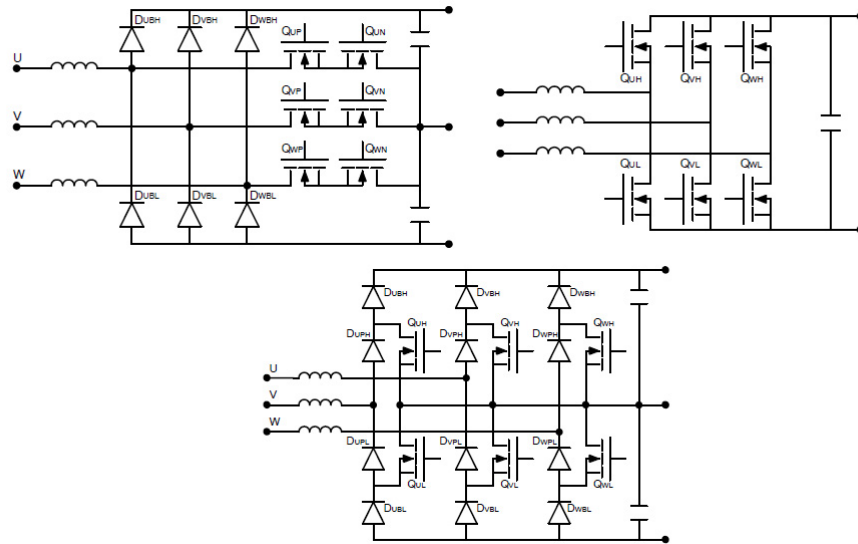

Figure 2. Typical Three-Phase Power Factor Correction (PFC) Boost Topologies for Fast DC EV Charging. T-NPC (top left), 6-switch (top right) and I-NPC (bottom)

An additional important factor that will influence the design and the voltage rating of the power devices is the number of levels in the architecture. The 6-switch topology is a 2-level architecture, normally implemented with 900 V or 1200 V switches for fast DC EV chargers. Here [SiC MOSFET modules with low R_{DSon} \(6 – 40 mΩ\)](#) are a preferred solution, especially for higher power ranges above 15 kW per block.

Such integrations exhibit a superior power performance than discrete solutions, increasing efficiency, simplifying the design, reducing overall system size and maximizing reliability. The T-Neutral Point Clamp (T-NPC) is a 3-level topology that uses 1200 V rectifiers (replaced with switches in a bi-directional format), with 650 V switches back-to-back on the neutral path. The I-NPC is a 3-level architecture and might be fully implemented with 650 V switches. The [650 V SiC MOSFETs](#) or [IGBTs with co-pack diode](#) represent excellent alternative solutions for these 3-level topologies.

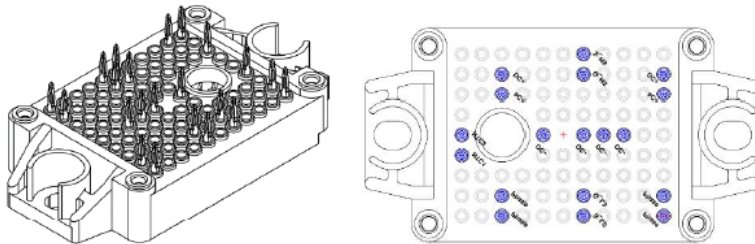

Figure 3. F1-2 PACK SiC MOSFET Module Half-Bridge. 1200 V, 10 mΩ

DC–DC Topologies

When looking into the DC–DC conversion stages, three main isolated topologies are employed: the full–bridge LLC resonant converter, the full–bridge phase–shift Dual Active Bridge (DAB) Zero Voltage Transition (ZVT) converter and the full–bridge phase–shift ZVT converter (Figures 4, 5 and 6).

Full–Bridge LLC Resonant

The LLC converter enables Zero Voltage Switching (ZVS) on the primary side and also – at resonant frequency and below – Zero Current Switching (ZCS) on the secondary side, resulting into a very high peak efficiency around the resonant frequency. As a pure frequency modulated (FM) system, the LLC efficiency degrades when the system operating point shifts away from the resonant frequency, which might be the case when wide output voltage operation is required. Yet, advanced hybrid modulation schemes enable today pulse with modulation (PWM) in combination with FM, limiting the max frequency runaway and the high losses. Still, this hybrid implementations add complexity to the already sometimes cumbersome LLC control algorithms. Furthermore, current sharing and synchronization of LLCs converters in parallel is not trivial. In general, when possible to be operated around relatively tight voltage ranges, and/or when the development skills to implement advance control strategies that combine FM and PWM are available, the LLC is a design difficult to beat. Not only could it deliver the highest efficiency, but be a very well–rounded solution from all perspectives. The LLC can be implemented in a bi–directional format as a CLLC, which is another sophisticated topology.

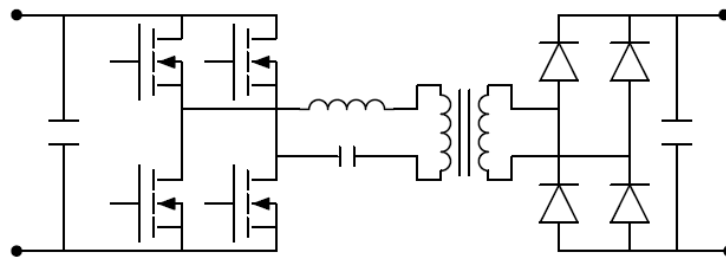

Figure 4. Full–Bridge LLC Converter

Full–bridge phase–shift Dual Active Bridge (DAB) Zero Voltage Transition (ZVT) Phase–shifted full–bridge DAB with secondary synchronous rectification topologies are also very typical. These operate with PWM and in general require a simpler control than LLC converters. The DAB can be considered an evolution of the conventional full–bridge phase–shift ZVT converter, but with the leakage inductor on the primary side, which simplifies the cumbersome secondary side rectification and reduces the necessary breakdown voltage rating on secondary switches or diodes. With ZVT achieved, these converters can provide stable high efficiency across a wide output voltage range. This is a convenient factor for chargers supporting 800 V and 400 V battery voltage levels. The PWM operation of the DAB brings to

benefits. Firstly, it tends to keep the Electromagnetic Interference (EMI) spectrum of the converter tighter than in FM systems. Furthermore, the behavior of the system at low loads is easier to address with a fixed switching frequency. Implemented with synchronous rectification, the DAB is a bi-directional native topology and is one of the most versatile alternatives and suitable solution for fast DC EV charging.

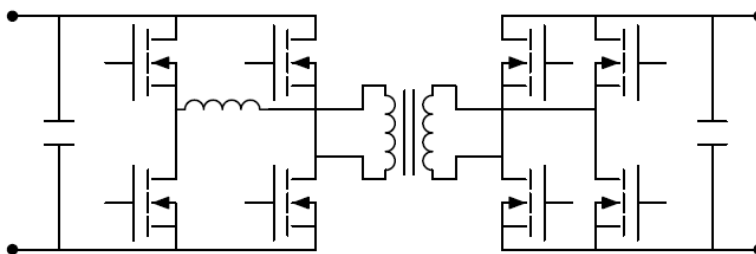

Figure 5. Full-Bridge Phase-Shift DAB ZVT Converters

Full-Bridge Phase-Shift Zero Voltage Transition (ZVT)

For uni-directional operation, the conventional full-bridge phase-shift ZVT (Figure 6) remains still a utilized option with diminishing penetration. This topology operates similarly as the DAB, but the inductor sitting in the secondary side introduces significant difference in the rectification behavior. The inductor sets high reverse voltages on the diodes, which will be proportional and inversely proportional to the duty cycle, and therefore, depending on the operating conditions, reverse voltages on the diode in excess of two and three times the output voltage might arise. Such a situation might be challenging to address in high output voltage systems (like in EV chargers) and typically multiple secondary windings (featuring a lower output voltage) are connected in series. Such a configuration is not so convenient, especially if for given power and voltage ratings a different topology with a single output would deliver the same or better performance.

[SiC modules](#) represent a very suitable and common solution for the full-bridge in the DC-DC power conversion stages mentioned above, starting at 15 kW. The higher frequencies enabled help shrink the transformer and inductor sizes and therefore the complete solution form factor.

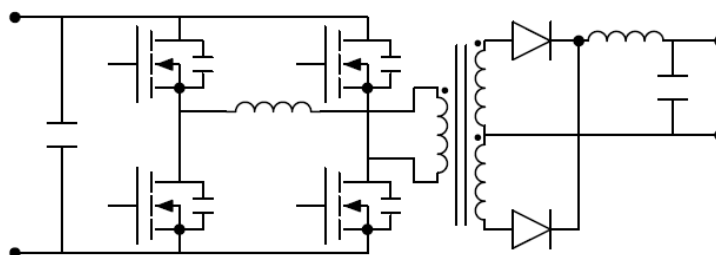

Figure 6. Full-Bridge Phase-Shift ZVT Converters

Topology Variations

Multiple variants for the discussed topologies exist, bringing additional advantages and compromises. Figure 7 shows a common alternative of the full bridge LLC converter used for fast DC EV charging. In the phase-shift, the switches are under half of the input voltage and 600 V and 650 V break-down voltage devices are used. [650 V SiC MOSFETs](#), [650 V SuperFET3 Fast Recovery \(FR\) MOSFETs](#) and [650 V FS4 IGBTs](#) will help address different system requirements. Similarly, diodes and rectifiers for the primary side need blocking voltage ratings of 650 V. This 3-level architectures allow for a unipolar switching, which contributes in reducing the peak current and current ripples, which will results into a smaller transformer. One of the main downsides of this topology is the additional complexity level that the control algorithm requires, compared to 2-level version with fewer power switches. The DAB as well as the can easily be connected in parallel or stacked both on the primary side and on the secondary side to best suit the current and voltage needs of the fast DC EV chargers.

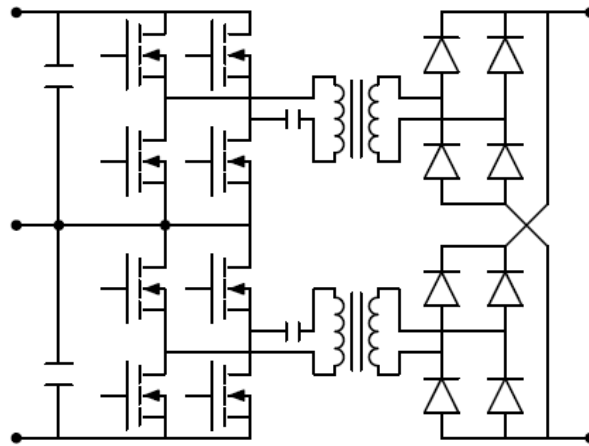

Figure 7. 3-Level Full Bridge LLC. This Variation is Stacked on the Primary Side

(only a half of the input voltage is applied to each transformer) and connected in parallel on the secondary side.

Secondary Side Rectification

Regarding the secondary rectification stage multiple solutions are possible as see in Figure 6 and all could be used with different topologies. For 400 V and 800 V battery levels and full-bridge rectification, the [650 V and 1200 V SiC Schottky diodes](#) typically bring a unique performance-to-cost solution. Due to their zero reverse recovery characteristic, these devices significantly enhance rectification performance and efficiency compared to silicon-based alternatives, drastically reducing losses and the complexity of the rectification stage. Silicon-based diodes such as the HyperFast, UltraFast and Stealth could serve as an alternative in very cost constraint projects at the expenses of performance and complexity. Solutions with center-tap rectification (Figure 6) are not convenient for high voltage output

rectification stages. Unlike in full-bridge rectification, where diodes withstand a reverse voltage equal to the output voltage, in center-tapped configurations the diodes withstand two times this value. Regular full-bridge phase-shift converters (inductor at the secondary side), as explained, require higher breakdown voltage diodes in both rectification methods (full-bridge or center-tap rectification). To overcome the need for 1200 V or 1700 V rated diodes in conventional full-bridge phase-shift converters, several outputs would be connected in series.

onsemi, **Onsemi**, and other names, marks, and brands are registered and/or common law trademarks of Semiconductor Components Industries, LLC dba "**onsemi**" or its affiliates and/or subsidiaries in the United States and/or other countries. **onsemi** owns the rights to a number of patents, trademarks, copyrights, trade secrets, and other intellectual property. A listing of **onsemi**'s product/patent coverage may be accessed at www.onsemi.com/site/pdf/Patent-Marking.pdf. **onsemi** reserves the right to make changes at any time to any products or information herein, without notice. The information herein is provided "as-is" and **onsemi** makes no warranty, representation or guarantee regarding the accuracy of the information, product features, availability, functionality, or suitability of its products for any particular purpose, nor does **onsemi** assume any liability arising out of the application or use of any product or circuit, and specifically disclaims any and all liability, including without limitation special, consequential or incidental damages. Buyer is responsible for its products and applications using **onsemi** products, including compliance with all laws, regulations and safety requirements or standards, regardless of any support or applications information provided by **onsemi**. "Typical" parameters which may be provided in **onsemi** data sheets and/or specifications can and do vary in different applications and actual performance may vary over time. All operating parameters, including "Typicals" must be validated for each customer application by customer's technical experts. **onsemi** does not convey any license under any of its intellectual property rights nor the rights of others. **onsemi** products are not designed, intended, or authorized for use as a critical component in life support systems or any FDA Class 3 medical devices or medical devices with a same or similar classification in a foreign jurisdiction or any devices intended for implantation in the human body. Should Buyer purchase or use **onsemi** products for any such unintended or unauthorized application, Buyer shall indemnify and hold **onsemi** and its officers, employees, subsidiaries, affiliates, and distributors harmless against all claims, costs, damages, and expenses, and reasonable attorney fees arising out of, directly or indirectly, any claim of personal injury or death associated with such unintended or unauthorized use, even if such claim alleges that **onsemi** was negligent regarding the design or manufacture of the part. **onsemi** is an Equal Opportunity/Affirmative Action Employer. This literature is subject to all applicable copyright laws and is not for resale in any manner.

PUBLICATION ORDERING INFORMATION

LITERATURE FULFILLMENT:

Email Requests to: orderlit@onsemi.com

onsemi Website: www.onsemi.com

TECHNICAL SUPPORT

North American Technical Support:

Voice Mail: 1 800-282-9855 Toll Free USA/Canada

Phone: 011 421 33 790 2910

Europe, Middle East and Africa Technical Support:

Phone: 00421 33 790 2910

For additional information, please contact your local Sales Representative