



## Lowering the Cost of Powering your Horticultural Lighting Systems

At Artesyn Embedded Technologies, our focus when creating power supplies for horticultural lighting is to minimize your power consumption, installation expense and the cost of cooling your facilities.

We offer a range of high power options (600 watt to megawatt), scaling from single conduction/IP-rated power supplies up to large distributed external systems ideal for vertical farms and large warehouse grow centers.

Our power supplies for individual luminaires and lower power applications (ranging from 300 W to 3000 W) are designed to provide full power in compact, high density packaging that weighs less than other commercially available products.

With large farms, the use of individual luminaires is not efficient. The added complexity of individual control systems on each luminaire and the additional cabling required adds to your installation costs. What's more, the additional thermal management needed (air conditioning) as a result of the collective conversion/heat losses from the drivers adds to your energy costs.

Using a large centralized current source outside the environmentally controlled growth areas and distributing power directly to all the luminaires can help eliminate the need for individual drivers and the associated costs. By offering single conduction and IP rated solutions up to large distributed external systems, Artesyn can help scale power for various power distribution architectures in practically any installation.

**Cost  
Effective**

**Reliable**

**Highly  
Efficient**

**Scalable**

**Flexible**

**Easily  
Controlled**

The use of LED technology in horticultural lighting systems is playing a fundamental role in cutting-edge farming and growing practices that are increasingly seen as a potential way of addressing production challenges for food, pharmaceutical ingredients, plants and flowers.

LED-based horticultural lighting is one of the largest and fastest growing markets.

Lighting for horticulture is quite distinct from other lighting applications. Light, in the wavelengths useful for horticulture, is called photo-synthetically active radiation (PAR) and falls within the 400-700nm range.

Photosynthetic Photon Flux, or PPF, measures the total amount of PAR photons generated by a luminaire. A higher PPF means the lighting system is more efficient at creating PAR.

As researchers continue to establish the impact of specific wavelengths of light on different plants and stages of growth, broad-spectrum sources such as high pressure sodium (HPS) lamps, popularly used in greenhouses, are being outperformed by LED lights due to their flexibility in producing different PAR wavelengths.

Other compelling benefits of LED lights for horticulture include:

- Spectral output control: LED lights offer greater control over the light output across different wavelengths, so growers can more closely match spectra to the needs of their plants, plus their luminosity can be adjusted to manage production depending on plant species and growth stage.
- More precise targeting: The availability of smaller LED lights improves control over where the light goes, increasing efficiency and reducing energy consumption.
- Less radiated heat: LED lights operate cooler than traditional HPS bulbs so can be placed closer to plants, resulting in more dense farms. This also lowers water consumption.
- Life cycle savings: LED luminaires typically have a longer lifetime, lower energy consumption and lower maintenance costs than traditional horticultural lighting options

The benefits outlined above combine to make LED lighting the ideal choice for supplemental lighting in greenhouses as well as vertical and indoor farms that depend on artificial light.

## Market Drivers

- **Population growth and limited availability of agricultural land**
- **Ability to grow a steady supply of crops regardless of weather conditions**
- **Increased, higher-quality yield**
- **Government initiatives**
- **Legalization of cannabis for medicinal and recreational purposes**
- **Technical advances in LED technology**

Source: 2018 Horticulture Lighting Report by MarketsandMarkets Research

## Types of Horticultural Lighting

### Top lighting – Greenhouses

- Illumination of the hall and plants from ceiling level
- Retrofitting old HPS, modifying spectral content of light
- Challenges: light concentration on plants, uniformity and constant quality of light spectrum, high amount of power needed

### Top lighting – Vertical farming

- Illumination from top of the plants at close distance
- Challenges: uniform intensity and spectral distribution, plants shading each other, photosynthetic efficiency (PPF/W), heat

### Intra-canopy

- Illumination on the side or in between the plants
- Possible with LEDs (HPS too hot)
- Challenges: uniform PPFD, good color uniformity (if continuous/wide spectrum), spectrum fit to the rest of lighting, light direction

# Innovative Modular and Scalable Power Solutions

By offering single conduction and IP rated solutions up to large distributed external systems, Artesyn can help scale power for various power distribution architectures in practically any installation.

## LCC600 Series



**600 Watts  
Total Power**

- Dimming Control: 0-10V or resistive dimming
- 600 watts from -40 °C to 85 °C baseplate operating temperature
- High efficiency design in a 4" x 9" x 1.57" compact IP65 enclosure under 2 kgs
- Fanless design uses conduction cooling for thermal management – can utilize the same luminaire heatsink for thermal heat transfer
- 90-264 Vac or 180-305 Vac operating input
- Digital control: Constant voltage (default) or constant current mode of operation; programmable constant current limits through I<sup>2</sup>C/PMBus®
- External voltage or resistance dimming capable
- Active share/parallel operation for higher power

## LCM Series



**300 - 3000 Watts  
Total Power**

- Fan-cooled alternative to the LCC600, saving typically 50% of cost
- Digital control – can be set to operate in constant voltage or constant current
- Easily operated in parallel for higher power
- Great for controlled environment applications
- Conformal coating

## iHP Series



**Configurable Intelligent  
High Power System**

- Can drive any LED luminaire
- Customized grow cycle lighting control by setting scheduler (using calendar)
- Dimming Control: 0-5V or 0-10V (output completely off to full max output current)
- Removes driver heat from grow area to save on HVAC costs
- High level of scalability – multiple racks per cabinet can scale up to megawatt levels (in 3 kW increments up to 12 kW in small rack or 24 kW in large rack)
- Highly flexible input (180-528 Vac, single or 3-phase) and outputs (12-1000 Vdc) allows high voltage distribution, saving copper wiring costs
- Intelligent current and voltage source control (local or via Internet) eliminates the need for individual luminaire drivers
- Digitally controlled loop compensation eliminates bothersome flickering throughout entire operating range
- Cloud-based GUI allows simple user customization of lighting profile dashboards

# Power Architecture Examples Using Artesyn Power Supplies

## Conventional Power Distribution with Integrated Luminaire + Driver



Artesyn LCC600



Any 600W LED Luminaire

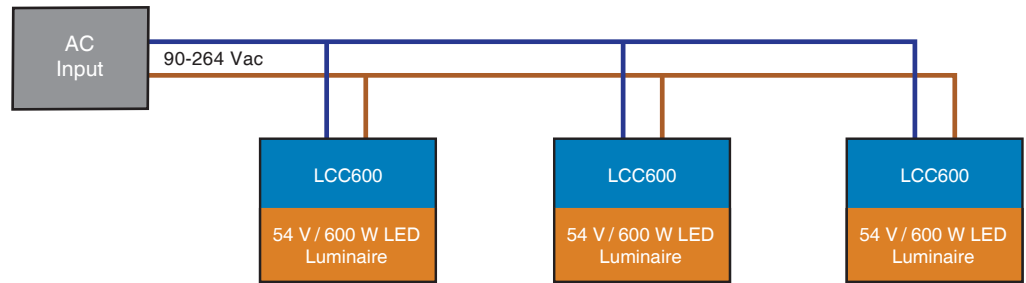

Example shown using Artesyn's LCC600 supply/driver integrated into a 600 W luminaire.

- Easily adaptable for retrofit (can utilize existing power/wiring infrastructure) and new installations
- Dimming Control: 0-10V or resistive Dimming (0-100% output current)
- Heat generated by both luminaire and driver/power supply needs to be considered in energy/cooling calculations

## Centralized Power with Distributed Lighting Using 54 V LED String in Serial Configuration



Artesyn iHP 12KW

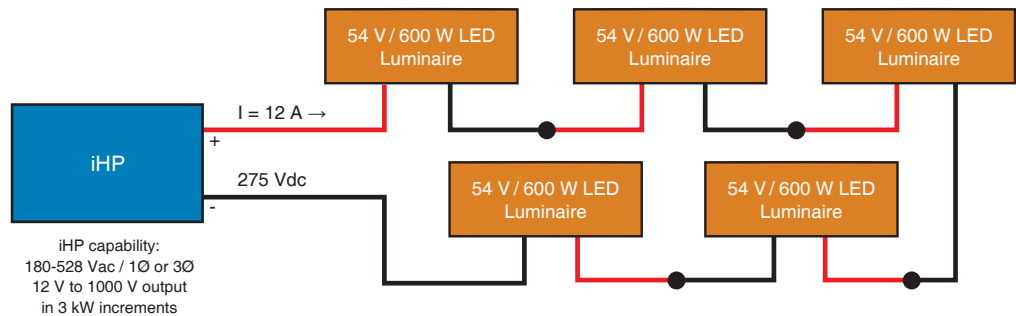

iHP example shown using one (1) 3 kW module set to 275 Vdc, 12 A constant current output.

- Centralized power source and the associated conversion/heat losses can be managed separately outside the environmentally controlled growth space, lowering cooling and energy cost
- Higher voltage distribution can help reduce total installation cost (e.g., reduced wire sizes)
- Faults in serial configuration can shut down all the luminaires connected in the same loop

## Centralized Power with Distributed Lighting Using 250 V LED String in Parallel Configuration

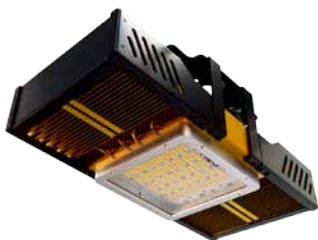

Any 600W LED Luminaire

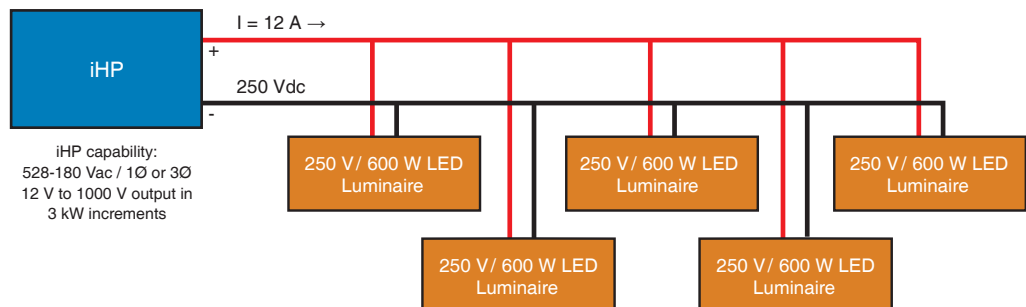

iHP example shown using one (1) 3 kW module set to 250 Vdc, 12 A constant current output.

- 347/600VAC 3-Phase input
- Analog: 0-5V or 0-10V dimming Control (0-100% output current)
- Digital: Cloud-Based Ethernet or LAN control
- Centralized power source and the associated conversion/heat losses can be managed separately outside the environmentally controlled growth space, lowering cooling and energy cost
- Higher voltage distribution can help reduce total installation cost (e.g., reduced wire sizes)
- Faults in parallel configuration will not shut down all luminaires connected on the same power rail

# Architecture of iHP Remote Power System for Horticulture LED Lighting

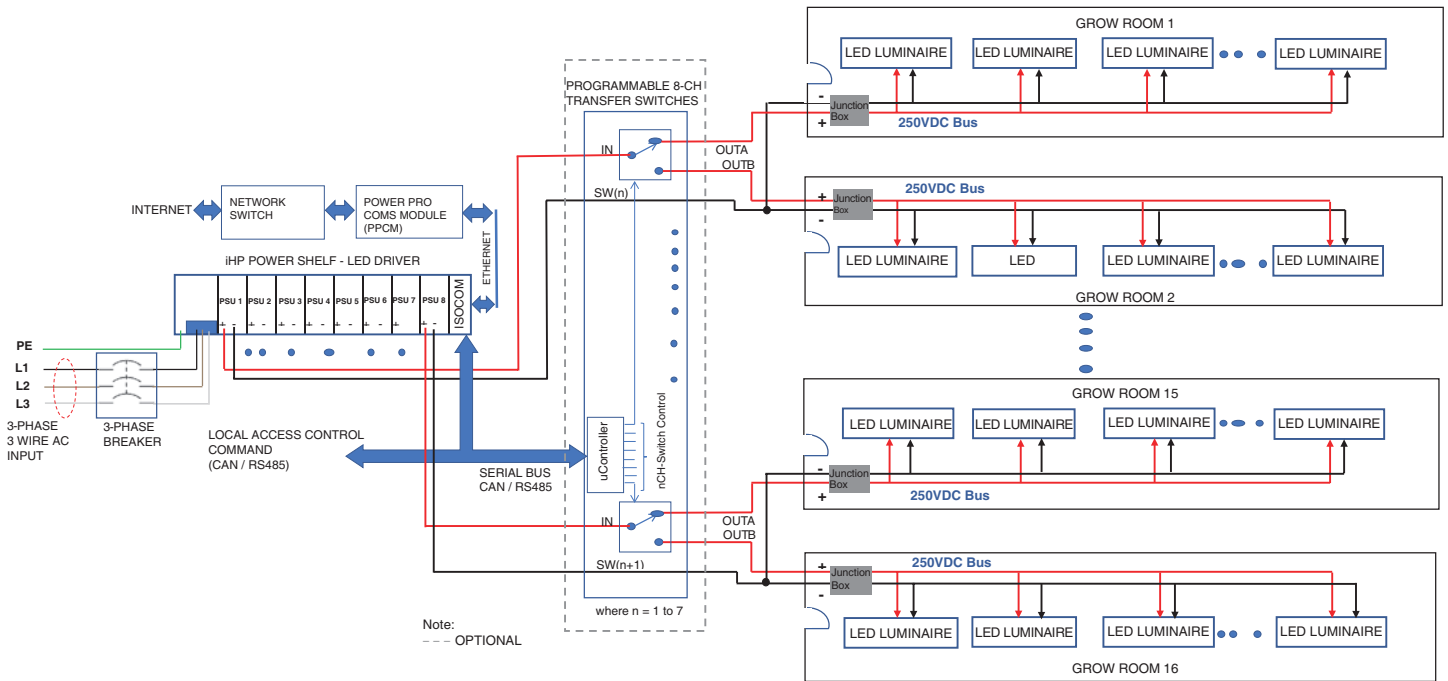

## Application Example: Large warehouse farm requires 126.3 KW of LED luminaries

### SCENARIO 1: STANDARD DIRECT INTEGRATED LIGHTING

AC Hook-up Wiring	Integrated Power, Driver and Thermal Management	Annual A/C Cost Due to Power Dissipation	Relative Installation and First Year Cost
\$21,000	\$54,400	\$9,281	<b>\$80,681</b>
Hook up to 240 integrated lights	Cost of conversion, driver and thermals for 600 W (240 pcs)	Based on 8.8 KW power loss requiring 30,133.5 BTUs/Hr cooling	

### SCENARIO 2: DISTRIBUTED LIGHTING USING LED STRING CONFIGURATION IN 48 V CONFIGURATION

DC Hook-up Wiring	Remote Power Supply	A/C Cost Due to Power Dissipation	Relative Installation and First Year Cost
\$56,808	\$16,116	\$0	<b>\$72,924</b>
Installation requires 1/0 cable to rack. 8 AWG to tier, 10 AWG to fixture	Cost of remote CC mode precision power supply (iHP) using 48 V configuration	All power dissipation is external to the installation	

### SCENARIO 3: DISTRIBUTED LIGHTING USING LED STRING CONFIGURATION IN 200 V CONFIGURATION

DC Hook-up Wiring	Remote Power Supply	A/C Cost Due to Power Dissipation	Relative Installation and First Year Cost
\$12,108	\$16,116	\$0	<b>\$28,254</b>
Installation requires 6 AWG to rack. 14 AWG to tier, 16 AWG to future	Cost of remote CC mode precision power supply (iHP) using 200 V configuration	All power dissipation is external to the installation	

Notes:

1. A/C cost calculation used:  $\frac{\text{Operating hours} \times \text{BTU per hour}}{1000} \times 0,293 = \text{kWh} \times \text{Electricity costs per kWh}$
2. Hook-up wiring requirements are estimated and costs are relative based on low volume online prices

**Artesyn Embedded Technologies is a global leader in the design and manufacture of highly reliable power conversion solutions for a wide range of industries including communications, computing, consumer electronics, medical, aerospace and industrial automation.**

Artesyn is one of the world's largest and most successful power supply companies, embracing the well-known Astec brand. The company's extensive standard AC-DC product portfolio covers a power range of 3 watts to 24 kilowatts and includes open-frame and enclosed models, highly configurable modular power supplies, rack-mounting bulk front end units, DIN rail power supplies, external power adapters and power supplies for LED lighting. Many of these products are available in medically approved versions and many of the higher power models feature extensive built-in intelligence.

As an industry leader in distributed power applications, Artesyn produces an exceptionally wide range of DC-DC power conversion products. These include isolated DC-DC converters, covering industry-standard sixteenth- to full-brick form factors with power ratings from 6 watts to 800 watts. Artesyn also offers three application-optimized families of non-isolated DC-DC converters, non-isolated memory power, and processor voltage regulator modules (VRMs).

For more than 40 years, customers have trusted Artesyn to help them accelerate time-to-market and shift development efforts to the deployment of new, value-add features and services.

Headquartered in Tempe, Arizona, Artesyn has over 15,000 employees worldwide across multiple engineering centers of excellence, wholly-owned world-class manufacturing facilities, and global sales and support offices.

Artesyn Embedded Technologies, Artesyn and the Artesyn Embedded Technologies logo are trademarks and service marks of Artesyn Embedded Technologies, Inc. All other names and logos referred to are trade names, trademarks, or registered trademarks of their respective owners. Specifications are subject to change without notice. © 2019 Artesyn Embedded Technologies, Inc. All rights reserved. For full legal terms and conditions, please visit <http://www.artesyn.com/legal>.

## WORLDWIDE OFFICES

### Americas

2900 S. Diablo Way  
Tempe, AZ 85282  
USA  
+1 888 412 7832

### Europe (UK)

Ground Floor Offices  
Barberry House, 4 Harbour Bldg  
Waterfront West, West Midlands  
DY5 1LN, UK  
+44 (0) 1384 842 211

### Asia (HK)

14/F, Lu Plaza  
2 Wing Yip Street  
Kwun Tong, Kowloon  
Hong Kong  
+852 2176 3333

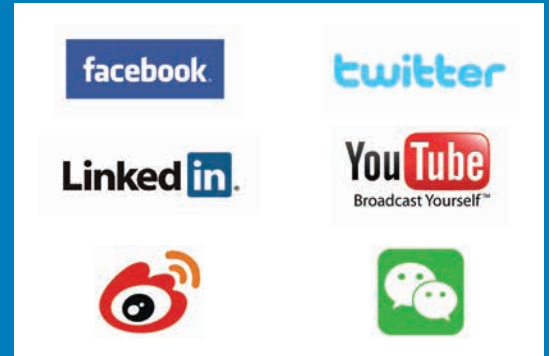

## Stay Connected.

*The latest happenings are being posted on LinkedIn, Twitter, Facebook, Weibo and WeChat! Sign up for one or all of the sites below and stay connected with Artesyn Embedded Technologies!*

[www.linkedin.com/company/artesyn](http://www.linkedin.com/company/artesyn)  
[www.facebook.com/artesynembedded](http://www.facebook.com/artesynembedded)  
[www.twitter.com/artesynembedded](http://www.twitter.com/artesynembedded)  
[www.youtube.com/user/artesynembedded](http://www.youtube.com/user/artesynembedded)  
[www.weibo.com/artesynchina](http://www.weibo.com/artesynchina)

**ARTESYN**<sup>™</sup>  
EMBEDDED TECHNOLOGIES

[www.artesyn.com](http://www.artesyn.com)

For more information: [www.artesyn.com/power](http://www.artesyn.com/power)  
For support: [productsupport.ep@artesyn.com](mailto:productsupport.ep@artesyn.com)

Printed in China  
Horticulture Lighting Brochure 24May2019